



FEATURES

- ▶ Minimum pressure not required
- ▶ Textyle diaphragm for heavy duty applications
- ▶ AISI 316 for high compatibility with aggressive fluids

TECHNICAL SPECIFICATION

- ▶ **Body material:** Stainless Steel AISI 316 series
- ▶ **Armature tube:** Stainless Steel AISI 316 series
- ▶ **Plungers:** Stainless Steel AISI 400 series
- ▶ **Spring:** Stainless Steel AISI 300 series
- ▶ Ex d Housing in Aluminium die cast
- ▶ **Media:** air, inert gas, water, mineral oils, gasoline, diesel
- ▶ **Ambient temperature:** See coils catalogue page for its compatibility
- ▶ **Fluid temperature:** -10°C +90°C with NBR + PA seals
-10°C +140°C with FKM + PA seals
- ▶ **Design pressure PS:** 16 bar
- ▶ **Protection class:** IP65 (complete with electric plug)
- ▶ **Electrical conformity:** IEC 335

AVAILABLE ON REQUEST

- ▶ Explosion proof coil Ex m (see ATEX section)
- ▶ Explosion proof coil Ex d (see ATEX section)
- ▶ Explosion proof coil Ex nA (see ATEX section)
- ▶ Latching coil (see ATEX section)



(Pressure Equipment Directive 97/23/CE) for S.V. 21IH7+21IH8 - IHS 21IN7+21IN8...-IHS

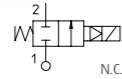

21IH	3	K1	V	150	
Model valve	3= G 3/8 - 3/8 NPT	K1= N.C.	V= FKM		Orefice 10 ⁻¹ mm 150 160 200 250 350 400
	4= G 1/2 - 1/2 NPT				
	5= G 3/4 - 3/4 NPT				
	6= G 1 - 1 NPT				
	7= G1 1/4 - 1 1/4 NPT				
	8= G1 1/2 - 1 1/2 NPT				

B	D	A	08	024	A	S
B= 30mm Ø 13	D EN 175301-803	A= Class F	08= 8W	024= 24V	C= DC	S= Without Approval
U= 36mm Ø 13		V= Class H	12= 12W	110= 110V-120V	A= AC	Y= UL, CSA, VDE
G= 52mm Ø 13			14= 14W	230= 230V-240V	D= AC	

PIPE	Ø (mm)	Kv (l/min)	MAX VISCOSITY cSt (°E)	PRESSURE min	PRESSURE MAX MOPD (bar)						GAS CODE	NPT CODE	DRAWING REFERENCE
					COIL TYPE								
					AC			DC					
B	U	G	B	U	G								
3/8	15	40	12(2)	0	14	-	-	6	-	14	21H3K1V150	21IN3K1V150-IH	1
1/2	16	50	12(2)		14	-	-	6	-	14	21H4K1V160	21IN4K1V160-IH	1
3/4	20	60	12(2)		14	-	-	6	-	14	21H5K1V200	21IN5K1V200-IH	1
1	25	140	12(2)		14	-	-	3	8	14	21H6K1V250	21IN6K1V250-IH	1
1 1/4	35	300	12(2)		-	14	-	-	-	-	21H7K1V350	21IN7K1V250-IH	1
1 1/4	35	300	12(2)		-	-	-	-	7	-	21H7K1V350-S	21IN7K1V250-IHS	1
1 1/2	40	340	12(2)		-	14	-	-	-	-	21H8K1V400	21IN8K1V400-IH	1
1 1/2	40	340	12(2)		-	-	-	-	7	-	21H8K1V400-S	21IN8K1V400-IHS	1

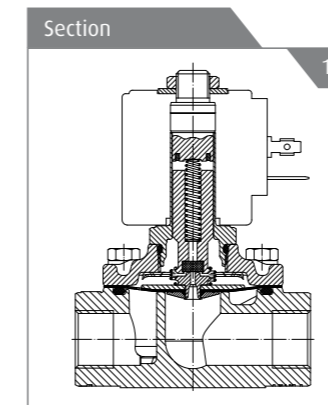

REPAIR KIT
G 3/8 - 3/8 NPT ÷ G 1/2 - 1/2 NPT
KTGIH3K1V15
G 3/4 - 3/4 NPT
KTGIH5K1V20

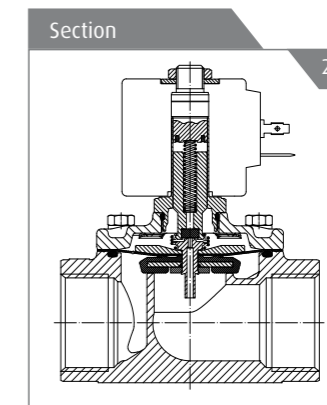

REPAIR KIT
G 1 - 1 NPT
KTGIH6K1V25
G 1 1/4 - 1 1/4 NPT ÷ G 1 1/2 - 1 1/2 NPT
KTGIH7K1V35

RELATED ITEMS

- ▶ P990305: Electrical plug EN 175301-803 Pg9
- ▶ P990306: Electrical plug EN 175301-803 Pg11
- ▶ P992126: Electrical plug EN 175301-803 Pg9 (with OR screw)
- ▶ P992127: Electrical plug EN 175301-803 Pg11 (with OR screw)
- ▶ P992128: Electrical plug EN 175301-803 cable 2 wires, 53cm
- ▶ R452714: Antihumidity kit (up to IP67 protection together with plugs P992126, P992127; P992128 & H coil class)
- ▶ P992087: Timer for automatic switch

INSTALLATION

- ▶ The solenoid valves can be mounted in any position
- ▶ Other port connections available on request
- ▶ Maintenance and instruction sheet available in each solenoid valve box
- ▶ Availability of repair kit and coils as spares

Drawing Reference

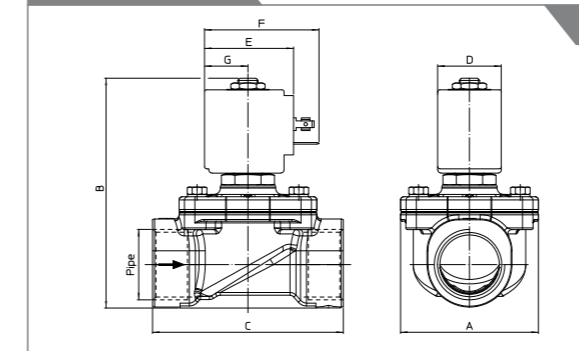

Dimensionale Table

Figure	Coil Type	D mm	E mm	F mm	G mm
1	B	30	42	54	20,5
	U	36	48	60	23,5
	G	52	55	67	25

Dimensionale Table

Figure	Pipe	A mm	B mm	C mm
1	G 3/8 3/8 NPT	58	92	68
	G 1/2 1/2 NPT	58	100	75
	G 3/4 3/4 NPT	65	109	90
	G 1 1 NPT	94	125	128
	G 1/4 1/4 NPT			
	G 1/2 1/2 NPT			

