

# filtro separatore G1"

G1" filter-water-separator



- Sistema di funzionamento: gruppo ciclone ed elemento filtrante  
*Cyclone system and filter element*
- Separazione condensa: 96%  
*Moisture separation: 96%*
- Scarico della condensa semiautomatico o automatico  
*Semi-automatic or automatic moisture exhaust*
- Capacità della tazza: 130 cm<sup>3</sup>  
*Bowl capacity: 130 cm<sup>3</sup>*
- Installazione verticale; staffe di fissaggio a richiesta (cod. STF 6N)  
*Vertical installation; brackets on request (code STF 6N)*
- Tazza metallica  
*Metal bowl*



CODICE DI ORDINAZIONE ORDER CODE		FIL 6N-30-S	FIL 6N-30-A	FIL 6N-05-S
Attacchi <i>Ports</i>		G1"	G1"	G1"
Scarico della condensa <i>Moisture exhaust</i>		semiautomatico <i>semi-automatic</i>	automatico <i>automatic</i>	semiautomatico <i>semi-automatic</i>
Temperatura di esercizio <i>Temperature range</i>		max +50°C	max +50°C	max +50°C
Peso <i>Weight</i>		0.9 kg	0.9 kg	0.9 kg
Pressione di esercizio <i>Working pressure range</i>	$p_{\min}$ $p_{\max}$	0 bar; 0 MPa 17.5 bar; 1.75 MPa	0 bar; 0 MPa 17.5 bar; 1.75 MPa	0 bar; 0 MPa 17.5 bar; 1.75 MPa
Portata massima <i>Maximum flow rate</i>	$p = 6.3 \text{ bar}; \Delta p = 1 \text{ bar}$	$Q_{\max}$ 10000 NI/min	10000 NI/min	10000 NI/min
Elemento filtrante <i>Filter element</i>		30 $\mu\text{m}$	30 $\mu\text{m}$	5 $\mu\text{m}$

Caratteristiche di portata  
*Flow characteristics*

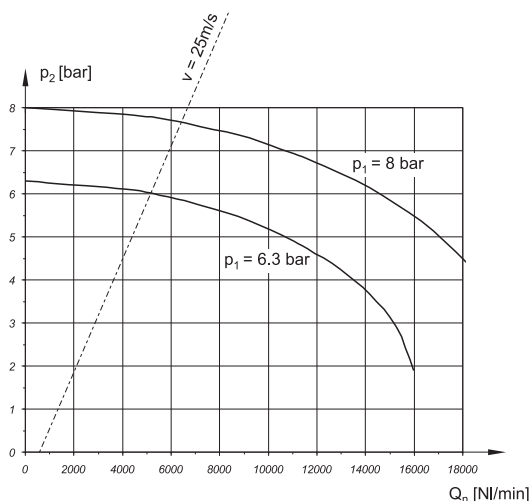

Grado di separazione condensa con  $p_1 = 6.3 \text{ bar}$  costante  
*Moisture separation with  $p_1 = 6.3 \text{ bar}$  constant*

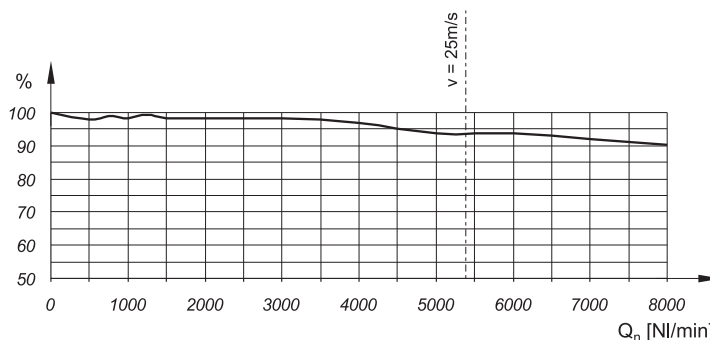

# filtro separatore G1"

G1" filter-water-separator



Le staffe di fissaggio devono essere acquistate separatamente.  
Mounting brackets are bought separately.

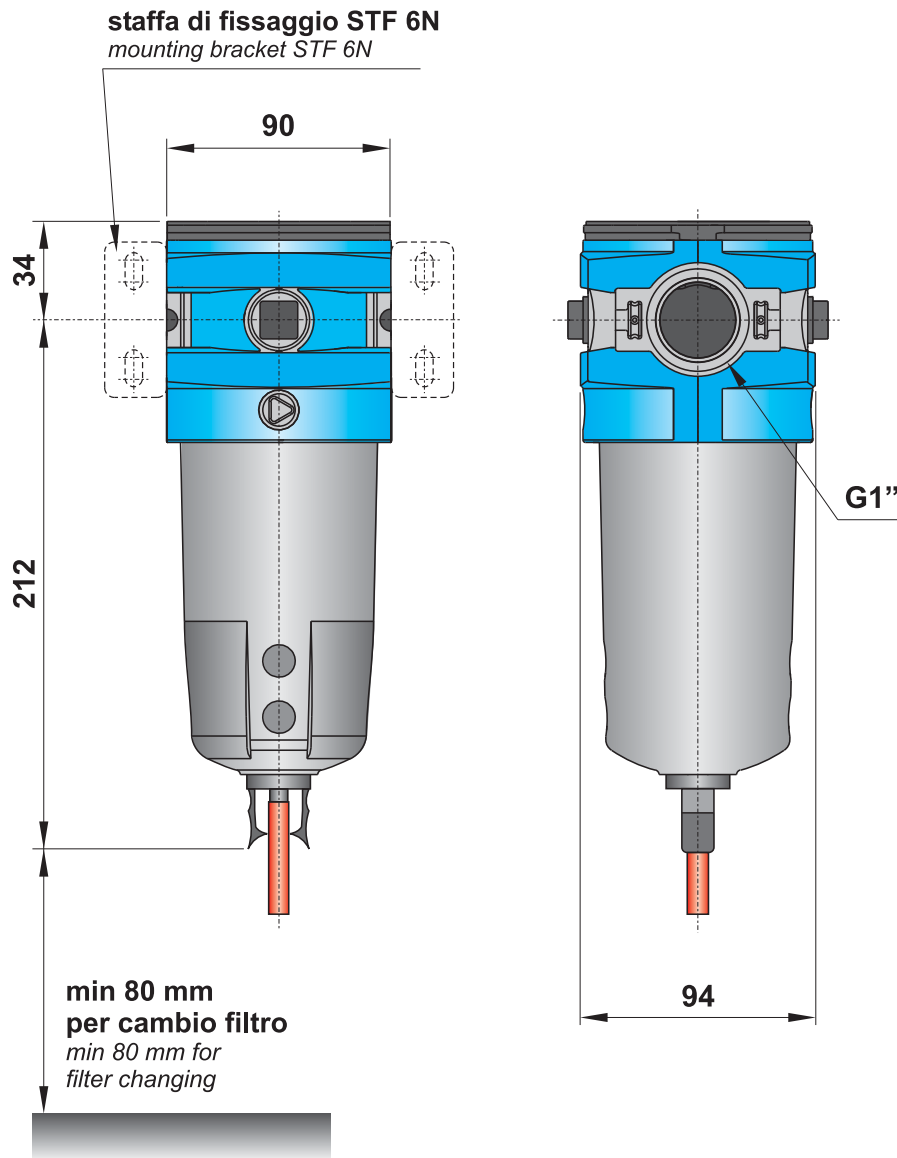
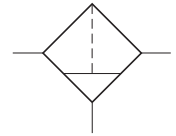

## Materiali

Corpo: alluminio pressofuso

Guarnizioni: NBR

Parti interne: ottone e INOX

Parti esterne: polimeri rinforzati

Tazza: metallica

## Materials

Body: die-cast aluminium

Seals: NBR

Internal parts: brass and stainless steel

External parts: reinforced polymer

Bowl: metal