

valvole di scarico rapido

quick exhaust valves



G1/8"

CODICE DI ORDINAZIONE
ORDER CODE

08.180.4

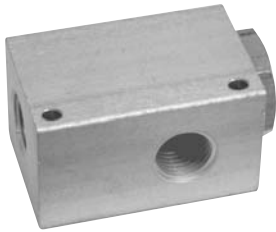
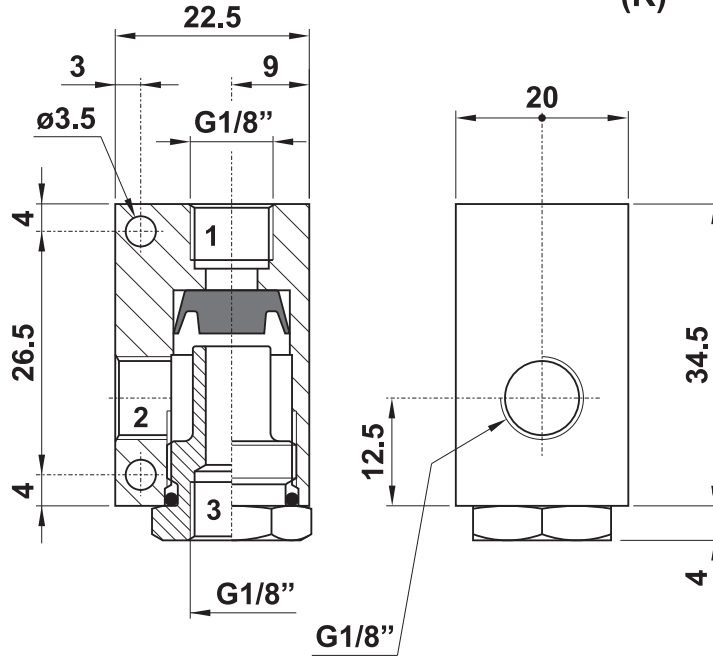
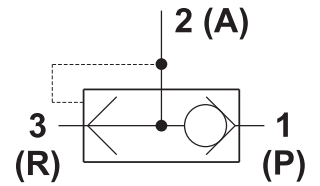

3

G1/4"

CODICE DI ORDINAZIONE
ORDER CODE

08.181.4

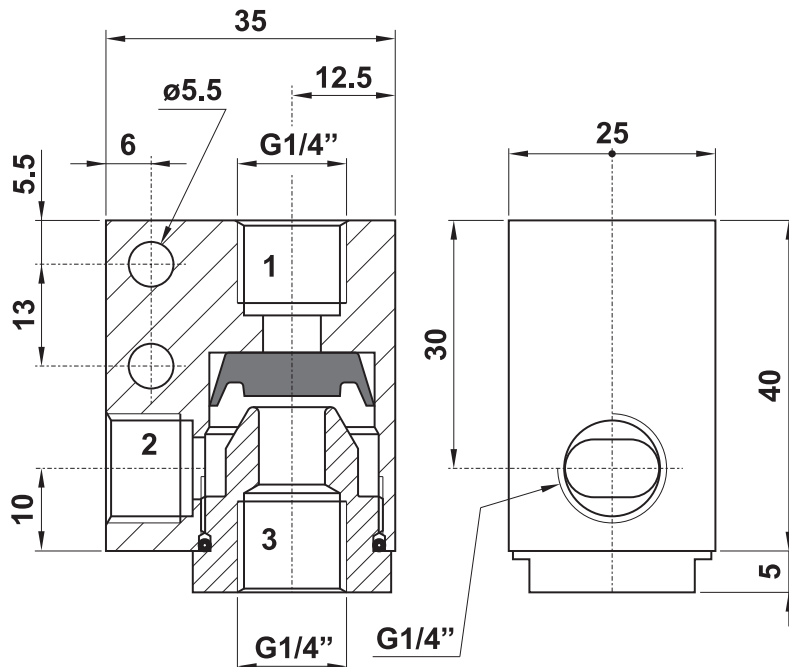

Materiali

Corpo: alluminio 11S

Parti interne: ottone OT58

Guarnizioni: NBR

Materials

Valve body: aluminium 11S

Internal parts: brass OT58

Seals: NBR

Temperatura di esercizio <i>Temperature range</i>	max +60°C
Pressione di esercizio <i>Working pressure</i>	2 ... 10 bar 0.2 ... 1 MPa
Fluido <i>Fluid</i>	Aria filtrata 50µ con o senza lubrificazione 50µ filtered, lubricated or non lubricated air

valvole di scarico rapido

quick exhaust valves

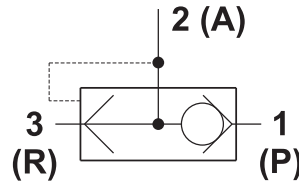
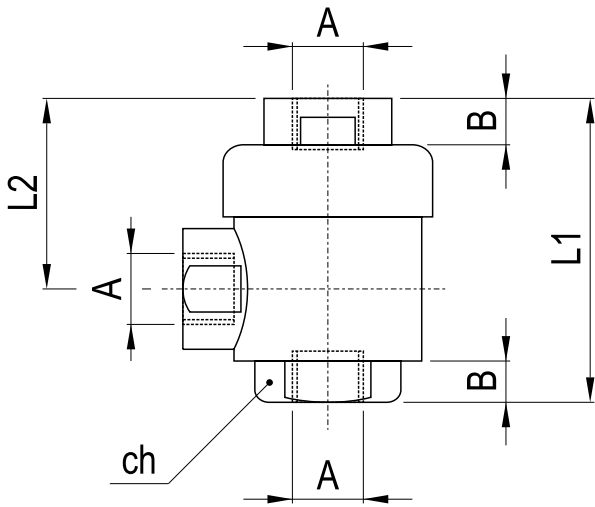

Materiali

Corpo: ottone nichelato

Parti interne: ottone OT58

Guarnizioni: PU (poliuretano)

Materials

Valve body: nickeled brass

Internal parts: brass OT58

Seals: PU (polyurethane)

codice code	A	B	L1	L2	ch
36.626.0	G1/8"	6.5	42	27	15
36.627.0	G1/4"	9.5	53	35	19
36.625.0	G1/2"	13	72	43	26
36.1151.0	G3/4"	18	88	55	32
36.1152.0	G1"	18	94	57.5	38

Attacchi Ports	G1/8"; G1/4"; G1/2"; G3/4"; G1"
Temperatura di esercizio Temperature range	max +60°C
Pressione di esercizio Working pressure	2 ... 10 bar 0.2 ... 1 MPa
Fluido Fluid	Aria filtrata 50µ con o senza lubrificazione 50µ filtered, lubricated or non lubricated air

integrato RFU e valvola scarico rapido

integrated element with RFU and quick exhaust valve



Permette di rallentare la corsa di andata o di ritorno di un cilindro consentendo però la massima velocità nella direzione opposta a quella regolata. È ideale per cilindri a semplice effetto, poiché permette la regolazione dell'alimentazione di aria e lo scarico a piena portata.

It allows to slow down the speed of either the extend or the retract phase of a cylinder. In the opposite phase (not regulated) the cylinder goes at the maximum speed. It is ideal for a single acting cylinder, because it regulates the air supply and allows the exhaust with full flow rate.

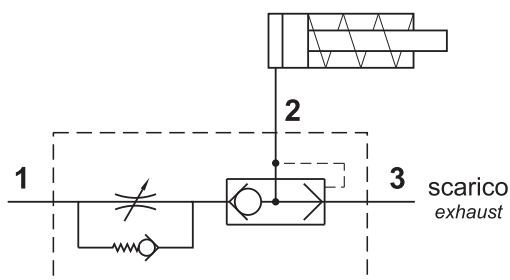

G1/8"

CODICE DI ORDINAZIONE
ORDER CODE

10.015.4

G1/4"

CODICE DI ORDINAZIONE
ORDER CODE

10.016.4

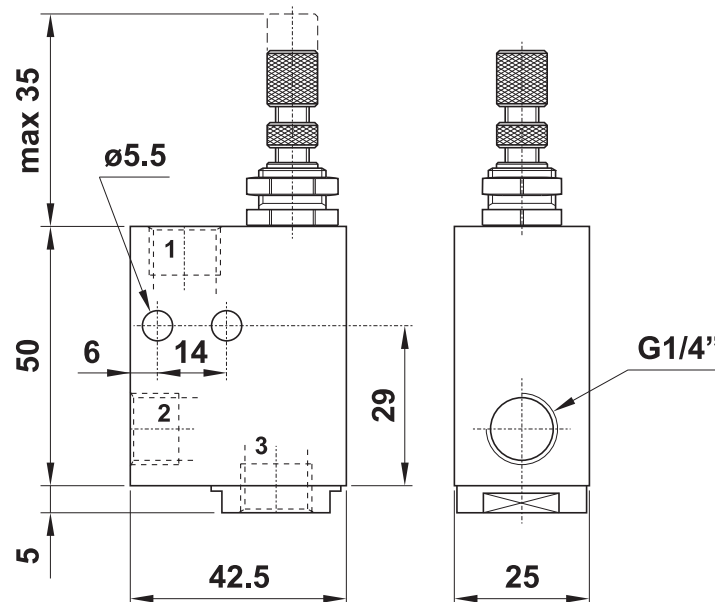
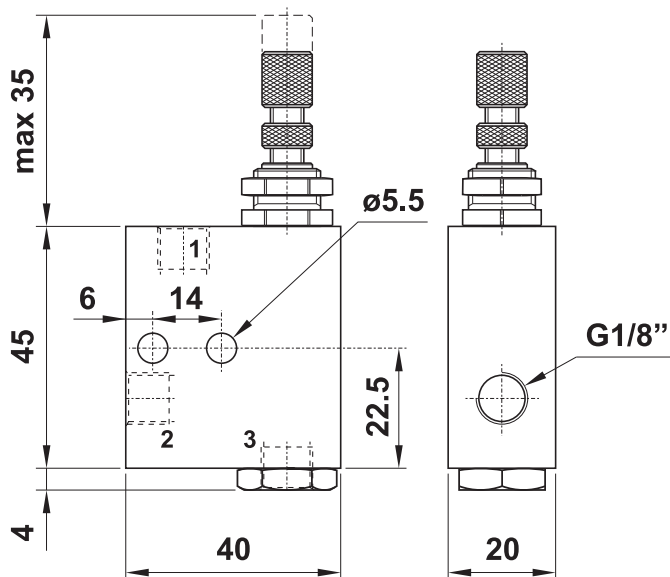

Materiali

Corpo: alluminio 11S

Molle: INOX

Guarnizioni: NBR

Parti interne: ottone OT58

Materials

Body: aluminium 11S

Springs: stainless steel

Seals: NBR

Internal parts: brass OT58

Temperatura di esercizio <i>Temperature range</i>	max +60°C
Pressione di esercizio <i>Working pressure</i>	2 ... 10 bar 0.2 ... 1 MPa
Fluido <i>Fluid</i>	Aria filtrata 50µ con o senza lubrificazione <i>50µ filtered, lubricated or non lubricated air</i>