



**Actuadores Neumáticos Rotativos -ALUMINIO-
Rotary Pneumatic Actuators -ALUMINIUM-**



ACTUADORES NEUMATICOS DE ALUMINIO -INDICE- PNEUMATIC ACTUATORS IN ALUMINIUM -INDEX-

GENERALIDADES ----- N-GP
FEATURES

PAW-PAWS ----- N-PAW
PAW-PAWS

PA00-PA00S ----- N-PA00
PA00-PA00S

PA05-PA05S ----- N-PA05
PA05-PA05S

PA10-PA10S ----- N-PA10
PA10-PA10S

PA15-PA15S ----- N-PA15
PA15-PA15S

PA20-PA20S ----- N-PA20
PA20-PA20S

PA25-PA25S ----- N-PA25
PA25-PA25S

PA30-PA30S ----- N-PA30
PA30-PA30S

GR 201909

P40-P40S ----- N-P40
P40-P40S

PA50-PA50S ----- N-PA50
PA50-PA50S

PA60-PA60S ----- N-PA60
PA60-PA60S

PA70-PA70S ----- N-PA70
PA70-PA70S

ACTUADORES NEUMATICOS (GIRO 180°) PNEUMATIC ACTUATORS (ROTATION 180°)

PAGW-PAGWS ----- N-PAGW
PAGW-PAGWS

PAG00-PAG00S ----- N-PAG00
PAG00-PAG00S

PAG10-PAG10S ----- N-PAG10
PAG10-PAG10S

PAG20-PAG20S ----- N-PAG20
PAG20-PAG20S

PAG30-PAG30S ----- N-PAG30
PAG30-PAG30S

ACTUADORES NEUMATICOS DE ALUMINIO
PNEUMATIC ACTUATORS IN ALUMINIUM

Para automatizar válvulas de bola, mariposa o macho cónico.
To pilot ball, butterfly and plug valves.

- Protegidos contra la corrosión por doble recubrimiento: cataforesis + RILSAN.
- Protected against corrosion by a double coating: epoxy (cataphoresis) & RILSAN.

- Temperatura normal de funcionamiento: -32°C hasta 80°C.
- Normal working temperature: -32°C to 80°C.

- Modelos de simple y doble efecto con pares de 17Nm a 5000Nm a 6 bar.
- Models in spring return and double acting, torques from 17Nm up to 5000Nm at 6 bar.

- Pueden ser accionados con aire, agua o fluido no agresivo hasta 8 bar de presión.
- May be actioned with air, water or nonagressive fluid up to 8 bar pressure.

- Construidos con materiales resistentes a la oxidación y exentos de silicona.
- Manufacturated with materials resistant to oxidation. Silicone free.

- Normas de construcción: ISO-5211, DIN-3337, VDE-3845, NAMUR.
- Norms of construccion: ISO-5211, DIN-3337, VDE-3845, NAMUR.

- Los Actuadores Neumáticos cumplen los requisitos aplicables a la Directiva PED 2014/68/UE y a la Directiva ATEX 2014/34/UE.
- Pneumatic Actuators according to PED Directive 2014/68/EU and ATEX Directive 2014/34/EU.

- Pueden ser equipados con finales de carrera, electroválvulas, posicionadores, y mando manual por volante o reductor desembragable.
- May be equipped with limit switches, solenoid valves, positioners and manual override by wheel or unclutchable gearbox.

- Amplia gama de acoplamientos para adaptar el actuador a la mayoría de válvulas.
- Broad range of couplings to adapt the actuator to the majority of valves.

- De aplicación preferente en Industria Química, Nuclear, Electrónica, Automoción, Alimentaria, Siderurgia, Cemento, Tratamiento de aguas, Gas, ...
- Of preferent application in Chemical Industry, Nuclear, Electronics, Automotion, Food, Steel mills, Water treatment, Gas, ...

MECÀNICA PRISMA, S.L.
C/ Telègraf 1-7
Polígon industrial Sota el Molí
08160 - Montmeló (Barcelona)
SPAIN

Tel: (+34) 93 462 11 54

prisma@prisma.es
www.prisma.es

DESPIECE

DISASSEMBLY



ACTUADOR NEUMÁTICO DE ALUMINIO
ALUMINIUM PNEUMATIC ACTUATOR



PAW: Doble Efecto / Double Acting
PAWS: Simple Efecto / Spring Return

Nº	Descripción Description	Cant. Quant.	Material Material
1	TORNILLO AVELLANADO TAPA CAP COUNTERSUNK SCREW	8	ACERO INOX. AISI-304 AISI-304 STAINLESS STEEL
2	TAPA CAP	2	ALEACIÓN ALUMINIO (2) + (7) ALUMINIUM ALLOY (2) + (7)
3	JUNTA TÓRICA TAPA CAP-O-RING	2	N.B.R. N.B.R.
4	ÉMBOLO PISTON	2	POLIARILAMIDA POLYARILAMIDE
5	CILINDRO CYLINDER	1	ALEACIÓN DE ALUMINIO (2) + (1) ALUMINIUM ALLOY (2) + (1)
6	ARANDELA WASHER	1	POLIACETAL POLYACETAL
7	ANILLO DE SEGURIDAD SPRING CLIP	1	ACERO INOXIDABLE STAINLESS STEEL
8	INDICADOR VISUAL POSITION INDICATOR	1	POLIACETAL POLYACETAL
9	JUNTA TÓRICA PLACA PLATE O-RING	2	N.B.R. N.B.R.
10	ANILLO GUÍA GUIDE RING	2	POLIACETAL + Mb POLYACETAL + Mb
11	JUNTA TÓRICA ÉMBOLO PISTON O-RING	2	N.B.R. N.B.R.
12	JUNTA TÓRICA EJE SHAFT O-RING	2	N.B.R. N.B.R.
13	JUNTA TÓRICA EJE SHAFT O-RING	2	N.B.R. N.B.R.
14	MUELLES PRECARGADOS PRELOADED SPRINGS	12	DIN-17223-C (6) (4) DIN-17223-C (6) (4)
15	PLACA BASE (ISO-5211) BASE PLATE (ISO-5211)	1	POLIAMIDA + FV POLYAMIDE + FG
16	EJE SHAFT	1	POLIAMIDA + FV POLYAMIDE + FG
17	DADO DE CONEXIÓN DRIVE ADAPTER	1	ACERO INOXIDABLE AISI-316 AISI-316 STAINLESS STEEL
18	TORNILLO ALLEN ALLEN SCREW	2	ACERO INOXIDABLE AISI-304 AISI-304 STAINLESS STEEL
19	TUERCA NUT	4	ACERO INOXIDABLE AISI-304 AISI-304 STAINLESS STEEL
20	TUERCA NUT	4	ACERO INOXIDABLE AISI-304 AISI-304 STAINLESS STEEL
21	PLACA CONEXIÓN NEUMÁTICA PNEUMATIC CONNECTION PLATE	1	POLIAMIDA + FV POLYAMIDE + FG
22	TORNILLO ALLEN ALLEN SCREW	2	ACERO INOXIDABLE AISI-304 AISI-304 STAINLESS STEEL

- (1) RECUBRIMIENTO CON POLIAMIDA.
COVERED WITH POLYAMIDE.
- (2) RECUBRIMIENTO POR CATAFORESIS.
COVERED BY CATAPHORESIS.
- (4) CANTIDAD VARIABLE, CONSULTAR
TABLAS PARES SIMPLE EFECTO.
VARIABLE QUANTITY, PLEASE SEE THE
SPRING RETURN TORQUE CHART.
- (6) PASIVADO DE CROMO TRIVALENTE.
TRIVALENT CHROMINIUM PASSIVATION.
- (7) RECUBR. CON POLIURETANO.
COVERED WITH POLYURETHANE.

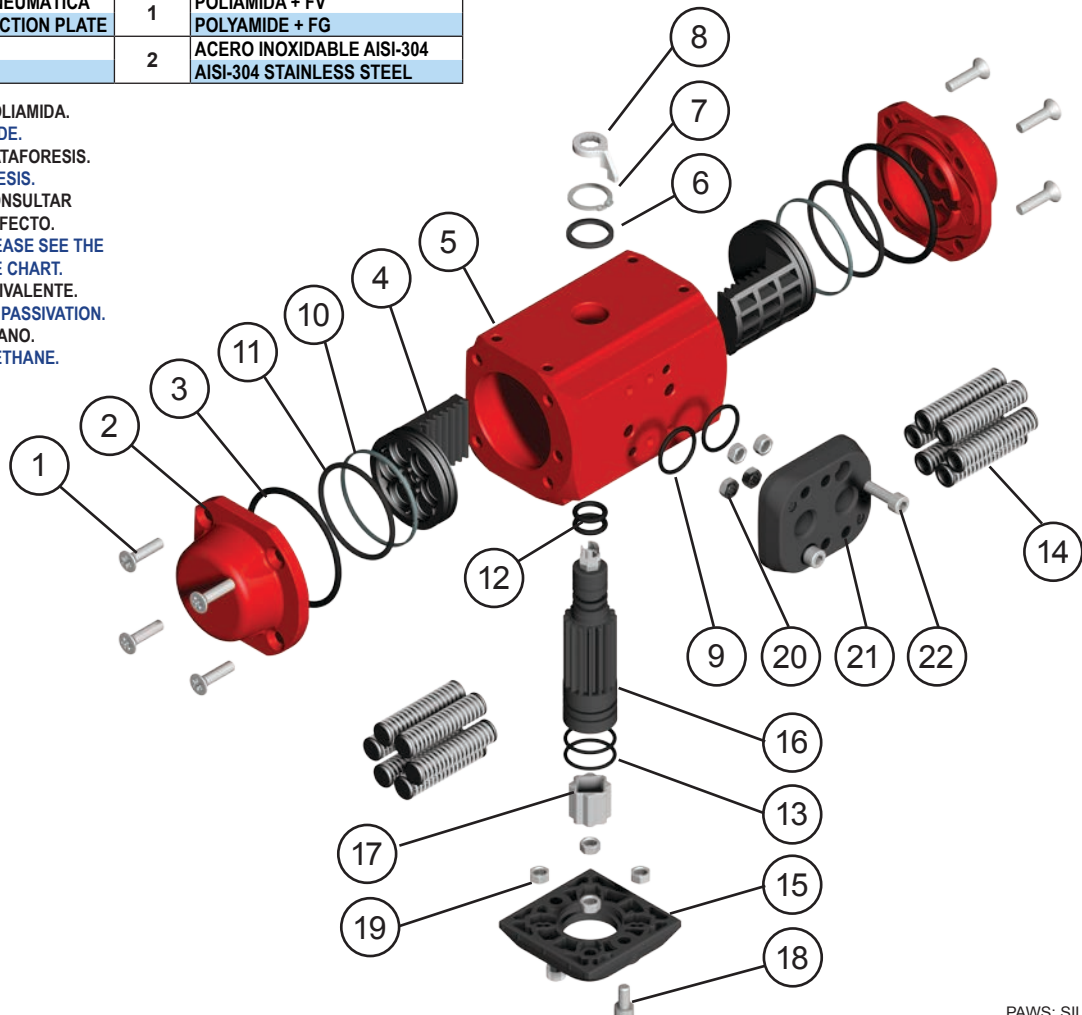

* PAW: SIL3
PAWS: SIL2 / SIL3 (SC)

MODELOS MODELS	TIEMPO DE MANIOBRA EN SEG. CYCLE TIME IN SECS.		PESOS WEIGHTS		CAPACIDAD EN LITROS CAPACITY IN LITRES	
	PARA ABRIR TO OPEN	PARA CERRAR TO CLOSE	Kg.	Lb.	PARA ABRIR TO OPEN	PARA CERRAR TO CLOSE
PAW	0,1	0,1	0,92	2,02	0,075	0,11
PAWS	0,15	0,15	1	2,20	0,075	

Tiempo de maniobra sin par resistente a 6 bar.
Cycle time w/o resistant torque at 6 bar.

Dimensiones en mm.
Dimensions in mm.

Para calcular el consumo, multiplicar las cifras del cuadro por la presión real de trabajo.

To calculate the consumption, multiply the above figures by the real working pressure.

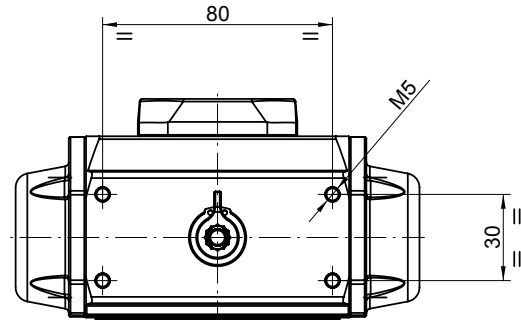
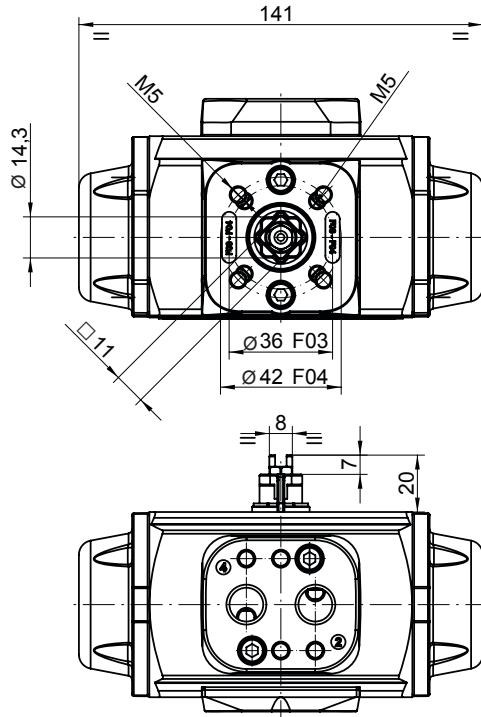

PAWS DOBLE EFECTO DOUBLE ACTING TORQUES

PAW	PRESION AIRE AIR PRESSURE							
bar	3	4	4,5	5	5,5	6	7	8
p.s.i	43,5	58	65,3	72,5	79,8	87	101,5	116
Nm	7,9	11,3	12,7	14,1	15,5	17	19,8	22,9
Lb.in	69,3	100	112,4	124,8	137,2	150,5	175,2	202,7

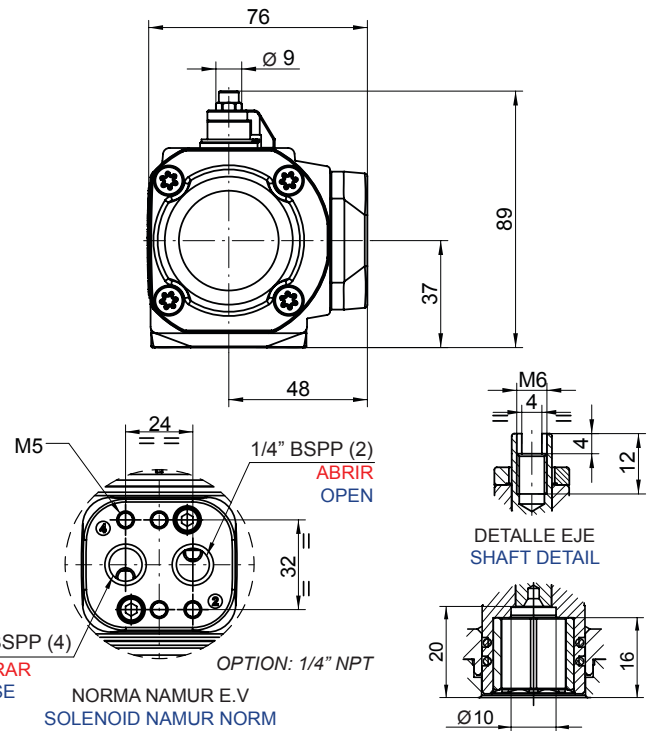

PAWS SIMPLE EFECTO SPRING RETURN TORQUES

PAWS	PAR MUELLES SPRING TORQUES		PAR A LA PRESIÓN INDICADA AIR TORQUE AT INDICATED PRESSURE																
	INICIAL INITIAL	FINAL END	3		4		4,5		5		5,5		6		7		8		bar
N			43,5	58	65,3	72,5	79,8	87	101,5	116									p.s.i
6*	10	6,7					6	2,7	7,4	4,1	8,8	5,5	10,3	7	13,1	9,8	16,2	12,9	Nm
	88,5	59,3					53,1	23,9	65,5	36,3	77,9	48,7	91,2	62	115,9	86,7	143,4	114,2	Lb.in
5	8,5	5,8			5,5	2,8	6,9	4,2	8,3	5,6	9,7	7	11,2	8,5	14	11,3	17,1	14,4	Nm
	75,2	51,3			48,7	24,8	61,1	37,2	73,5	49,6	85,9	62	99,1	75,2	123,9	100	151,3	127,5	Lb.in
4	7	4,6	3,3	0,9	6,7	4,3	8,1	5,7	9,5	7,1	10,9	8,5	12,4	10	15,2	12,8	18,3	15,9	Nm
	62	40,7	29,2	8	59,3	38,1	71,7	50,4	84,1	62,8	96,5	75,2	109,7	88,5	134,5	113,3	162	140,7	Lb.in
3	5,5	3,6	4,3	2,4	7,7	5,8	9,1	7,2	10,5	8,6	11,9	10	13,4	11,5	16,2	14,3			Nm
	48,7	31,9	38,1	21,2	68,2	51,3	80,5	63,7	92,9	76,1	105,3	88,5	118,6	101,8	143,4	126,6			Lb.in
2	4	2,4	5,5	3,9	8,9	7,3	10,3	8,7	11,7	10,1	13,1	11,5	14,6	13					Nm
	35,4	21,2	48,7	34,5	78,8	64,6	91,2	77	103,6	89,4	115,9	101,8	129,2	115,1					Lb.in

N: Número de muelles por banda
Number of springs per side

* Número de muelles estándar
* Standard number of springs

DESPIECE

DISASSEMBLY

Nº	Descripción Description	Cant. Quant.	Material Material
1	TORNILLO AVELLANADO TAPA CAP COUNTERSUNK SCREW	8	ACERO INOXIDABLE AISI-304 AISI-304 STAINLESS STEEL
2	TAPA CAP	2	ALEACIÓN ALUMINIO (2) + (7) ALUMINIUM ALLOY (2) + (7)
3	JUNTA TÓRICA TAPA CAP-O-RING	2	N.B.R. N.B.R.
4	EMBOLO PISTON	2	ALEACIÓN ALUMINIO (2) ALUMINIUM ALLOY (2)
5	CILINDRO CYLINDER	1	ALEACIÓN DE ALUMINIO (2) + (1) ALUMINIUM ALLOY (2) + (1)
6	ARANDELA WASHER	1	POLIACETAL POLYACETAL
7	ANILLO DE SEGURIDAD SPRING CLIP	1	ACERO INOXIDABLE STAINLESS STEEL
8	INDICADOR VISUAL POSITION INDICATOR	1	POLIAMIDA POLYAMIDE
9	GUIA EMBOLO PISTON GUIDE	2	POLIACETAL + Mb POLYACETAL + Mb
10	ANILLO GUIA GUIDE RING	2	POLIACETAL + Mb POLYACETAL + Mb
11	JUNTA TÓRICA EMBOLO PISTON O-RING	2	N.B.R. N.B.R.
12	JUNTA TÓRICA EJE SHAFT O-RING	2	N.B.R. N.B.R.
13	JUNTA TÓRICA EJE SHAFT O-RING	2	N.B.R. N.B.R.
14	MUELLES PRECARGADOS PRELOADED SPRINGS	12	DIN-17223-C (6) (4) DIN-17223-C (6) (4)
15	PLACA BASE (ISO-5211) BASE PLATE (ISO-5211)	1	POLIAMIDA + FV POLYAMIDE + FG
16	EJE SHAFT	1	ACERO (2) STEEL (2)
17	LEVA CAM	1	ACERO (2) STEEL (2)
18	TORNILLO ALLEN ALLEN SCREW	2	ACERO INOXIDABLE AISI-304 AISI-304 STAINLESS STEEL
19	TUERCA NUT	4	ACERO INOXIDABLE AISI-304 AISI-304 STAINLESS STEEL
20	JUNTA TÓRICA PLACA PLATE O-RING	2	N.B.R. N.B.R.
21	TUERCA NUT	4	ACERO INOXIDABLE AISI-304 AISI-304 STAINLESS STEEL
22	PLACA CONEXIÓN NEUMÁTICA PNEUMATIC CONNECTION PLATE	1	POLIAMIDA + FV POLYAMIDE + FG
23	TORNILLO ALLEN PLACA PLATE ALLEN SCREW	2	ACERO INOXIDABLE AISI-304 AISI-304 STAINLESS STEEL
24	TORNILLO HEXAGONAL HEXAGONAL SCREW	2	ACERO INOXIDABLE AISI-304 AISI-304 STAINLESS STEEL
25	TUERCA NUT	2	ACERO INOXIDABLE AISI-304 AISI-304 STAINLESS STEEL
26	ARANDELA BUSHING	2	ACERO INOXIDABLE AISI-304 AISI-304 STAINLESS STEEL
27	JUNTA TÓRICA O-RING	2	N.B.R. N.B.R.



ACTUADOR NEUMÁTICO DE ALUMINIO
ALUMINIUM PNEUMATIC ACTUATOR



PA00: Doble Efecto / Double Acting

PA00S: Simple Efecto / Spring Return

- (1) RECUBRIMIENTO CON POLIAMIDA.
COVERED WITH POLYAMIDE.
- (2) RECUBRIMIENTO POR CATAFORESIS.
COVERED BY CATAPHORESIS.
- (4) CANTIDAD VARIABLE, CONSULTAR
TABLAS PARES SIMPLE EFECTO.
VARIABLE QUANTITY, PLEASE SEE THE
SPRING RETURN TORQUE CHART.
- (6) PASIVADO DE CROMO TRIVALENTE.
TRIVALENT CHROMIUM PASSIVATION.
- (7) RECUBRIMIENTO CON POLIURETANO.
COVERED WITH POLYURETHANE.

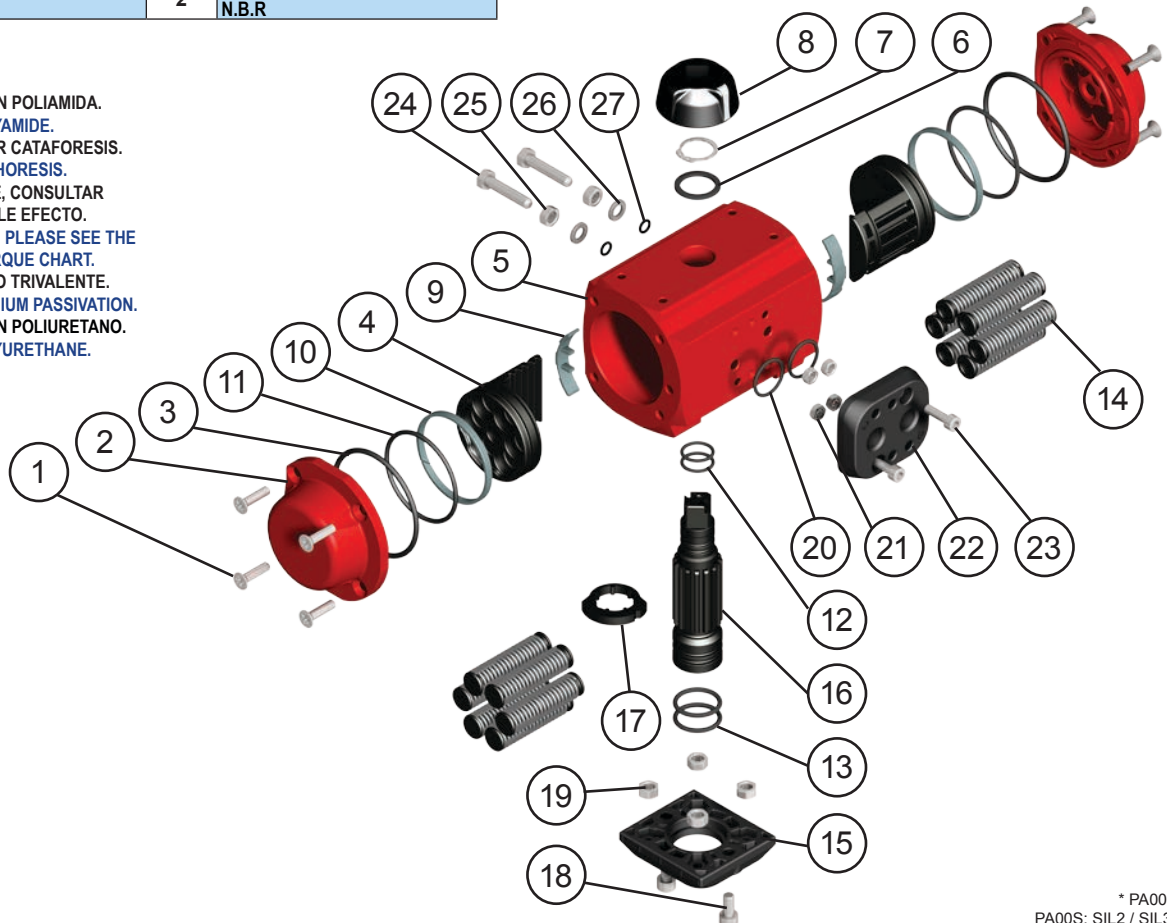

* PA00: SIL3
PA00S: SIL2 / SIL3 (SC)

MODELOS MODELS	TIEMPO DE MANIOBRA EN SEG. CYCLE TIME IN SECS.		PESOS WEIGHTS		CAPACIDAD EN LITROS CAPACITY IN LITRES	
	PARA ABRIR TO OPEN	PARA CERRAR TO CLOSE	Kg.	Lb.	PARA ABRIR TO OPEN	PARA CERRAR TO CLOSE
PA00	0,15	0,15	1,40	3,09	0,15	0,18
PA00S	0,2	0,2	1,625	3,58	0,15	

Tiempo de maniobra sin par resistente a 6 bar.
Cycle time w/o resistant torque at 6 bar.

Dimensiones en mm.
Dimensions in mm.

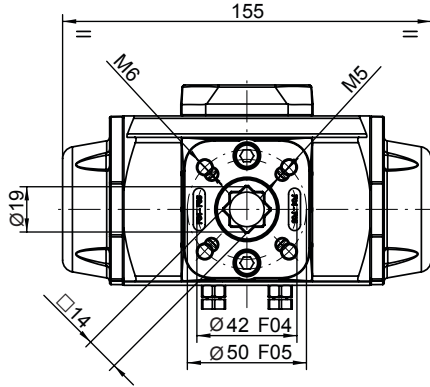

Para calcular el consumo, multiplicar las cifras del cuadro por la presión real de trabajo.

To calculate the consumption, multiply the above figures by the real working pressure.

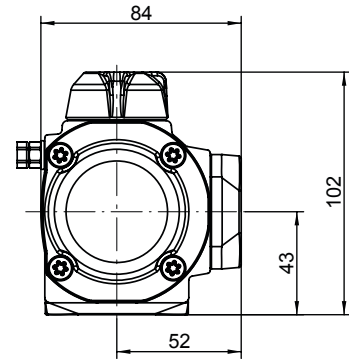
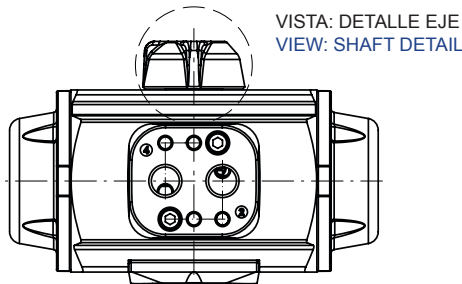
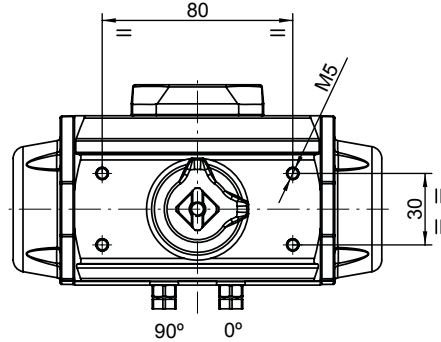

PA00 PARES DOBLE EFECTO DOUBLE ACTING TORQUES

PA00	PRESION AIRE AIR PRESSURE							
bar	3	4	4,5	5	5,5	6	7	8
p.s.i	43,5	58	65,3	72,5	79,8	87	101,5	116
Nm	13,3	18,3	20,9	23,4	26	28,5	33,6	38,7
Lb.in	117,7	162	184,6	207,1	230,1	252,2	297,4	342,5

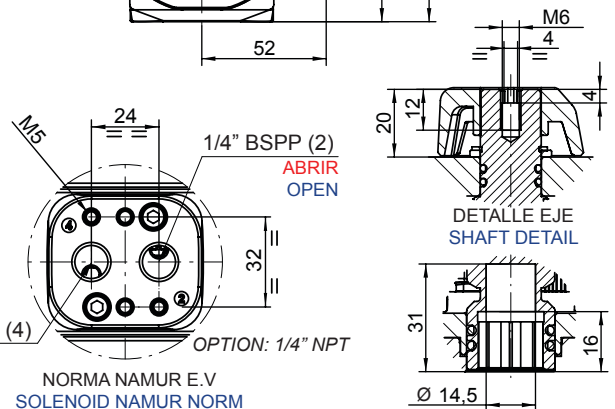

PA00S PARES SIMPLE EFECTO SPRING RETURN TORQUES

PA00S	PAR MUELLES SPRING TORQUES		PAR A LA PRESIÓN INDICADA AIR TORQUE AT INDICATED PRESSURE																bar
			3		4		4,5		5		5,5		6		7		8		
N	INICIAL INITIAL	FINAL END	INICIAL INITIAL	FINAL END	INICIAL INITIAL	FINAL END	INICIAL INITIAL	FINAL END	INICIAL INITIAL	FINAL END	INICIAL INITIAL	FINAL END	INICIAL INITIAL	FINAL END	INICIAL INITIAL	FINAL END	INICIAL INITIAL	FINAL END	p.s.i
6*	18,8	12,7					8,2	2,1	10,7	4,6	13,3	7,2	15,8	9,7	20,9	14,8	26	19,9	Nm
	166,4	112,4					72,2	18,2	94,7	40,7	117,7	63,7	139,8	85,8	185,0	131,0	230,1	176,1	Lb.in
5	15,8	10,7			7,6	2,5	10,2	5,1	12,7	7,6	15,3	10,2	17,8	12,7	22,9	17,8	28	22,9	Nm
	139,8	94,7			67,3	22,1	89,9	44,8	112,4	67,3	135,4	90,3	157,5	112,4	202,7	157,5	247,8	202,7	Lb.in
4	12,6	8,7			9,6	5,7	12,2	8,3	14,7	10,8	17,3	13,4	19,8	15,9	24,9	21	30	26,1	Nm
	111,5	77			85,0	50,4	107,6	73,1	130,1	95,6	153,1	118,6	175,2	140,7	220,4	185,9	265,5	231,0	Lb.in
3	9,7	6,6	6,7	3,6	11,7	8,6	14,3	11,2	16,8	13,7	19,4	16,3	21,9	18,8	27	23,9	32,1	29	Nm
	85,8	58,4	59,3	31,9	103,5	76,1	126,2	98,8	148,7	121,2	171,7	144,3	193,8	166,4	239	211,5	284,1	256,7	Lb.in
2	6,6	4,1	9,2	6,7	14,2	11,7	16,8	14,3	19,3	16,8	21,9	19,4	24,4	21,9	29,5	27	34,6	32,1	Nm
	58,4	36,3	81,4	59,3	125,7	103,5	148,3	126,2	170,8	148,7	193,8	171,7	215,9	193,8	261,1	239	306,2	284,1	Lb.in

N: Número de muelles por banda y posición
Number of springs per side and position

* Número de muelles estándar
* Standard number of springs

DESPIECE

DISASSEMBLY



ACTUADOR NEUMÁTICO DE ALUMINIO
ALUMINIUM PNEUMATIC ACTUATOR



PA05: Doble Efecto / Double Acting

PA05S: Simple Efecto / Spring Return

Nº	Descripción Description	Cant. Quant.	Material Material
1	TORNILLO AVELLANADO TAPA CAP COUNTERSUNK SCREW	8	ACERO INOXIDABLE AISI-304 AISI-304 STAINLESS STEEL
2	TAPA CAP	2	ALEACIÓN ALUMINIO (2) + (7) ALUMINIUM ALLOY (2) + (7)
3	JUNTA TÓRICA TAPA CAP-O-RING	2	N.B.R. N.B.R.
4	ÉMBOLO PISTON	2	ALEACIÓN ALUMINIO (2) ALUMINIUM ALLOY (2)
5	CILINDRO CYLINDER	1	ALEACIÓN DE ALUMINIO (2) + (1) ALUMINIUM ALLOY (2) + (1)
6	ARANDELA WASHER	1	POLIACETAL POLYACETAL
7	ANILLO DE SEGURIDAD SPRING CLIP	1	ACERO INOXIDABLE STAINLESS STEEL
8	INDICADOR VISUAL POSITION INDICATOR	1	POLIAMIDA POLYAMIDE
9	GUÍA ÉMBOLO PISTON GUIDE	2	POLIACETAL + Mb POLYACETAL + Mb
10	ANILLO GUÍA GUIDE RING	2	POLIACETAL + Mb POLYACETAL + Mb
11	JUNTA TÓRICA ÉMBOLO PISTON O-RING	2	N.B.R. N.B.R.
12	JUNTA TÓRICA EJE SHAFT O-RING	2	N.B.R. N.B.R.
13	JUNTA TÓRICA EJE SHAFT O-RING	2	N.B.R. N.B.R.
14	MUELLES PRECARGADOS PRELOADED SPRINGS	12	DIN-17223-C (6) (4) DIN-17223-C (6) (4)
15	LEVA CAM	1	ACERO (2) STEEL (2)
16	EJE SHAFT	1	ACERO (2) STEEL (2)
17	JUNTA TÓRICA PLACA PLATE O-RING	2	N.B.R. N.B.R.
18	TUERCA NUT	4	ACERO INOXIDABLE AISI-304 AISI-304 STAINLESS STEEL
19	PLACA CONEXIÓN NEUMÁTICA PNEUMATIC CONNECTION PLATE	1	POLIAMIDA + FV POLYAMIDE + FG
20	TORNILLO ALLEN PLACA PLATE ALLEN SCREW	2	ACERO INOXIDABLE AISI-304 AISI-304 STAINLESS STEEL
21	TORNILLO HEXAGONAL HEXAGONAL SCREW	2	ACERO INOXIDABLE AISI-304 AISI-304 STAINLESS STEEL
22	TUERCA NUT	2	ACERO INOXIDABLE AISI-304 AISI-304 STAINLESS STEEL
23	ARANDELA BUSHING	2	ACERO INOXIDABLE AISI-316 AISI-316 STAINLESS STEEL
24	JUNTA TÓRICA O-RING	2	N.B.R. N.B.R.

- (1) RECUBRIMIENTO CON POLIAMIDA.
COVERED WITH POLYAMIDE.
- (2) RECUBRIMIENTO POR CATAFORESIS.
COVERED BY CATAPHORESIS.
- (4) CANTIDAD VARIABLE, CONSULTAR
TABLAS PARES SIMPLE EFECTO.
VARIABLE QUANTITY, PLEASE SEE THE
SPRING RETURN TORQUE CHART.
- (6) PASIVADO DE CROMO TRIVALENTE.
TRIVALENT CHROMINIUM PASSIVATION.
- (7) RECUBRIMIENTO CON POLIURETANO.
COVERED WITH POLYURETHANE.

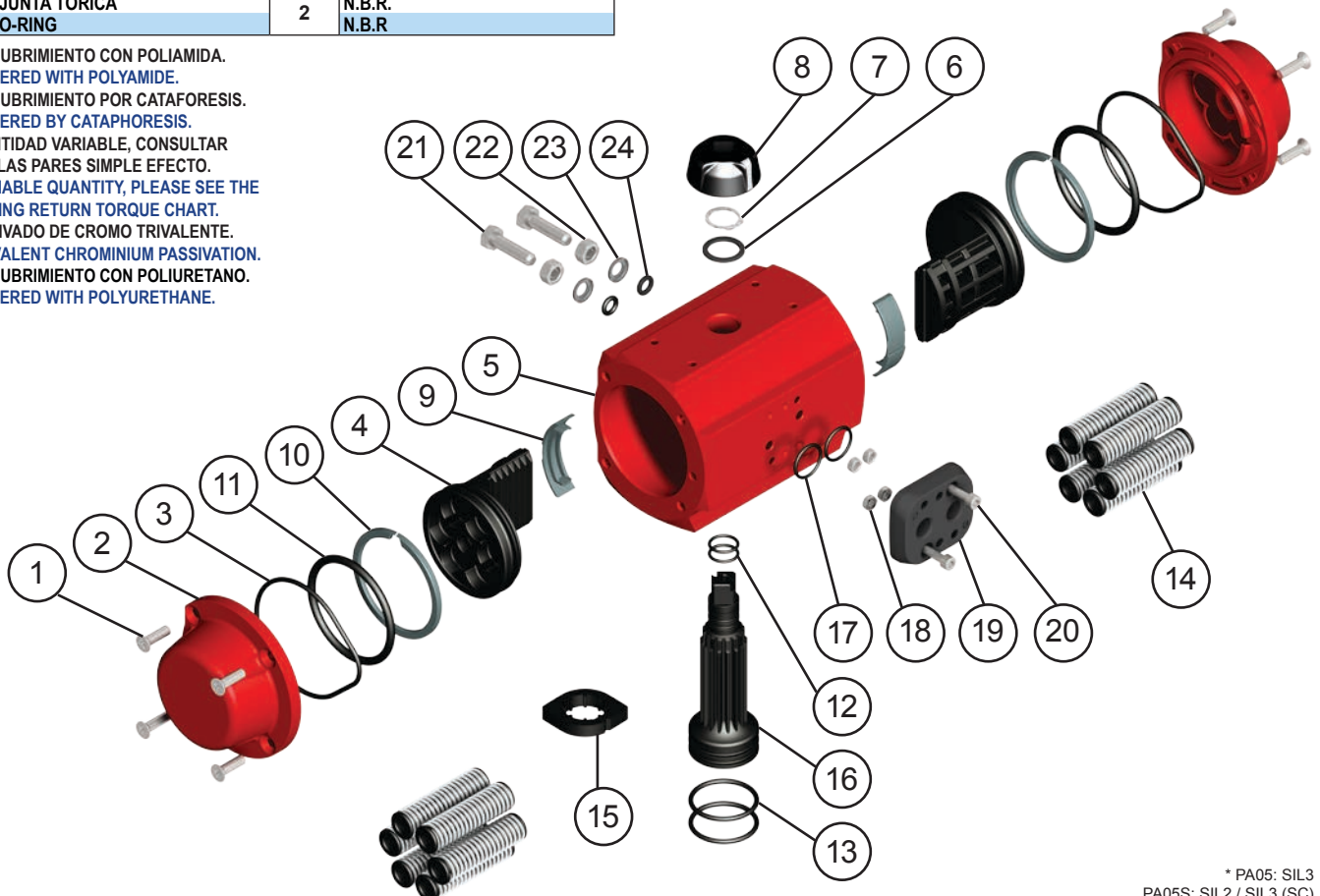

* PA05: SIL3
PA05S: SIL2 / SIL3 (SC)

MODELOS MODELS	TIEMPO DE MANIOBRA EN SEG. CYCLE TIME IN SECS.		PESOS WEIGHTS		CAPACIDAD EN LITROS CAPACITY IN LITRES	
	PARA ABRIR TO OPEN	PARA CERRAR TO CLOSE	Kg.	Lb.	PARA ABRIR TO OPEN	PARA CERRAR TO CLOSE
PA05	0,2	0,2	2,57	5,67	0,28	0,37
PA05S	0,25	0,25	2,94	6,49	0,28	

Tiempo de maniobra sin par resistente a 6 bar.
Cycle time w/o resistant torque at 6 bar.

Dimensiones en mm.
Dimensions in mm.

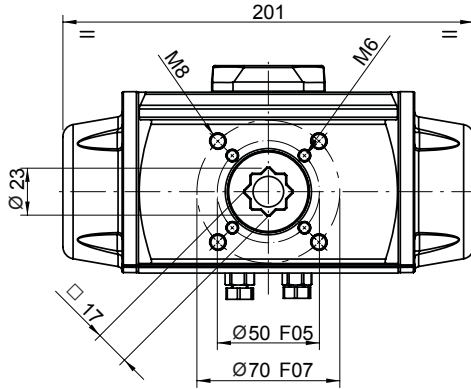

Para calcular el consumo, multiplicar las cifras del cuadro por la presión real de trabajo.

To calculate the consumption, multiply the above figures by the real working pressure.

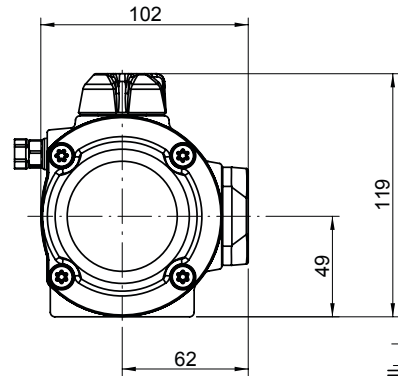
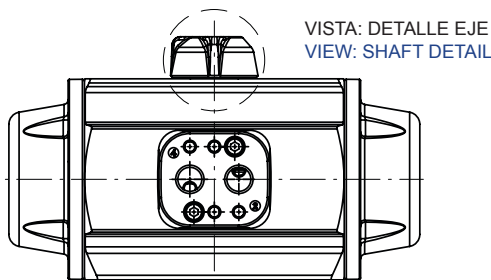
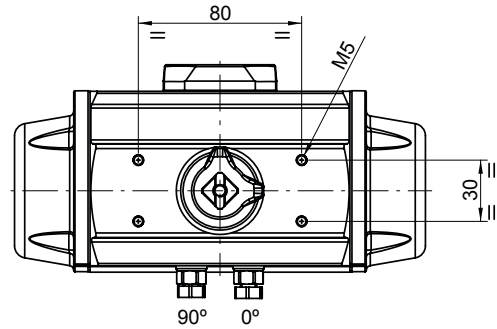

PARES DOBLE EFECTO DOUBLE ACTING TORQUES

PA05	PRESION AIRE AIR PRESSURE							
bar	3	4	4,5	5	5,5	6	7	8
p.s.i	43,5	58	65,3	72,5	79,8	87	101,5	116
Nm	23,5	32,3	36,7	41	45,3	49,7	58,4	67,1
Lb.in	208	286	324,5	363	401	440	517	594

PARES SIMPLE EFECTO SPRING RETURN TORQUES

PA05S	PAR MUELLES SPRING TORQUES		PAR A LA PRESIÓN INDICADA AIR TORQUE AT INDICATED PRESSURE																	
			3		4		4,5		5		5,5		6		7		8		bar	
N	INICIAL INITIAL	FINAL END	43,5	58	65,3	72,5	79,8	87	101,5	116										
6*	31,4 277,9	20,9 185						15,8 139,5	5,3 46,6	20,1 177,9	9,6 85	24,4 216	13,9 123	28,8 254,9	18,3 162	37,5 331,9	27 239	46,2 408,9	35,7 316	Nm Lb.in
5	27 239	17,4 154			14,9 131,9	5,3 46,9	19,3 170,5	9,7 85,5	23,6 208,9	14 123,9	27,9 246,9	18,3 162	32,3 285,9	22,7 200,9	41 362,9	31,4 277,5	49,7 439,9	40,1 354,9		Nm Lb.in
4	21,8 192,9	13,9 123	9,6 85	1,7 15	18,4 162,9	10,5 92,9	22,8 201,5	14,9 131,6	27,1 239,9	19,2 169,9	31,4 277,9	23,5 208	35,8 316,9	27,9 246,9	44,5 393,9	36,6 323,9	53,2 470,9	45,3 400,9		Nm Lb.in
3	18,3 162	11,3 100	12,2 108	5,2 46	21 185,9	14 123,9	25,4 224,5	18,4 162,5	29,7 262,9	22,7 200,9	34 300,9	27 239	38,4 339,9	31,4 277,9	47,1 416,9	40,1 354,9				Nm Lb.in
2	12,2 108	7,8 69	15,7 139	11,3 100	24,5 216,8	20,1 177,9	28,9 255,5	24,5 216,5	33,2 293,8	28,8 254,9	37,5 331,9	33,1 293	41,9 370,8	37,5 331,9						Nm Lb.in

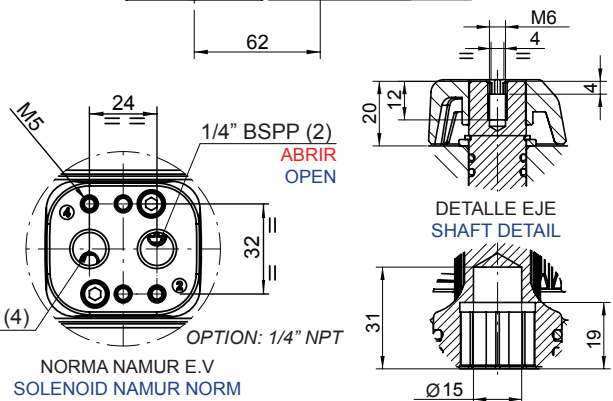

N: Número de muelles por banda y posición
Number of springs per side and position

* Número de muelles estándar
* Standard number of springs

DESPIECE

DISASSEMBLY



ACTUADOR NEUMÁTICO DE ALUMINIO
ALUMINIUM PNEUMATIC ACTUATOR



PA10: Doble Efecto / Double Acting

PA10S: Simple Efecto / Spring Return

Nº	Descripción Description	Cant. Quant.	Material Material
1	TORNILLO AVELLANADO TAPA CAP COUNTERSUNK SCREW	8	ACERO INOXIDABLE AISI-304 AISI-304 STAINLESS STEEL
2	TAPA CAP	2	ALEACIÓN ALUMINIO (2) + (7) ALUMINIUM ALLOY (2) + (7)
3	JUNTA TÓRICA TAPA CAP-O-RING	2	N.B.R. N.B.R.
4	ÉMBOLO PISTON	2	ALEACIÓN ALUMINIO (2) ALUMINIUM ALLOY (2)
5	CILINDRO CYLINDER	1	ALEACIÓN DE ALUMINIO (2) + (1) ALUMINIUM ALLOY (2) + (1)
6	ARANDELA WASHER	1	POLIACETAL POLYACETAL
7	ANILLO DE SEGURIDAD SPRING CLIP	1	ACERO INOXIDABLE STAINLESS STEEL
8	INDICADOR VISUAL POSITION INDICATOR	1	POLIAMIDA POLYAMIDE
9	GUÍA ÉMBOLO PISTON GUIDE	2	POLIACETAL + Mb POLYACETAL + Mb
10	ANILLO GUÍA GUIDE RING	2	POLIACETAL + Mb POLYACETAL + Mb
11	JUNTA TÓRICA ÉMBOLO PISTON O-RING	2	N.B.R. N.B.R.
12	JUNTA TÓRICA EJE SHAFT O-RING	2	N.B.R. N.B.R.
13	JUNTA TÓRICA EJE SHAFT O-RING	2	N.B.R. N.B.R.
14	MUELLES PRECARGADOS PRELOADED SPRINGS	12	DIN-17223-C (6) (4) DIN-17223-C (6) (4)
15	LEVA CAM	1	ACERO (2) STEEL (2)
16	EJE SHAFT	1	ACERO (2) STEEL (2)
17	JUNTA TÓRICA PLACA PLATE O-RING	2	N.B.R. N.B.R.
18	TUERCA NUT	4	ACERO INOXIDABLE AISI-304 AISI-304 STAINLESS STEEL
19	PLACA CONEXIÓN NEUMÁTICA PNEUMATIC CONNECTION PLATE	1	POLIAMIDA + FV POLYAMIDE + FG
20	TORNILLO ALLEN PLACA PLATE ALLEN SCREW	2	ACERO INOXIDABLE AISI-304 AISI-304 STAINLESS STEEL
21	TORNILLO HEXAGONAL HEXAGONAL SCREW	2	ACERO INOXIDABLE AISI-304 AISI-304 STAINLESS STEEL
22	TUERCA NUT	2	ACERO INOXIDABLE AISI-304 AISI-304 STAINLESS STEEL
23	ARANDELA BUSHING	2	ACERO INOXIDABLE AISI-316 AISI-316 STAINLESS STEEL
24	JUNTA TÓRICA O-RING	2	N.B.R. N.B.R.
25	PIÑÓN GEAR	1	ALEACIÓN ALUMINIO (5) ALUMINIUM ALLOY (5)

- (1) RECUBRIMIENTO CON POLIAMIDA.
COVERED WITH POLYAMIDE.
- (2) RECUBRIMIENTO POR CATAFORESIS.
COVERED BY CATAPHORESIS.
- (4) CANTIDAD VARIABLE, CONSULTAR
TABLAS PARES SIMPLE EFECTO.
VARIABLE QUANTITY, PLEASE SEE THE
SPRING RETURN TORQUE CHART.
- (5) BRUÑIDO CON BOLAS.
BALL BURNISHING.
- (6) PASIVADO DE CROMO TRIVALENTE.
TRIVALENT CHROMINIUM PASSIVATION.
- (7) RECUBRIMIENTO CON POLIURETANO.
COVERED WITH POLYURETHANE.

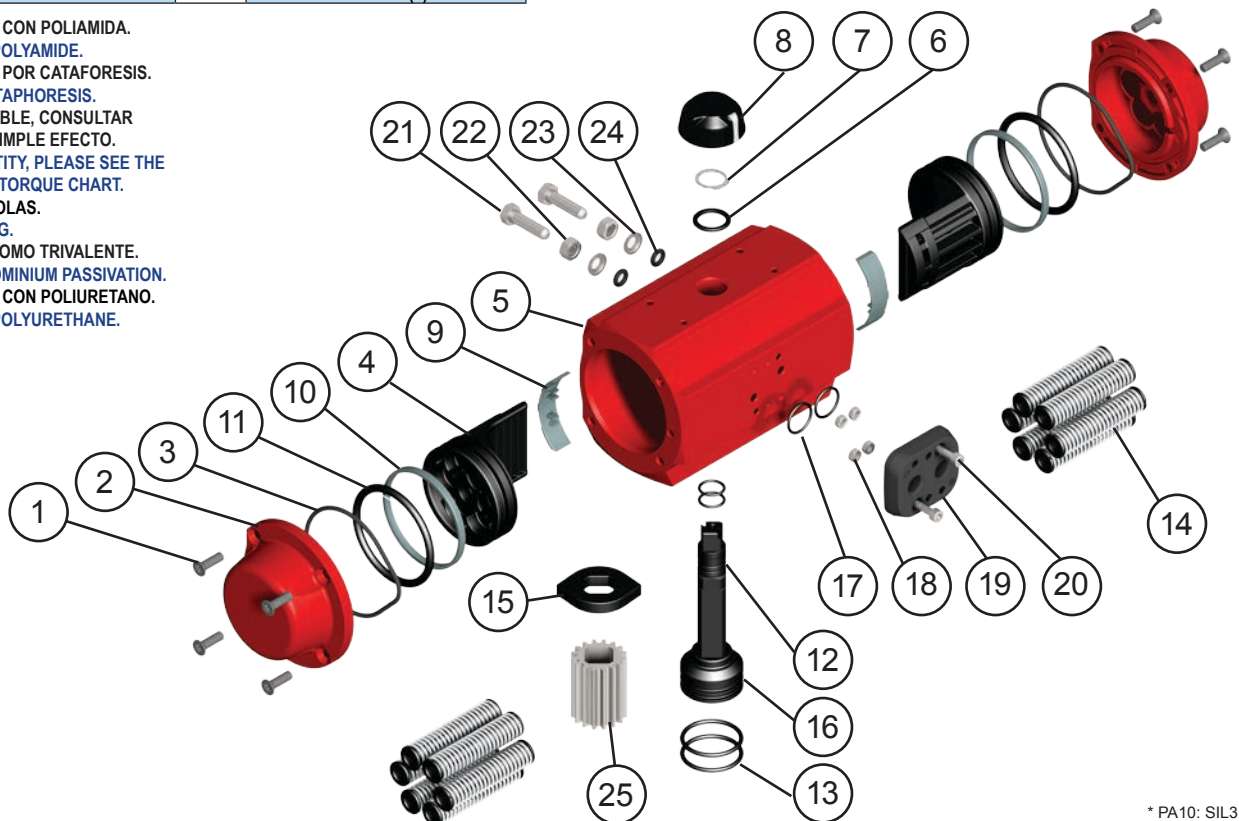

* PA10: SIL3
PA10S: SIL2 / SIL3 (SC)

MODELOS MODELS	TIEMPO DE MANIOBRA EN SEG. CYCLE TIME IN SECS.		PESOS WEIGHTS		CAPACIDAD EN LITROS CAPACITY IN LITRES	
	PARA ABRIR TO OPEN	PARA CERRAR TO CLOSE	Kg.	Lb.	PARA ABRIR TO OPEN	PARA CERRAR TO CLOSE
PA10	0,25	0,25	3,08	6,79	0,35	0,45
PA10S	0,3	0,3	3,48	7,68	0,35	

Tiempo de maniobra sin par resistente a 6 bar.
Cycle time w/o resistant torque at 6 bar.

Dimensiones en mm.
Dimensions in mm.

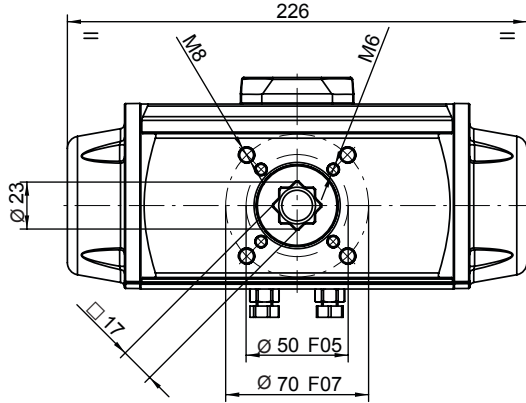

Para calcular el consumo, multiplicar las cifras del cuadro por la presión real de trabajo.

To calculate the consumption, multiply the above figures by the real working pressure.

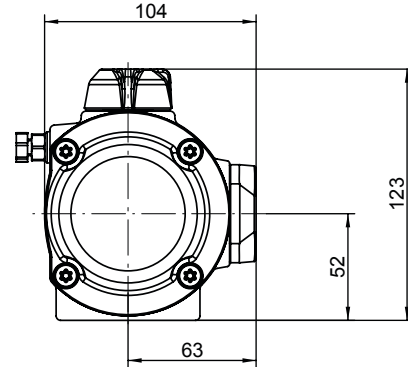
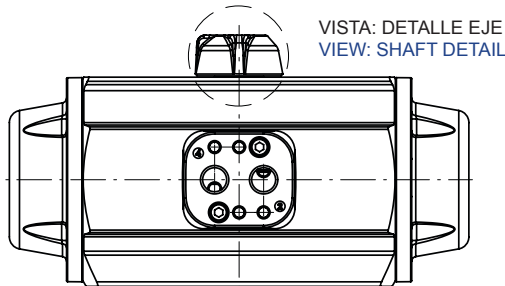
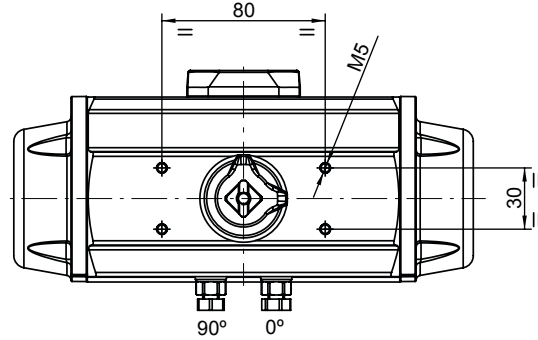

PARES DOBLE EFECTO DOUBLE ACTING TORQUES

PA10	PRESION AIRE AIR PRESSURE							
bar	3	4	4,5	5	5,5	6	7	8
p.s.i	43,5	58	65,3	72,5	79,8	87	101,5	116
Nm	32,9	45,6	52	58,3	65	71	83,7	96,4
Lb.in	291	404	460	516	575	628	741	853

PARES SIMPLE EFECTO SPRING RETURN TORQUES

PA10S	PAR MUELLES SPRING TORQUES		PAR A LA PRESIÓN INDICADA AIR TORQUE AT INDICATED PRESSURE																		
			3		4		4,5		5		5,5		6		7		8		bar		
N	INICIAL INITIAL	FINAL END	43,5		58		65,3		72,5		79,8		87		101,5		116		p.s.i		
6*	45,6	30,8							21,2	6,4	27,5	12,7	34,2	19,4	40,2	25,4	52,9	38,1	65,6	50,8	Nm
	403,6	272,6							187,4	56,4	243,4	112,4	302,7	171,7	355,8	224,8	468,2	337,2	580,6	449,6	Lb.in
5	38	25,7			19,9	7,6	26,3	14	32,6	20,3	39,3	27	45,3	33	58	45,7	70,7	58,4			Nm
	336,3	227,5			176,1	67,3	232,5	123,7	288,5	179,7	347,8	239	400,9	292,1	513,3	404,5	625,7	516,9			Lb.in
4	30,4	20,5	12,4	2,5	25,1	15,2	31,5	21,6	37,8	27,9	44,5	34,6	50,5	40,6	63,2	53,3	75,9	66			Nm
	269,1	181,4	109,7	22,1	222,2	134,5	278,6	190,9	334,6	246,9	393,9	306,2	447	359,3	559,4	471,7	671,8	584,1			Lb.in
3	22,8	15,4	17,5	10,1	30,2	22,8	36,6	29,2	42,9	35,5	49,6	42,2	55,6	48,2	68,3	60,9					Nm
	201,8	136,3	154,9	89,4	267,3	201,8	323,7	258,2	379,7	314,2	439	373,5	492,1	426,6	604,5	539,0					Lb.in
2	15,2	10,3	22,6	17,7	35,3	30,4	41,7	36,8	48	43,1	54,7	49,8	60,7	55,8							Nm
	134,5	91,2	200	156,7	312,4	269,1	368,8	325,5	424,8	381,5	484,1	440,8	537,2	493,9							Lb.in

N: Número de muelles por banda
Number of springs per side

* Número de muelles estándar
* Standard number of springs

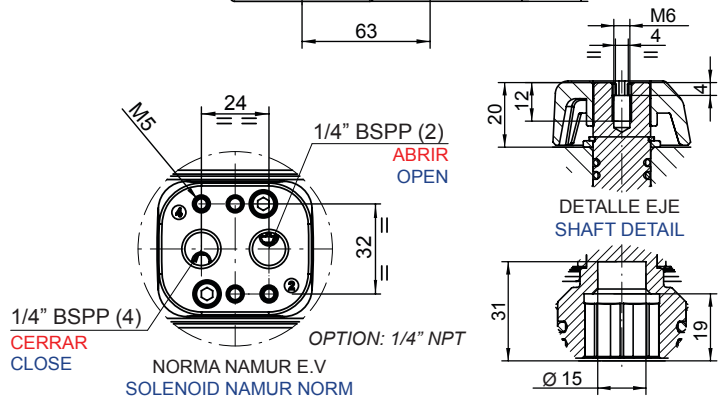

DESPIECE

DISASSEMBLY



ACTUADOR NEUMÁTICO DE ALUMINIO
ALUMINIUM PNEUMATIC ACTUATOR



PA15: Doble Efecto / Double Acting

PA15S: Simple Efecto / Spring Return

Nº	Descripción Description	Cant. Quant.	Material Material
1	TORNILLO AVELLANADO TAPA CAP COUNTERSUNK SCREW	8	ACERO INOXIDABLE AISI-304 AISI-304 STAINLESS STEEL
2	TAPA CAP	2	ALEACIÓN ALUMINIO (2) + (7) ALUMINIUM ALLOY (2) + (7)
3	JUNTA TÓRICA TAPA CAP-O-RING	2	N.B.R. N.B.R.
4	ÉMBOLO PISTON	2	ALEACIÓN ALUMINIO (2) ALUMINIUM ALLOY (2)
5	CILINDRO CYLINDER	1	ALEACIÓN DE ALUMINIO (2) + (1) ALUMINIUM ALLOY (2) + (1)
6	ARANDELA WASHER	1	POLIACETAL POLYACETAL
7	ANILLO DE SEGURIDAD SPRING CLIP	1	ACERO INOXIDABLE STAINLESS STEEL
8	INDICADOR VISUAL POSITION INDICATOR	1	POLIAMIDA POLYAMIDE
9	GUIA ÉMBOLO PISTON GUIDE	2	POLIACETAL + Mb POLYACETAL + Mb
10	ANILLO GUIA GUIDE RING	2	POLIACETAL + Mb POLYACETAL + Mb
11	JUNTA TÓRICA ÉMBOLO PISTON O-RING	2	N.B.R. N.B.R.
12	JUNTA TÓRICA EJE SHAFT O-RING	2	N.B.R. N.B.R.
13	JUNTA TÓRICA EJE SHAFT O-RING	2	N.B.R. N.B.R.
14	MUELLES PRECARGADOS PRELOADED SPRINGS	12	DIN-17223-C (6) (4) DIN-17223-C (6) (4)
15	LEVA CAM	1	ACERO (2) STEEL (2)
16	EJE SHAFT	1	ACERO (2) STEEL (2)
17	JUNTA TÓRICA PLACA PLATE O-RING	2	N.B.R. N.B.R.
18	TUERCA NUT	4	ACERO INOXIDABLE AISI-304 AISI-304 STAINLESS STEEL
19	PLACA CONEXIÓN NEUMÁTICA PNEUMATIC CONNECTION PLATE	1	POLIAMIDA + FV POLYAMIDE + FG
20	TORNILLO ALLEN PLACA PLATE ALLEN SCREW	2	ACERO INOXIDABLE AISI-304 AISI-304 STAINLESS STEEL
21	TORNILLO HEXAGONAL HEXAGONAL SCREW	2	ACERO INOXIDABLE AISI-304 AISI-304 STAINLESS STEEL
22	TUERCA NUT	2	ACERO INOXIDABLE AISI-304 AISI-304 STAINLESS STEEL
23	ARANDELA BUSHING	2	ACERO INOXIDABLE AISI-316 AISI-316 STAINLESS STEEL
24	JUNTA TÓRICA O-RING	2	N.B.R. N.B.R.
25	PIÑÓN GEAR	1	ALEACIÓN ALUMINIO (5) ALUMINIUM ALLOY (5)

- (1) RECUBRIMIENTO CON POLIAMIDA.
COVERED WITH POLYAMIDE.
- (2) RECUBRIMIENTO POR CATAFORESIS.
COVERED BY CATHAPHORESIS.
- (4) CANTIDAD VARIABLE, CONSULTAR
TABLAS PARES SIMPLE EFECTO.
VARIABLE QUANTITY, PLEASE SEE THE
SPRING RETURN TORQUE CHART.
- (5) BRUÑIDO CON BOLAS.
BALL BURNISHING.
- (6) PASIVADO DE CROMO TRIVALENTE.
TRIVALENT CHROMINIUM PASSIVATION.
- (7) RECUBRIMIENTO CON POLIURETANO.
COVERED WITH POLYURETHANE.

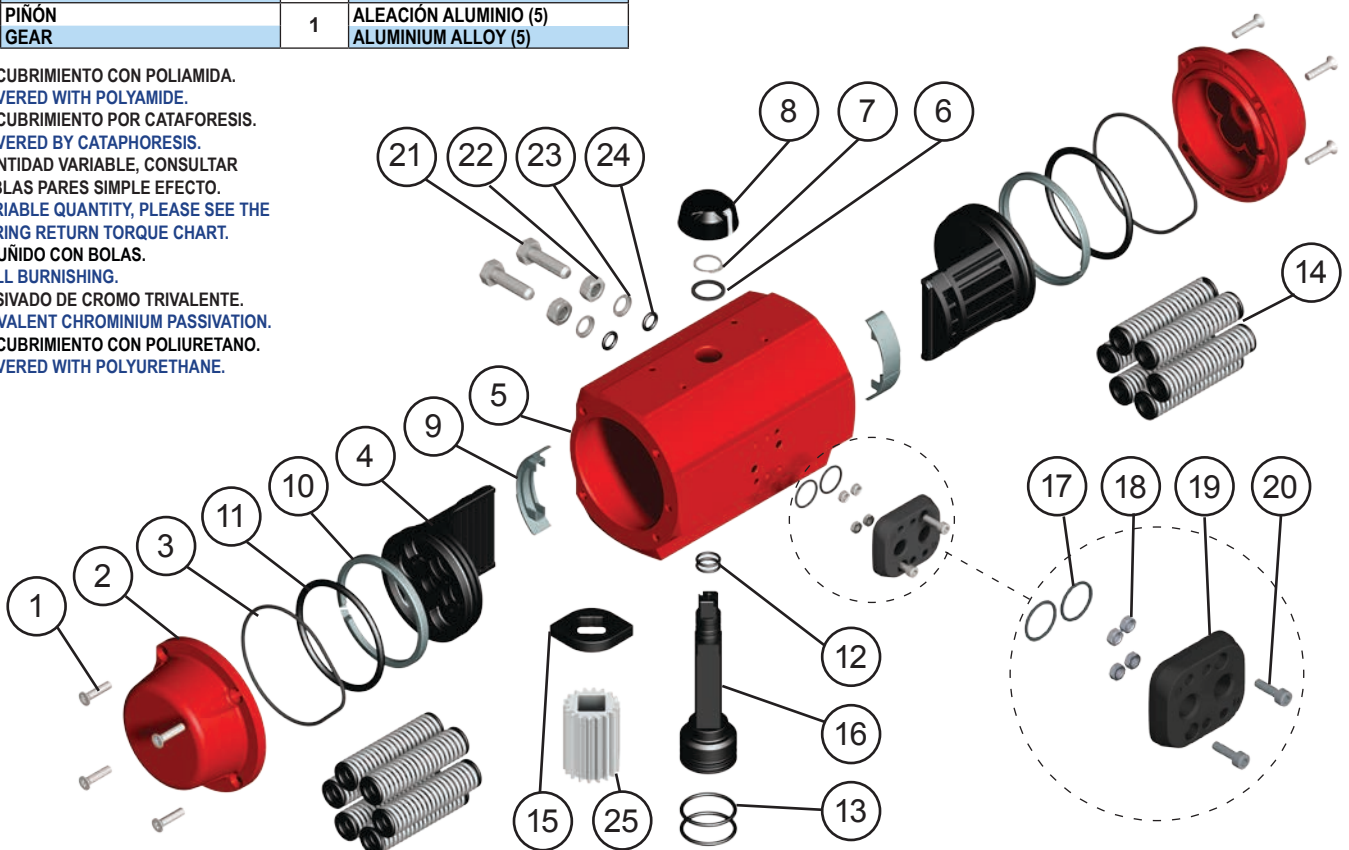

* PA15: SIL3
PA15S: SIL2 / SIL3 (SC)

MODELOS MODELS	TIEMPO DE MANIOBRA EN SEG. CYCLE TIME IN SECS.		PESOS WEIGHTS		CAPACIDAD EN LITROS CAPACITY IN LITRES	
	PARA ABRIR TO OPEN	PARA CERRAR TO CLOSE	Kg.	Lb.	PARA ABRIR TO OPEN	PARA CERRAR TO CLOSE
PA15	0,3	0,3	4,20	9,25	0,65	0,82
PA15S	0,4	0,4	5,04	11,10	0,65	

Tiempo de maniobra sin par resistente a 6 bar.
Cycle time w/o resistant torque at 6 bar.

Dimensiones en mm.
Dimensions in mm.

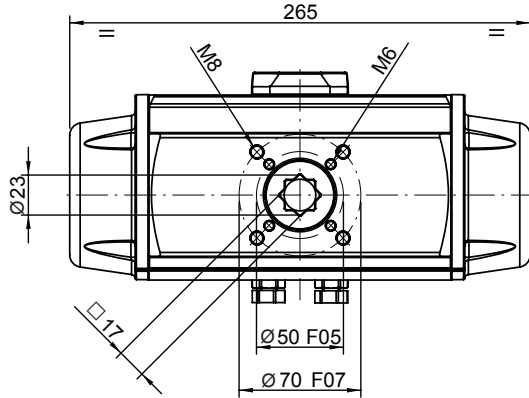

Para calcular el consumo, multiplicar las cifras del cuadro por la presión real de trabajo.

To calculate the consumption, multiply the above figures by the real working pressure.

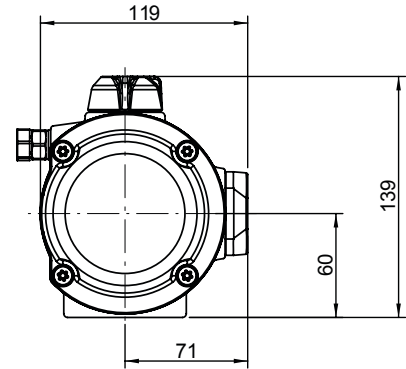
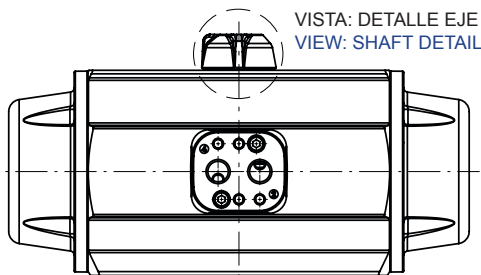
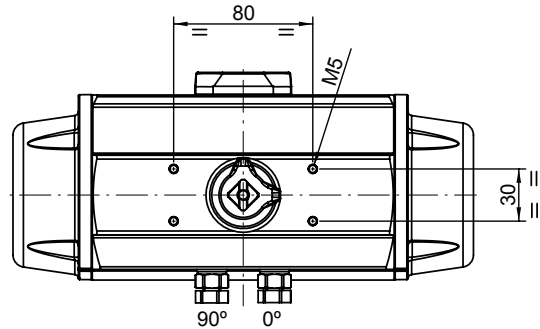

PARES DOBLE EFECTO DOUBLE ACTING TORQUES

PA15	PRESION AIRE AIR PRESSURE							
bar	3	4	4,5	5	5,5	6	7	8
p.s.i	43,5	58	65,3	72,5	79,8	87	101,5	116
Nm	55,2	75,6	85,8	96	106,2	116,5	136,9	157,4
Lb.in	489	669	759,5	850	940	1.031	1.212	1.393

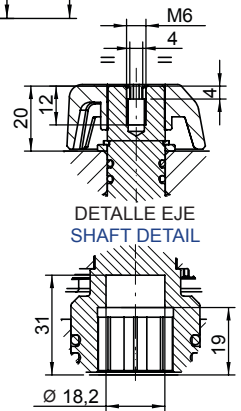
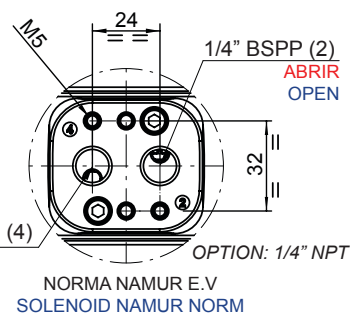

PARES SIMPLE EFECTO SPRING RETURN TORQUES

PA15S	PAR MUELLES SPRING TORQUES		PAR A LA PRESIÓN INDICADA AIR TORQUE AT INDICATED PRESSURE																	
			3	4	4,5	5	5,5	6	7	8	bar									
		43,5	58	65,3	72,5	79,8	87	101,5	116	p.s.i										
N	INICIAL INITIAL	FINAL END	INICIAL INITIAL	FINAL END	INICIAL INITIAL	FINAL END	INICIAL INITIAL	FINAL END	INICIAL INITIAL	FINAL END	INICIAL INITIAL	FINAL END	INICIAL INITIAL	FINAL END	INICIAL INITIAL	FINAL END	INICIAL INITIAL	FINAL END		
6*	71,5	49					36,8	14,3	47	24,5	57,2	34,7	67,5	45	87,9	65,4	108,4	85,9	Nm	
	632,8	433,7					325,8	126,7	416	216,8	506,3	307,1	597,4	398,3	778	578,8	959,4	760,3	Lb.in	
5	59,6	40,9			34,7	16	44,9	26,2	55,1	36,4	65,3	46,6	75,6	56,9	96	77,3	116,5	97,8	Nm	
	527,5	362			307,1	141,6	397,5	232	487,7	322,2	578	412,4	669,1	503,6	849,7	684,2	1.031	865,6	Lb.in	
4	47,7	32,7	22,5	7,5	42,9	27,9	53,1	38,1	63,3	48,3	73,5	58,5	83,8	68,8	104,2	89,2	124,7	109,7	Nm	
	422,2	289,4	199,1	66,4	379,7	246,9	470,1	337,3	560,3	427,5	650,5	517,8	741,7	608,9	922,2	789,5	1.104	970,9	Lb.in	
3	35,7	24,5	30,7	19,5	51,1	39,9	61,3	50,1	71,5	60,3	81,7	70,5	92	80,8	112,4	101,2			Nm	
	316	216,8	271,7	172,6	452,3	353,1	542,7	443,5	632,8	533,7	723,1	624	814,3	715,1	994,8	895,7			Lb.in	
2	23,8	16,3	38,9	31,4	59,3	51,8	69,5	62	79,7	72,2	89,9	82,4	100,2	92,7					Nm	
	210,6	144,3	344,3	277,9	524,8	458,5	615,2	548,9	705,4	639	795,7	729,3	886,8	820,5					Lb.in	

N: Número de muelles por banda
Number of springs per side

* Número de muelles estándar
* Standard number of springs

DESPIECE

DISASSEMBLY

Nº	Descripción Description	Cant. Quant.	Material Material
1	TORNILLO ALLEN TAPA CAP ALLEN SCREW	8	ACERO INOXIDABLE AISI-304 AISI-304 STAINLESS STEEL
2	TAPA CAP	2	ALEACIÓN ALUMINIO (2) + (7) ALUMINIUM ALLOY (2) + (7)
3	JUNTA TÓRICA TAPA CAP-O-RING	2	N.B.R. N.B.R.
4	ÉMBOLO PISTON	2	ALEACIÓN ALUMINIO (2) ALUMINIUM ALLOY (2)
5	CILINDRO CYLINDER	1	ALEACIÓN DE ALUMINIO (2) + (1) ALUMINIUM ALLOY (2) + (1)
6	ARANDELA WASHER	1	POLIACETAL POLYACETAL
7	ANILLO DE SEGURIDAD SPRING CLIP	1	ACERO (3) STEEL (3)
8	INDICADOR VISUAL POSITION INDICATOR	1	POLIAMIDA POLYAMIDE
9	GUÍA ÉMBOLO PISTON GUIDE	2	POLIACETAL + Mb POLYACETAL + Mb
10	ANILLO GUÍA GUIDE RING	2	POLIACETAL + Mb POLYACETAL + Mb
11	JUNTA TÓRICA ÉMBOLO PISTON O-RING	2	N.B.R. N.B.R.
12	JUNTA TÓRICA EJE SHAFT O-RING	2	N.B.R. N.B.R.
13	JUNTA TÓRICA EJE SHAFT O-RING	2	N.B.R. N.B.R.
14	MUELLES PRECARGADOS PRELOADED SPRINGS	12	DIN-17223-C (6) (4) DIN-17223-C (6) (4)
15	LEVA CAM	1	ACERO (2) STEEL (2)
16	EJE SHAFT	1	ACERO (2) STEEL (2)
17	JUNTA TÓRICA PLACA PLATE O-RING	2	N.B.R. N.B.R.
18	TUERCA NUT	4	ACERO INOXIDABLE AISI-304 AISI-304 STAINLESS STEEL
19	PLACA CONEXIÓN NEUMÁTICA PNEUMATIC CONNECTION PLATE	1	POLIAMIDA + FV POLYAMIDE + FG
20	TORNILLO ALLEN PLACA PLATE ALLEN SCREW	2	ACERO INOXIDABLE AISI-304 AISI-304 STAINLESS STEEL
21	TORNILLO HEXAGONAL HEXAGONAL SCREW	2	ACERO INOXIDABLE AISI-304 AISI-304 STAINLESS STEEL
22	TUERCA NUT	2	ACERO INOXIDABLE AISI-304 AISI-304 STAINLESS STEEL
23	ARANDELA BUSHING	2	ACERO INOXIDABLE AISI-316 AISI-316 STAINLESS STEEL
24	JUNTA TÓRICA O-RING	2	N.B.R. N.B.R.
25	PIÑÓN GEAR	1	ALEACIÓN ALUMINIO (5) ALUMINIUM ALLOY (5)
26	ARANDELA TAPA CAP WASHER	8	ACERO INOXIDABLE AISI-304 AISI-304 STAINLESS STEEL

- (1) RECUBRIMIENTO CON POLIAMIDA.
COVERED WITH POLYAMIDE.
- (2) RECUBRIMIENTO POR CATAFORESIS.
COVERED BY CATAFORESIS.
- (3) RECUBIERTO CON NÍQUEL-TEFLON.
COVERED BY NIKEL-P.T.F.E.
- (4) CANTIDAD VARIABLE, CONSULTAR
TABLAS PARES SIMPLE EFECTO.
VARIABLE QUANTITY, PLEASE SEE THE
SPRING RETURN TORQUE CHART.
- (5) BRUÑIDO CON BOLAS.
BALL BURNISHING.
- (6) PASIVADO DE CROMO TRIVALENTE.
TRIVALENT CHROMINIUM PASSIVATION.
- (7) RECUBRIMIENTO CON POLIURETANO.
COVERED WITH POLYURETHANE.

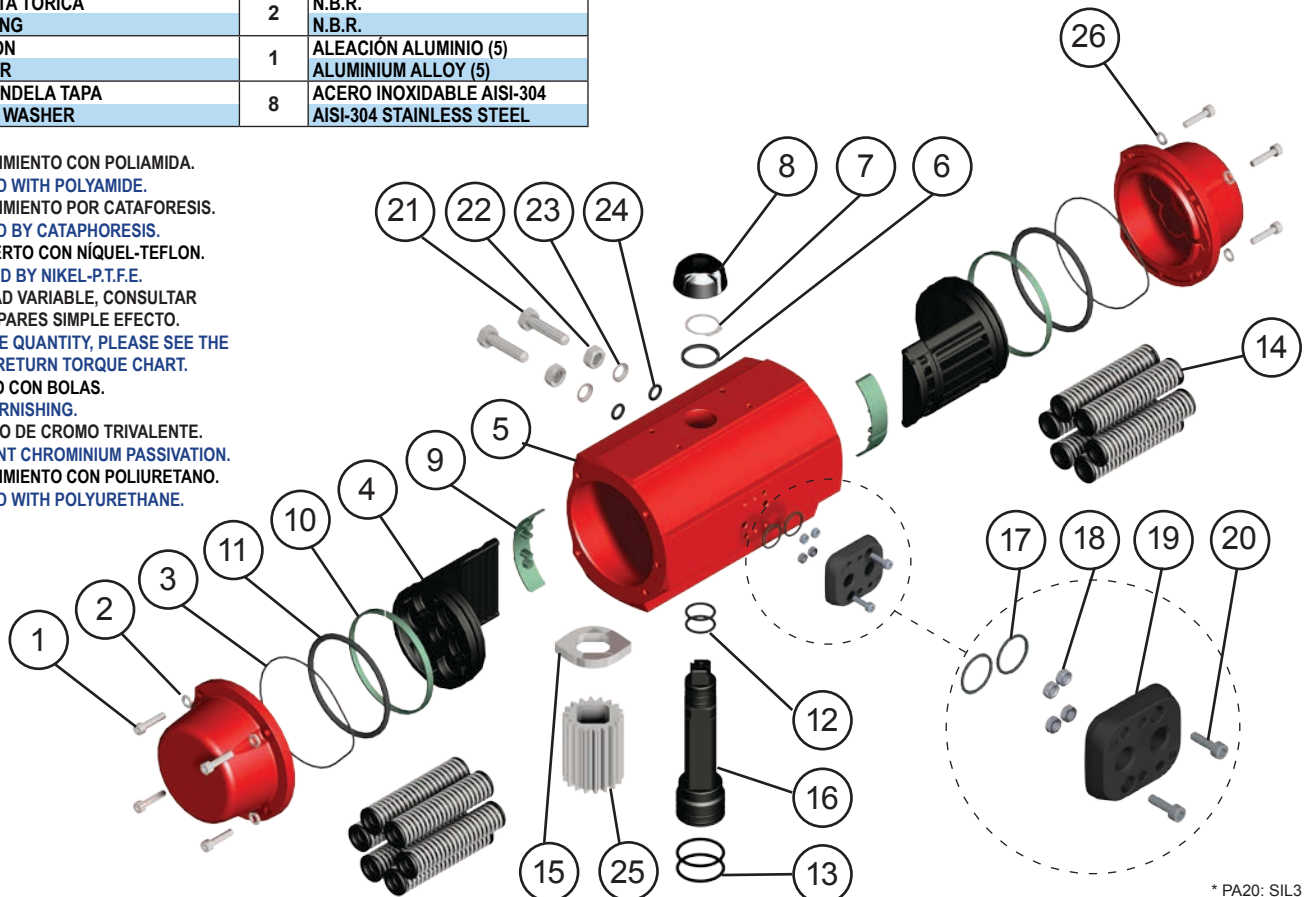

ACTUADOR NEUMÁTICO DE ALUMINIO
ALUMINIUM PNEUMATIC ACTUATOR



PA20: Doble Efecto / Double Acting

PA20S: Simple Efecto / Spring Return

* PA20: SIL3
PA20S: SIL2 / SIL3 (SC)

MODELOS MODELS	TIEMPO DE MANIOBRA EN SEG. CYCLE TIME IN SECS.		PESOS WEIGHTS		CAPACIDAD EN LITROS CAPACITY IN LITRES	
	PARA ABRIR TO OPEN	PARA CERRAR TO CLOSE	Kg.	Lb.	PARA ABRIR TO OPEN	PARA CERRAR TO CLOSE
PA20	0,4	0,4	5,61	12,36	0,8	1,15
PA20S	0,5	0,5	6,63	14,61	0,8	

Tiempo de maniobra sin par resistente a 6 bar.
Cycle time w/o resistant torque at 6 bar.

Dimensiones en mm.
Dimensions in mm.

Para calcular el consumo, multiplicar las cifras del cuadro por la presión real de trabajo.

To calculate the consumption, multiply the above figures by the real working pressure.

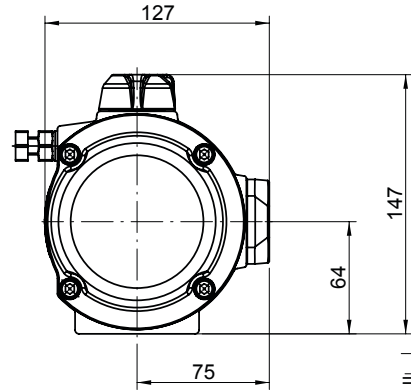
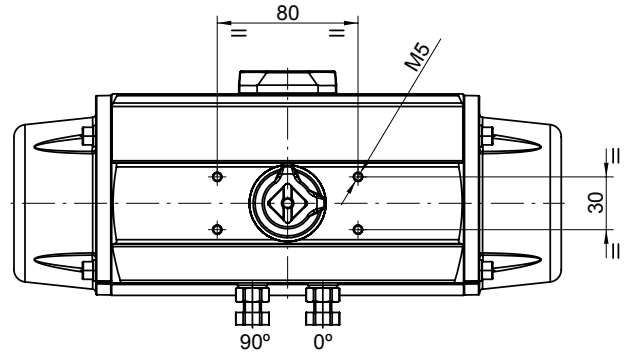
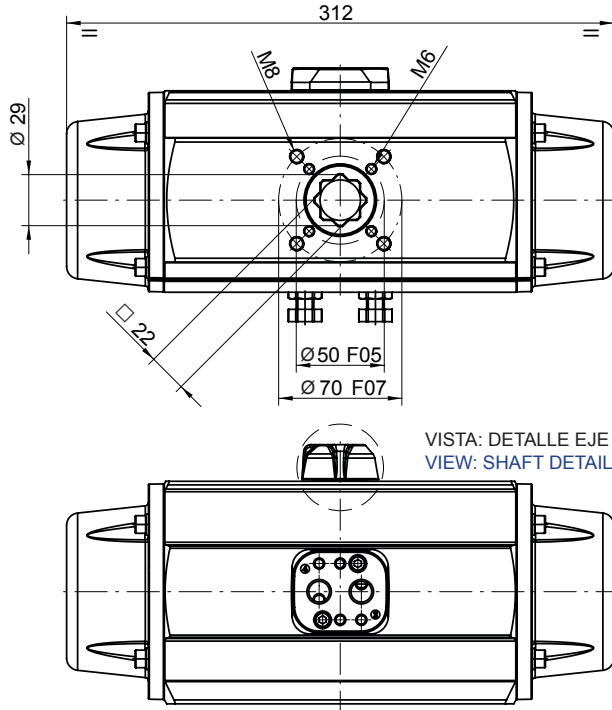

PARES DOBLE EFECTO DOUBLE ACTING TORQUES

PA20	PRESION AIRE AIR PRESSURE							
bar	3	4	4,5	5	5,5	6	7	8
p.s.i	43,5	58	65,3	72,5	79,8	87	101,5	116
Nm	77,7	107	121,7	136,3	151	165,5	194,8	224
Lb.in	688	947	1.076	1.206	1.336	1.465	1.724	1.983

PARES SIMPLE EFECTO SPRING RETURN TORQUES

PA20S	PAR MUELLES SPRING TORQUES		PAR A LA PRESIÓN INDICADA AIR TORQUE AT INDICATED PRESSURE																
	INICIAL INITIAL	FINAL END	3 43,5		4 58		4,5 65,3		5 72,5		5,5 79,8		6 87		7 101,5		8 116		bar p.s.i
N	INICIAL	FINAL	INICIAL	FINAL	INICIAL	FINAL	INICIAL	FINAL	INICIAL	FINAL	INICIAL	FINAL	INICIAL	FINAL	INICIAL	FINAL	INICIAL	FINAL	
6*	104,7	65,8					55,9	17	70,5	31,6	85,2	46,3	99,7	60,8	129	90,1	158,2	119,3	Nm
	926,7	582,4					494,1	149,8	624	279,7	754,1	409,8	882,4	538,1	1.142	797	1.400	1.056	Lb.in
5	87,2	54,8			52,2	19,8	66,9	34,5	81,5	49,1	96,2	63,8	110,7	78,3	140	107,6	169,2	136,8	Nm
	771,8	485			462	175	591,5	304,7	721,3	434,6	851,4	564,7	980	693	1.239	952,3	1.497	1.211	Lb.in
4	69,8	43,9	33,8	8	63,1	37,2	77,8	51,9	92,4	66,5	107,1	81,2	121,6	95,7	150,9	125	180,1	154,2	Nm
	617,8	388,5	299,2	69,9	558,5	329,2	688	458,7	817,8	588,6	947,9	718,7	1.076	847	1.336	1.106	1.594	1.365	Lb.in
3	52,3	32,9	44,8	25,4	74,1	54,7	88,8	69,4	103,4	84	118,1	98,7	132,6	113,2	161,9	142,5			Nm
	462,9	291,2	396,5	224,8	655,8	484,1	785,3	613,6	915,2	743,5	1045	873,6	1.174	1.002	1.433	1.261			Lb.in
2	34,9	21,9	55,8	42,8	85,1	72,1	99,8	86,8	114,4	101,4	129,1	116,1	143,6	130,6					Nm
	308,9	193,8	493,9	378,8	753,2	638,1	882,7	767,6	1.012	897,5	1.143	1.027	1.271	1.156					Lb.in

N: Número de muelles por banda
Number of springs per side

* Número de muelles estándar
* Standard number of springs

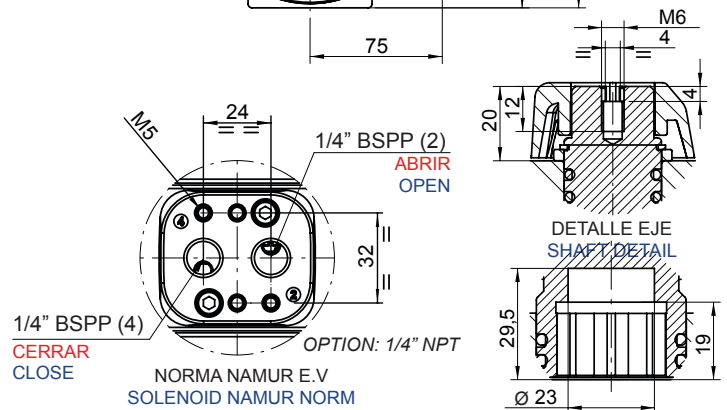

DESPIECE

DISASSEMBLY



ACTUADOR NEUMÁTICO DE ALUMINIO
ALUMINIUM PNEUMATIC ACTUATOR



PA25: Doble Efecto / Double Acting
PA25S: Simple Efecto / Spring Return

Nº	Descripción Description	Cant. Quant.	Material Material
1	TORNILLO ALLEN TAPA CAP ALLEN SCREW	8	ACERO INOXIDABLE AISI-304 AISI-304 STAINLESS STEEL
2	TAPA CAP	2	ALEACIÓN ALUMINIO (2) + (7) ALUMINIUM ALLOY (2) + (7)
3	JUNTA TÓRICA TAPA CAP-O-RING	2	N.B.R. N.B.R.
4	ÉMBOLO PISTON	2	ALEACIÓN ALUMINIO (2) ALUMINIUM ALLOY (2)
5	CILINDRO CYLINDER	1	ALEACIÓN DE ALUMINIO (2) + (1) ALUMINIUM ALLOY (2) + (1)
6	ARANDELA WASHER	1	POLIACETAL POLYACETAL
7	ANILLO DE SEGURIDAD SPRING CLIP	1	ACERO (3) STEEL (3)
8	INDICADOR VISUAL POSITION INDICATOR	1	POLIAMIDA POLYAMIDE
9	GUIA ÉMBOLO PISTON GUIDE	2	POLIACETAL + Mb POLYACETAL+ Mb
10	ANILLO GUIA GUIDE RING	2	POLIACETAL + Mb POLYACETAL + Mb
11	JUNTA TÓRICA ÉMBOLO PISTON O-RING	2	N.B.R. N.B.R.
12	JUNTA TÓRICA EJE SHAFT O-RING	2	N.B.R. N.B.R.
13	JUNTA TÓRICA EJE SHAFT O-RING	2	N.B.R. N.B.R.
14	MUELLES PRECARGADOS PRELOADED SPRINGS	12	DIN-17223-C (2) (4) DIN-17223-C (2) (4)
15	LEVA CAM	1	ACERO (2) STEEL (2)
16	EJE SHAFT	1	ACERO (2) STEEL (2)
17	JUNTA TÓRICA PLACA PLATE O-RING	2	N.B.R. N.B.R.
18	TUERCA NUT	4	ACERO INOXIDABLE AISI-304 AISI-304 STAINLESS STEEL
19	PLACA CONEXIÓN NEUMÁTICA PNEUMATIC CONNECTION PLATE	1	POLIAMIDA + FV POLYAMIDE + FG
20	TORNILLO ALLEN PLACA PLATE ALLEN SCREW	2	ACERO INOXIDABLE AISI-304 AISI-304 STAINLESS STEEL
21	TORNILLO HEXAGONAL HEXAGONAL SCREW	2	ACERO INOXIDABLE AISI-304 AISI-304 STAINLESS STEEL
22	TUERCA NUT	2	ACERO INOXIDABLE AISI-304 AISI-304 STAINLESS STEEL
23	ARANDELA BUSHING	2	ACERO INOXIDABLE AISI-316 AISI-316 STAINLESS STEEL
24	JUNTA TÓRICA O-RING	2	N.B.R. N.B.R.
25	PIÑÓN GEAR	1	ALEACIÓN ALUMINIO (5) ALUMINIUM ALLOY (5)
26	ARANDELA TAPA CAP WASHER	8	ACERO INOXIDABLE AISI-304 AISI-304 STAINLESS STEEL

- (1) RECUBRIMIENTO CON POLIAMIDA.
COVERED WITH POLYAMIDE.
- (2) RECUBRIMIENTO POR CATÁFORESIS.
COVERED BY CATHORESIS.
- (3) RECUBIERTO CON NÍQUEL-TEFLON.
COVERED BY NIKEL-P.T.F.E.
- (4) CANTIDAD VARIABLE, CONSULTAR
TABLAS PARES SIMPLE EFECTO.
VARIABLE QUANTITY, PLEASE SEE THE
SPRING RETURN TORQUE CHART.
- (5) BRUÑIDO CON BOLAS.
BALL BURNISHING.
- (7) RECUBRIMIENTO CON POLIURETANO.
COVERED WITH POLYURETHANE.

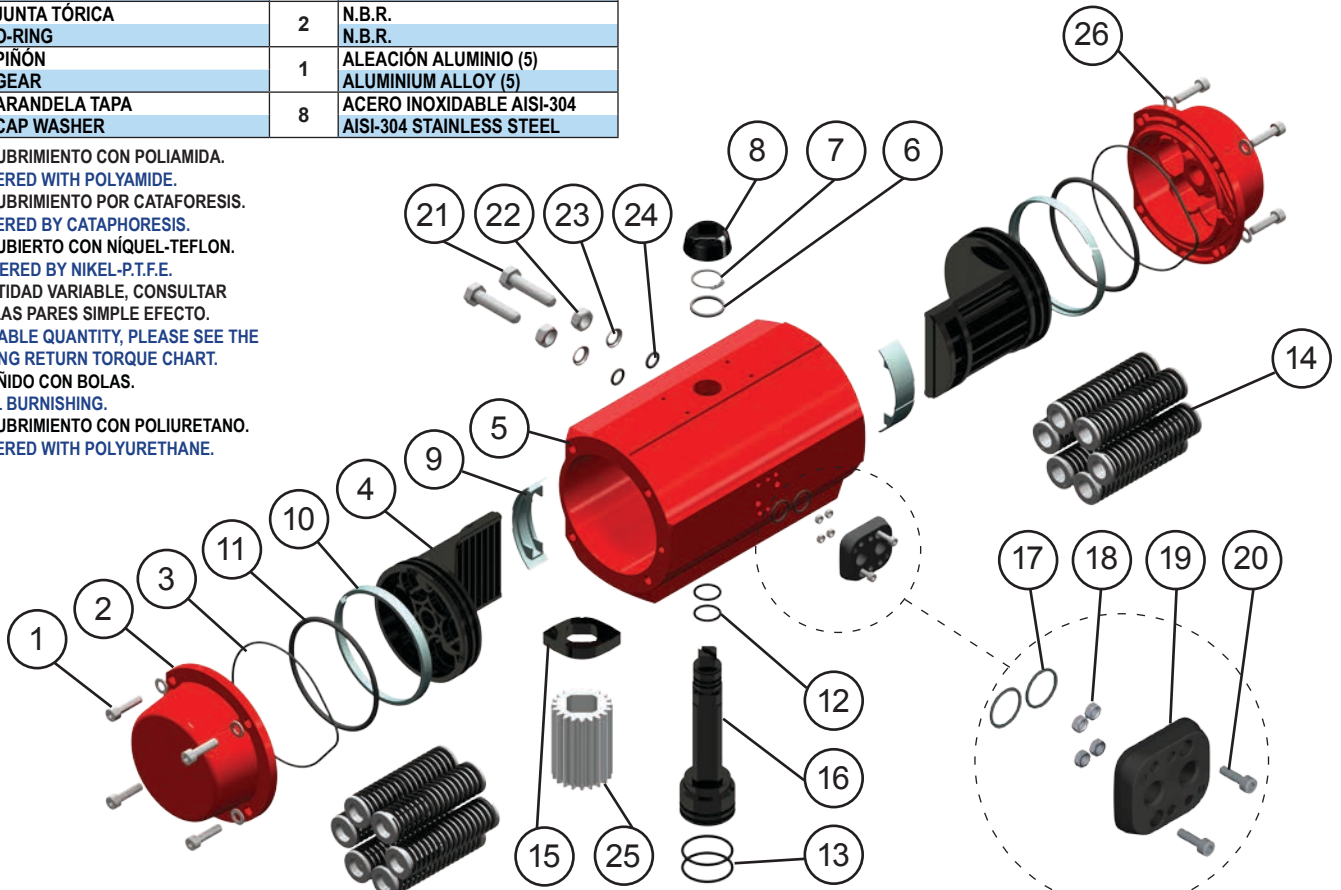

* PA25: SIL3
PA25S: SIL2 / SIL3 (SC)

MODELOS MODELS	TIEMPO DE MANIOBRA EN SEG. CYCLE TIME IN SECS.		PESOS WEIGHTS		CAPACIDAD EN LITROS CAPACITY IN LITRES	
	PARA ABRIR TO OPEN	PARA CERRAR TO CLOSE	Kg.	Lb.	PARA ABRIR TO OPEN	PARA CERRAR TO CLOSE
PA25	0,5	0,5	9,30	20,50	1,5	2,02
PA25S	0,8	0,8	11,30	29,92	1,5	

Tiempo de maniobra sin par resistente a 6 bar.
Cycle time w/o resistant torque at 6 bar.

Dimensiones en mm.
Dimensions in mm.

Para calcular el consumo, multiplicar las cifras del cuadro por la presión real de trabajo.

To calculate the consumption, multiply the above figures by the real working pressure.

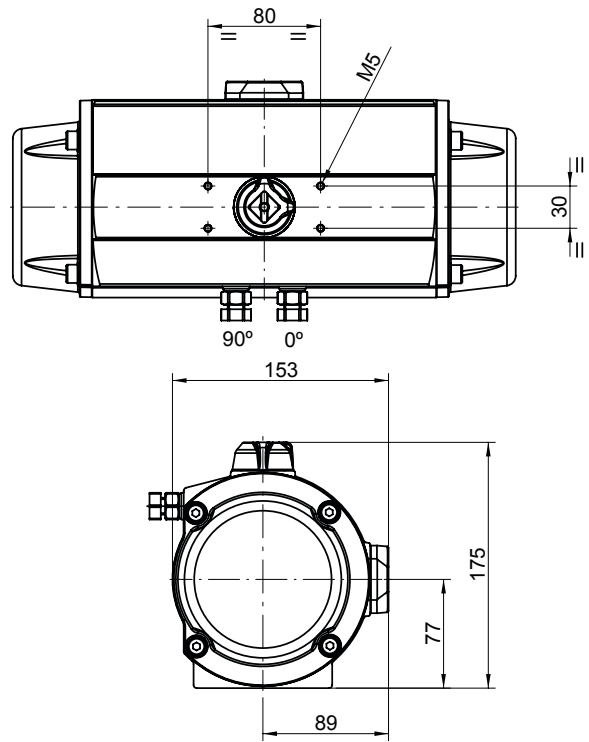
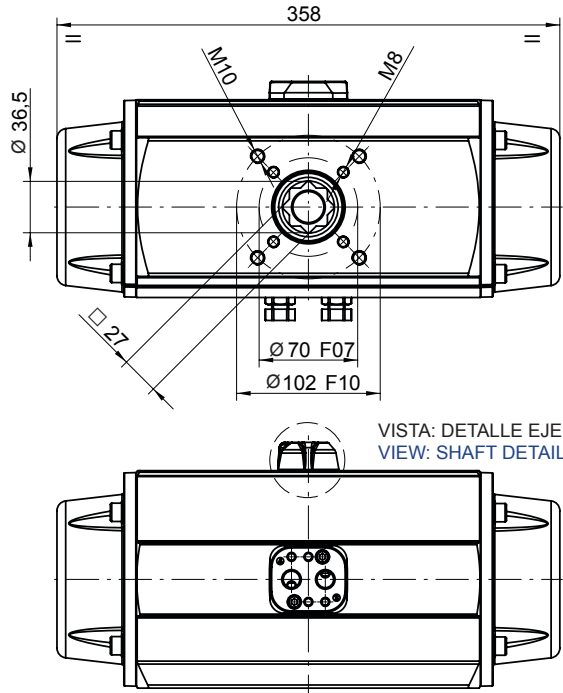

PARES DOBLE EFECTO DOUBLE ACTING TORQUES

PA25	PRESION AIRE AIR PRESSURE							
bar	3	4	4,5	5	5,5	6	7	8
p.s.i	43,5	58	65,3	72,5	79,8	87	101,5	116
Nm	140,1	190,1	215,1	240	264,9	290	339,9	393,9
Lb.in	1.240	1.683	1.903	2.124	2.345	2.567	3.008	3.486

PARES SIMPLE EFECTO SPRING RETURN TORQUES

PA25S	PAR MUELLES SPRING TORQUES		PAR A LA PRESIÓN INDICADA AIR TORQUE AT INDICATED PRESSURE																		
	INICIAL INITIAL	FINAL END	3		4		4,5		5		5,5		6		7		8		bar		
N			43,5		58		65,3		72,5		79,8		87		101,5		116		p.s.i		
6*	181,8	119,4							95,7	33,3	120,6	58,2	145,5	83,1	170,6	108,2	220,5	158,1	274,5	212,1	Nm
	1.609	1.057							846,5	294,5	1.067	515,1	1.288	735,5	1.510	957,6	1.952	1.399	2.429	1.877	Lb.in
5	151,5	99,5			90,6	38,6	115,6	63,6	140,5	88,5	165,4	113,4	190,5	138,5	240,4	188,4	294,4	242,4			Nm
	1.341	880,6			801,9	341,6	1.023	562,5	1.243	783,3	1.464	1.004	1.686	1.226	2.128	1.667	2.606	2.145			Lb.in
4	121,2	79,6	60,5	18,9	110,5	68,9	135,5	93,9	160,4	118,8	185,3	143,7	210,4	168,8	260,3	218,7	314,3	272,7			Nm
	1.072	704,5	535,5	167,3	978	609,8	1.199	831,5	1.420	1.051	1.640	1.272	1.862	1.494	2.304	1.936	2.782	2.414			Lb.in
3	90,9	59,7	80,4	49,2	130,4	99,2	155,4	124,2	180,3	149,1	205,2	174	230,3	199,1	280,2	249					Nm
	804,5	528,4	711,6	435,5	1.154	878	1.375	1.099	1.596	1.319	1.816	1.540	2.038	1.762	2.480	2.204					Lb.in
2	60,6	39,8	100,3	79,5	150,3	129,5	175,3	154,5	200,2	179,4	225,1	204,3	250,2	229,4							Nm
	536,4	352,3	887,7	703,6	1.330	1.146	1.551	1.367	1.772	1.588	1.992	1.808	2.214	2.030							Lb.in

N: Número de muelles por banda
Number of springs per side

* Número de muelles estándar
* Standard number of springs

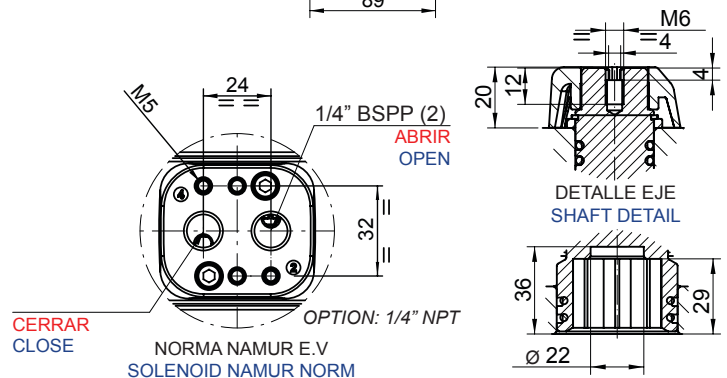

DESPIECE

DISASSEMBLY



Nº	Descripción Description	Cant. Quant.	Material Material
1	TORNILLO ALLEN TAPA CAP ALLEN SCREW	8	ACERO INOXIDABLE AISI-304 AISI-304 STAINLESS STEEL
2	TAPA CAP	2	ALEACIÓN ALUMINIO (2) + (7) ALUMINIUM ALLOY (2) + (7)
3	JUNTA TÓRICA TAPA CAP-O-RING	2	N.B.R. N.B.R.
4	ÉMBOLO PISTON	2	ALEACIÓN ALUMINIO (2) ALUMINIUM ALLOY (2)
5	CILINDRO CYLINDER	1	ALEACIÓN ALUMINIO (2) + (1) ALUMINIUM ALLOY (2) + (1)
6	ARANDELA WASHER	1	POLIACETAL POLYACETAL
7	ANILLO DE SEGURIDAD SPRING CLIP	1	ACERO (3) STEEL (3)
8	INDICADOR VISUAL POSITION INDICATOR	1	POLIAMIDA POLYAMIDE
9	GUIA ÉMBOLO PISTON GUIDE	4	POLIACETAL + Mb POLYACETAL + Mb
10	ANILLO GUIA GUIDE RING	2	POLIACETAL POLYACETAL
11	JUNTA TÓRICA ÉMBOLO PISTON O-RING	4	N.B.R. N.B.R.
12	JUNTA TÓRICA EJE SHAFT O-RING	2	N.B.R. N.B.R.
13	JUNTA TÓRICA EJE SHAFT O-RING	2	N.B.R. N.B.R.
14	MUELLES PRECARGADOS PRELOADED SPRINGS	12	DIN-17223-C (2) (4) DIN-17223-C (2) (4)
15	LEVA CAM	1	ACERO (2) STEEL (2)
16	EJE SHAFT	1	ACERO (2) STEEL (2)
17	JUNTA TÓRICA PLACA PLATE O-RING	2	N.B.R. N.B.R.
18	TUERCA NUT	4	ACERO INOXIDABLE AISI-304 AISI-304 STAINLESS STEEL
19	PLACA CONEXIÓN NEUMÁTICA PNEUMATIC CONNECTION PLATE	1	POLIAMIDA + FV POLYAMIDE + FG
20	TORNILLO ALLEN PLACA PLATE ALLEN SCREW	2	ACERO INOXIDABLE AISI-304 AISI-304 STAINLESS STEEL
21	TORNILLO HEXAGONAL HEXAGONAL SCREW	2	ACERO INOXIDABLE AISI-304 AISI-304 STAINLESS STEEL
22	TUERCA NUT	2	ACERO INOXIDABLE AISI-304 AISI-304 STAINLESS STEEL
23	ARANDELA BUSHING	2	ACERO INOXIDABLE AISI-316 AISI-316 STAINLESS STEEL
24	JUNTA TÓRICA O-RING	2	N.B.R. N.B.R.
25	PIÑÓN GEAR	1	ALEACIÓN ALUMINIO (5) ALUMINIUM ALLOY (5)
26	ARANDELA TAPA CAP WASHER	8	ACERO INOXIDABLE AISI-304 AISI-304 STAINLESS STEEL
27	JUNTA PLANA WATERTIGHTNESS PLANE GASKET	2	NEOPRENO NEOPRENE

ACTUADOR NEUMÁTICO DE ALUMINIO
ALUMINIUM PNEUMATIC ACTUATOR

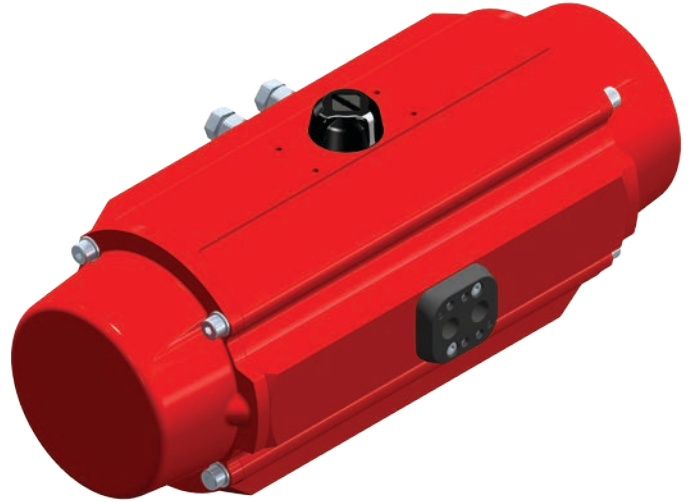

PA30: Doble Efecto / Double Acting

PA30S: Simple Efecto / Spring Return

- (1) RECUBRIMIENTO CON POLIAMIDA.
COVERED WITH POLYAMIDE.
- (2) RECUBRIMIENTO POR CATAFORESIS.
COVERED BY CATAPHORESIS.
- (3) RECUBIERTO CON NÍQUEL-TEFLON.
COVERED BY NIKEL-P.T.F.E.
- (4) CANTIDAD VARIABLE, CONSULTAR
TABLAS PARES SIMPLE EFECTO.
VARIABLE QUANTITY, PLEASE SEE THE
SPRING RETURN TORQUE CHART.
- (5) BRUÑIDO CON BOLAS.
BALL BURNISHING.
- (7) RECUBRIMIENTO CON POLIURETANO.
COVERED WITH POLYURETHANE.

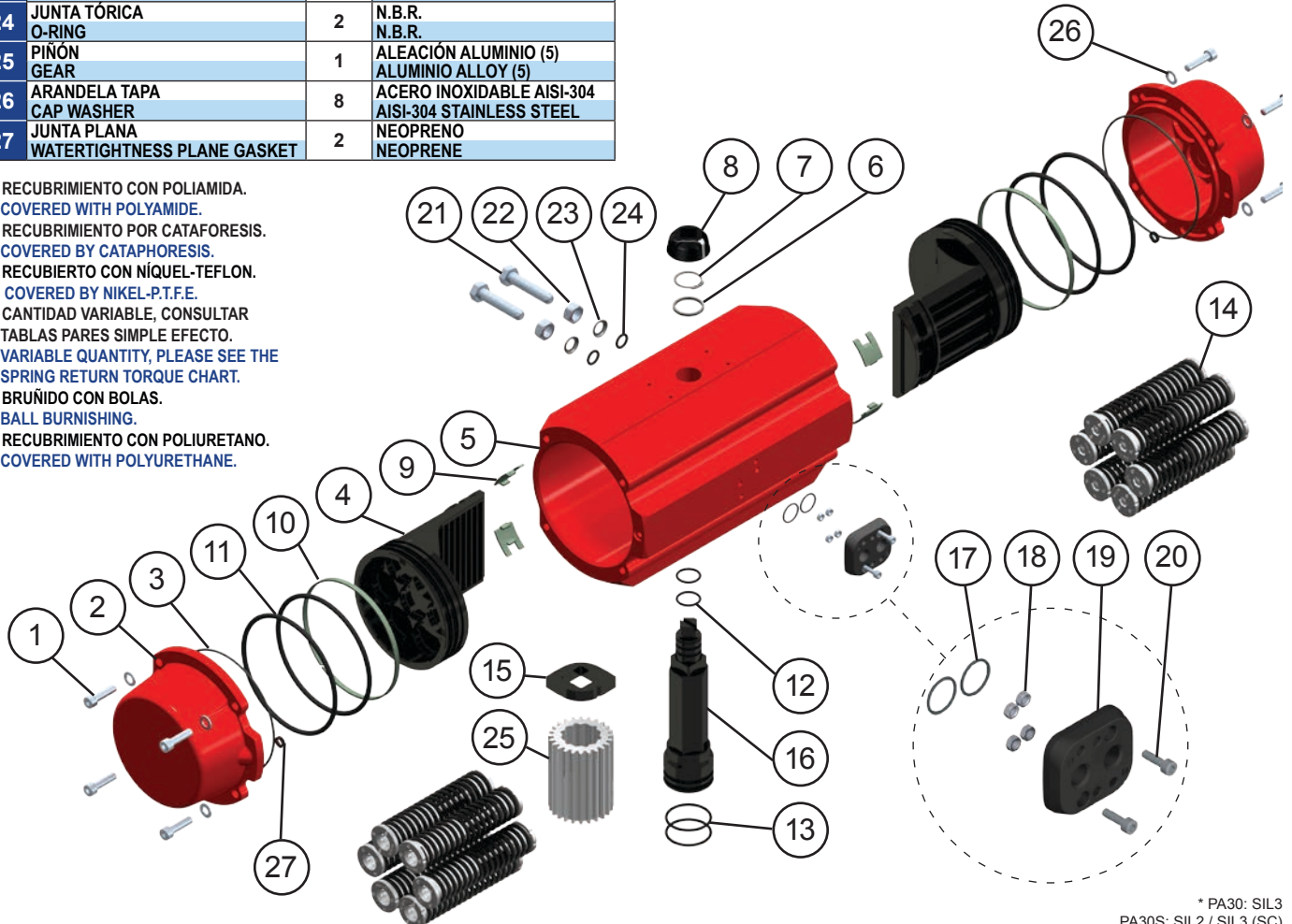

* PA30: SIL3
PA30S: SIL2 / SIL3 (SC)

MODELOS MODELS	TIEMPO DE MANIOBRA EN SEG. CYCLE TIME IN SECS.		PESOS WEIGHTS		CAPACIDAD EN LITROS CAPACITY IN LITRES	
	PARA ABRIR TO OPEN	PARA CERRAR TO CLOSE	Kg.	Lb.	PARA ABRIR TO OPEN	PARA CERRAR TO CLOSE
PA30	1,2	1,2	11,6	25,46	2,05	3
PA30S	2	2	15,3	33,64	2,05	

Tiempo de maniobra sin par resistente a 6 bar.
Cycle time w/o resistant torque at 6 bar.

Dimensiones en mm.
Dimensions in mm.

Para calcular el consumo, multiplicar las cifras del cuadro por la presión real de trabajo.

To calculate the consumption, multiply the above figures by the real working pressure.

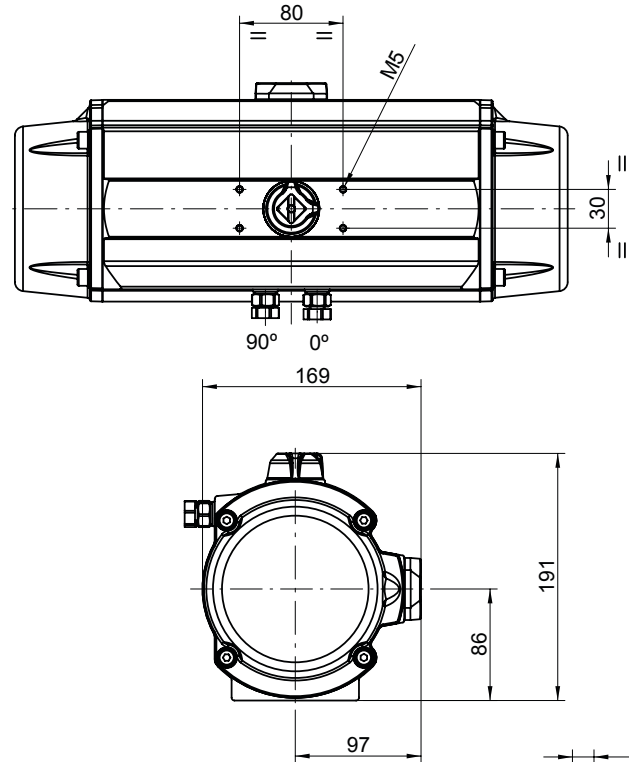
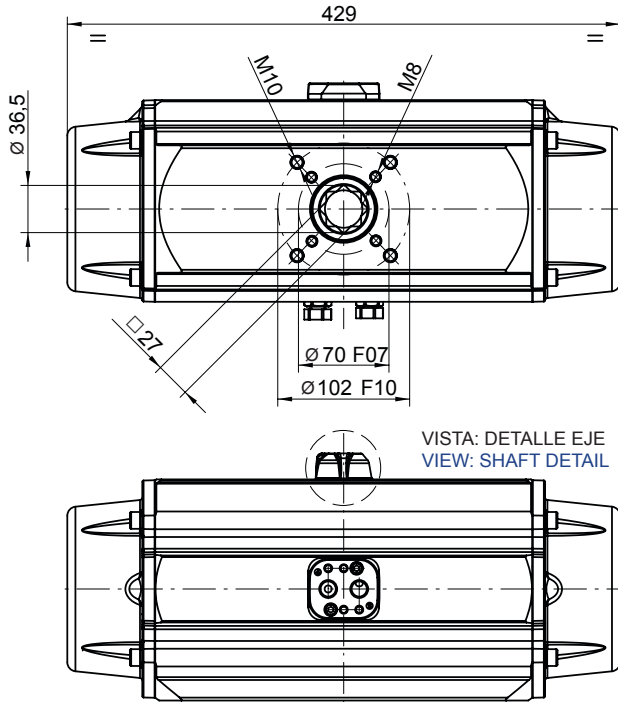

PARES DOBLE EFECTO DOUBLE ACTING TORQUES

PA30	PRESION AIRE AIR PRESSURE							
bar	3	4	4,5	5	5,5	6	7	8
p.s.i	43,5	58	65,3	72,5	79,8	87	101,5	116
Nm	226,5	307,4	347,7	388	428,7	469	550,1	631
Lb.in	2.005	2.721	3.079	3.437	3.794	4.153	4.869	5.585

PARES SIMPLE EFECTO SPRING RETURN TORQUES

PA30S	PAR MUELLES SPRING TORQUES		PAR A LA PRESIÓN INDICADA AIR TORQUE AT INDICATED PRESSURE																
			3		4		4,5		5		5,5		6		7		8		bar
N	INICIAL INITIAL	FINAL END	INICIAL INITIAL	FINAL END	INICIAL INITIAL	FINAL END	INICIAL INITIAL	FINAL END	INICIAL INITIAL	FINAL END	INICIAL INITIAL	FINAL END	INICIAL INITIAL	FINAL END	INICIAL INITIAL	FINAL END	INICIAL INITIAL	FINAL END	p.s.i
6*	290,3	195,7					152	57,4	192,6	98	233	138,4	273,5	178,9	354,4	259,8	435,3	340,7	Nm
	2.569	1.732					1.347	510	1.705	867,4	2.062	1.225	2.421	1.583	3.137	2.299	3.853	3.015	Lb.in
5	241,9	163,1			144,2	65,4	184,6	105,8	225,1	146,2	265,5	186,7	306	227,1	386,8	308	467,7	388,8	Nm
	2141	1443			1.276	579	1.636	938	1.992	1.294	2.350	1.652	2.708	2.010	3.423	2.726	4.139	3.441	Lb.in
4	193,5	130,5	96,0	32,9	176,8	113,8	217,2	154,2	257,7	194,6	298,1	235,1	338,6	275,5	419,4	356,4	500,3	437,2	Nm
	1713	1155	849,3	291	1.565	1.007	1.924	1.366	2.281	1.722	2.639	2.080	2.996	2.438	3.712	3.154	4.428	3.870	Lb.in
3	145,2	97,9	128,6	81,3	209,5	162,1	249,8	202,5	290,3	243	330,8	283,4	371,2	323,9	452,1	404,8			Nm
	1285	866	1.138	719	1.854	1.435	2.213	1.794	2.569	2.151	2.927	2.509	3.285	2.866	4.001	3.582			Lb.in
2	96,8	65,2	161,2	129,7	242,1	210,5	282,5	250,9	322,9	291,4	363,4	331,8	403,8	372,3					Nm
	856,4	577,3	1.427	1.147	2.142	1.863	2.502	2.223	2.858	2.579	3.216	2.937	3.574	3.295					Lb.in

N: Número de muelles por banda
Number of springs per side

* Número de muelles estándar
* Standard number of springs

Datos sujetos a modificación
Values could change

NORMA NAMUR E.V
SOLENOID NAMUR NORM

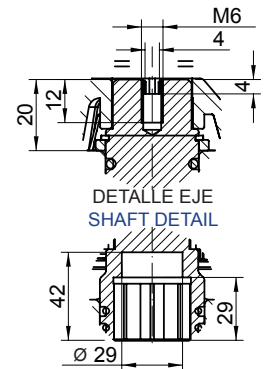
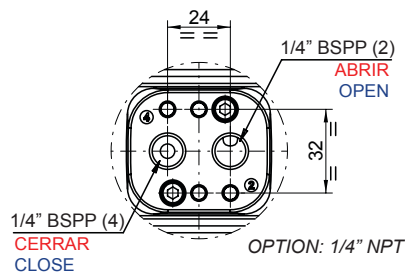

DESPIECE

DISASSEMBLY

Nº	Descripción Description	Cant. Quant.	Material Material
1	TORNILLO ALLEN TAPA CAP ALLEN SCREW	8	ACERO INOXIDABLE AISI-304 AISI-304 STAINLESS STEEL
2	TAPA DOBLE EFECTO DOUBLE ACTING CAP	2	ALEACIÓN ALUMINIO (2) + (1) ALUMINIUM ALLOY (2) + (1)
3	JUNTA TÓRICA TAPA CAP-O-RING	2	N.B.R. N.B.R.
4	ÉMBOLO PISTON	2	ALEACIÓN ALUMINIO (2) ALUMINIUM ALLOY (2)
5	CILINDRO CYLINDER	1	ALEACIÓN ALUMINIO (2) + (1) ALUMINIUM ALLOY (2) + (1)
6	ARANDELA WASHER	1	POLIAMIDA 6 POLYAMIDE 6
7	ANILLO DE SEGURIDAD SPRING CLIP	1	ACERO (2) STEEL (2)
8	INDICADOR VISUAL POSITION INDICATOR	1	POLIAMIDA POLYAMIDE
9	GUIA ÉMBOLO PISTON GUIDE	4	POLIACETAL POLYACETAL
10	ANILLO GUIA GUIDE RING	2	P.T.F.E + BRONCE P.T.F.E + BRONZE
11	JUNTA TÓRICA ÉMBOLO PISTON O-RING	4	N.B.R. N.B.R.
12	JUNTA TÓRICA EJE SHAFT O-RING	2	N.B.R. N.B.R.
13	JUNTA TÓRICA EJE SHAFT O-RING	2	N.B.R. N.B.R.
14	JUEGO DE MUELLES SPRINGS SET	2	DIN-17223-C (2) (4) DIN-17223-C (2) (4)
15	TAPA SIMPLE EFECTO SPRING RETURN CAP	2	ALEACIÓN ALUMINIO (2) + (1) ALUMINIUM ALLOY (2) + (1)
16	EJE SHAFT	1	ACERO (2) STEEL (2)
17	PIÑÓN GEAR	2	ALEACIÓN DE ALUMINIO (5) ALUMINIUM ALLOY (5)
19	JUNTA PLANA WATERTIGHTNESS PLANE GASKET	2	NEOPRENO NEOPRENE



ACTUADOR NEUMÁTICO DE ALUMINIO
ALUMINIUM PNEUMATIC ACTUATOR



P40: Doble Efecto / Double Acting

P40S: Simple Efecto / Spring Return

- (1) RECUBRIMIENTO CON POLIAMIDA.
COVERED WITH POLYAMIDE.
- (2) RECUBRIMIENTO POR CATAFORESIS.
COVERED BY CATHAPHORESIS.
- (4) CANTIDAD VARIABLE, CONSULTAR
TABLAS PARES SIMPLE EFECTO.
VARIABLE QUANTITY, PLEASE SEE THE
SPRING RETURN TORQUE CHART.
- (5) BRUÑIDO CON BOLAS.
BALL BURNISHING.

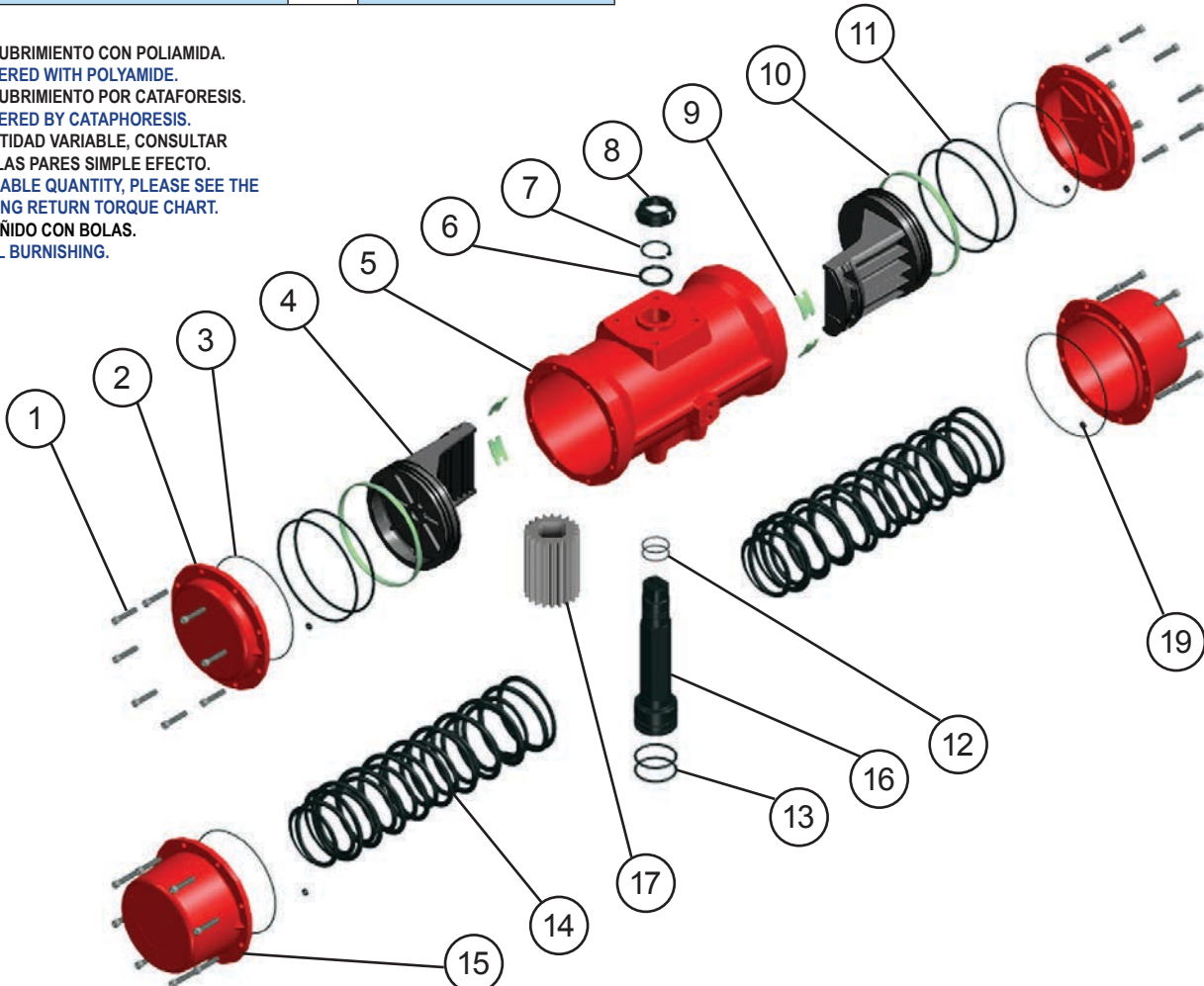

* P40: SIL3
P40S: SIL2 / SIL3 (SC)

MODELOS MODELS	TIEMPO DE MANIOBRA EN SEG. CYCLE TIME IN SECS.		PESOS WEIGHTS		CAPACIDAD EN LITROS CAPACITY IN LITRES	
	PARA ABRIR TO OPEN	PARA CERRAR TO CLOSE	Kg.	Lb.	PARA ABRIR TO OPEN	PARA CERRAR TO CLOSE
P40	1,2	1,2	17,6	38,8	5,3	5,3
P40S	2	2	36,4	80,2	5,3	

Tiempo de maniobra sin par resistente a 6 bar.
Cycle time w/o resistant torque at 6 bar.

Dimensiones en mm.
Dimensions in mm.

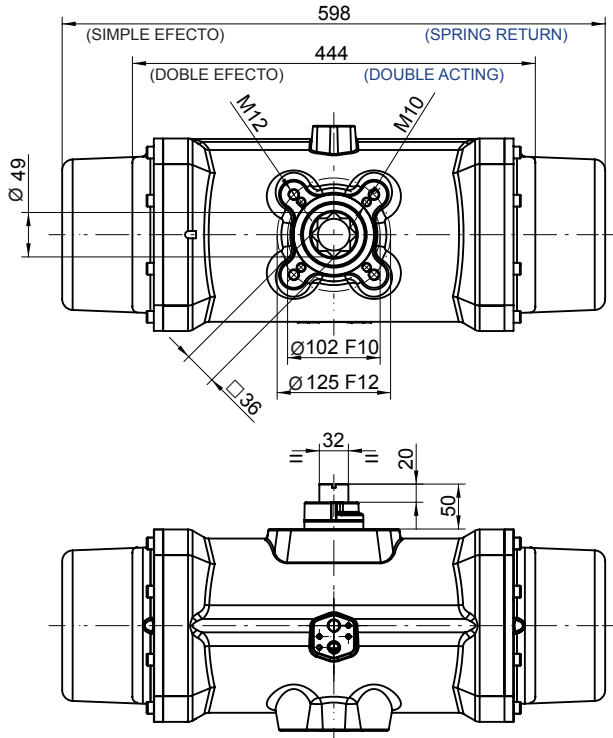

Para calcular el consumo, multiplicar las cifras del cuadro por la presión real de trabajo.

To calculate the consumption, multiply the above figures by the real working pressure.

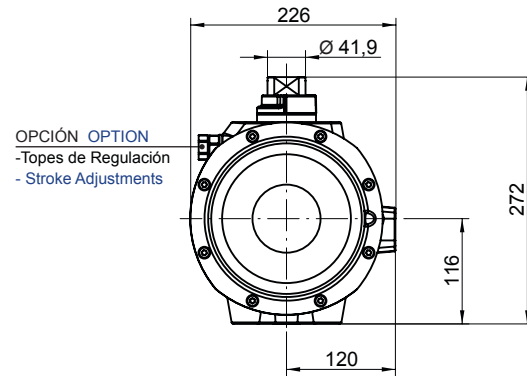
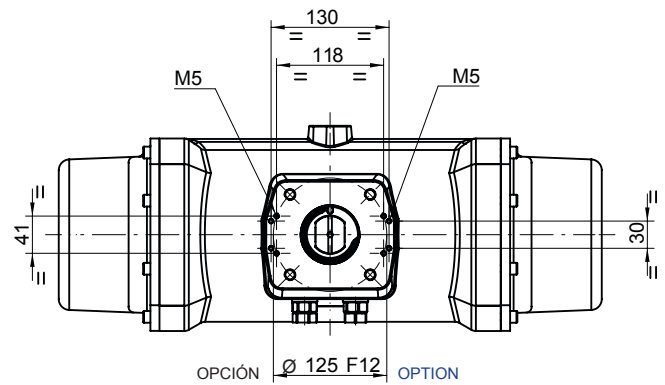

OPCIÓN OPTION
-Topes de Regulación
-Stroke Adjustments

PARES DOBLE EFECTO DOUBLE ACTING TORQUES

P40	PRESION AIRE AIR PRESSURE								
	bar	3	4	4,5	5	5,5	6	7	8
p.s.i	43,5	58	65,3	72,5	79,8	87	101,5	116	
Nm	582,5	782	881,4	980,8	1.080	1.180	1.379	1.578	
Lb.in	5.155	6.921	7.801	8.680	9.560	10.442	12.204	13.967	

NORMA NAMUR E.V
SOLENOID NAMUR NORM

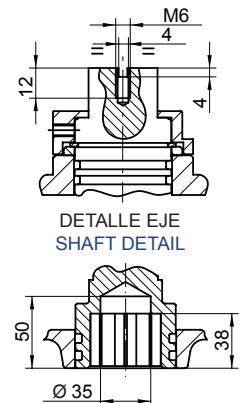
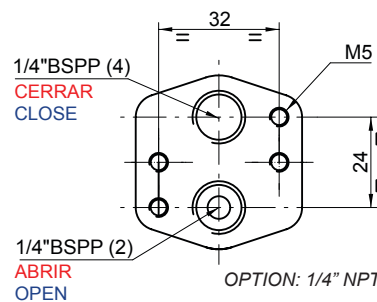

PARES SIMPLE EFECTO SPRING RETURN TORQUES

P40S	PAR MUELLES SPRING TORQUES		PAR A LA PRESIÓN INDICADA AIR TORQUE AT INDICATED PRESSURE																
			3		4		4,5		5		5,5		6		7		8		bar
	INICIAL INITIAL	FINAL END	43,5	58	65,3	72,5	79,8	87	101,5	116	p.s.i								
N	INICIAL	FINAL	INICIAL	FINAL	INICIAL	FINAL	INICIAL	FINAL	INICIAL	FINAL	INICIAL	FINAL	INICIAL	FINAL	INICIAL	FINAL	INICIAL	FINAL	
	INITIAL	END	INITIAL	END	INITIAL	END	INITIAL	END	INITIAL	END	INITIAL	END	INITIAL	END	INITIAL	END	INITIAL	END	
4*	766,9	491,6					389,8	114,5	489,1	213,8	588,4	313,4	688,3	413	887,4	612,1	1.087	811,3	Nm
	6.787	4.351					3.450	1.014	4.329	1.892	5.207	2.773	6.091	3.655	7.854	5.417	9.616	7.180	Lb.in
3	629,3	432,6			349,4	152,7	448,8	252,1	548,1	351,5	647,7	451,1	747,3	550,6	946,4	749,8	1.146	948,9	Nm
	5.569	3.829			3.092	1.352	3.972	2.232	4.851	3.111	5.732	3.992	6.613	4.873	8.376	6.635	10.138	8.398	Lb.in
2	452,3	314,6	267,9	130,2	467,4	329,7	566,8	429,1	666,1	528,5	765,7	628,1	865,3	727,6	1.064	926,8			Nm
	4.003	2.785	2.370	1.152	4.136	2.918	5.016	3.798	5.895	4.677	6.776	5.558	7.658	6.439	9.420	8.202			Lb.in
1	275,3	177	405,5	307,2	605	506,7	704,4	606,1	803,8	705,5	903,4	805,1	1.003	904,6					Nm
	2.436	1.566	3.589	2.718	5.355	4.485	6.235	5.365	7.113	6.243	7.995	7.125	8.876	8.006					Lb.in

N: Número de muelles por banda
Number of springs per side

* Número de muelles estándar
* Standard number of springs

OPCIÓN: Incorporación Sistema Seguridad Muelles
OPTION: Spring Security System Incorporated

DESPIECE

DISASSEMBLY

Nº	Descripción Description	Cant. Quant.	Material Material
1	TORNILLO ALLEN ALLEN SCREW	12	ACERO INOXIDABLE AISI-304 AISI-304 STAINLESS STEEL
2	TAPA CAP	2	ALEACIÓN ALUMINIO (2) + (1) ALUMINIUM ALLOY (2) + (1)
3	JUNTA TÓRICA TAPA CAP-O-RING	2	N.B.R. N.B.R.
4	EMBOLO PISTON	2	ALEACIÓN ALUMINIO (2) ALUMINIUM ALLOY (2)
5	CILINDRO CYLINDER	1	ALEACIÓN ALUMINIO (2) + (1) ALUMINIUM ALLOY (2) + (1)
6	ARANDELA WASHER	1	POLIAMIDA 6 POLYAMIDA 6
7	ANILLO DE SEGURIDAD SPRING CLIP	1	ACERO (2) STEEL (2)
8	INDICADOR VISUAL POSITION INDICATOR	1	POLIAMIDA POLYAMIDE
9	GUIA EMBOLO PISTON GUIDE	4	P.T.F.E + CARBONO P.T.F.E + CARBON
10	ANILLO GUIA GUIDE RING	2	P.T.F.E + BRONCE P.T.F.E + BRONZE
11	JUNTA TÓRICA ÉMBOLO PISTON O-RING	4	N.B.R. N.B.R.
12	JUNTA TÓRICA EJE SHAFT O-RING	2	N.B.R. N.B.R.
13	JUNTA TÓRICA EJE SHAFT O-RING	2	N.B.R. N.B.R.
14	MUELLES PRECARGADOS PRELOADED SPRINGS	12	DIN-17223-C (2) (4) DIN-17223-C (2) (4)
15	LEVA CAM	1	ACERO (2) STEEL (2)
16	EJE SHAFT	1	ACERO (2) STEEL (2)
17	JUNTA TÓRICA PLACA PLATE O-RING	2	N.B.R. N.B.R.
18	JUNTA TÓRICA TAPA CAP O-RING	2	N.B.R. N.B.R.
19	PLACA CONEXIÓN NEUMÁTICA PNEUMATIC CONNECTION PLATE	1	ACERO INOXIDABLE CF8M CF8M STAINLESS STEEL
20	TORNILLO ALLEN PLACA PLATE ALLEN SCREW	2	ACERO INOXIDABLE AISI-304 AISI-304 STAINLESS STEEL
21	TORNILLO HEXAGONAL HEXAGONAL SCREW	2	ACERO INOXIDABLE AISI-304 AISI-304 STAINLESS STEEL
22	TUERCA NUT	2	ACERO INOXIDABLE AISI-304 AISI-304 STAINLESS STEEL
23	ARANDELA BUSHING	2	ACERO INOXIDABLE AISI-303 AISI-303 STAINLESS STEEL
24	JUNTA TÓRICA O-RING	2	N.B.R. N.B.R.
25	PINÓN GEAR	1	ALEACION DE ALUMINIO (5) ALUMINIUM ALLOY (5)
26	ARANDELA WASHER	12	ACERO INOXIDABLE AISI-304 AISI-304 STAINLESS STEEL
27	ARGOLLA HOP	2	ACERO INOXIDABLE AISI-304 AISI-304 STAINLESS STEEL
28	CASQUILLO CAP	1	POLIACETAL POLYCETAL

- (1) RECUBRIMIENTO CON POLIAMIDA.
COVERED WITH POLYAMIDE.
- (2) RECUBRIMIENTO POR CATAFORESIS.
COVERED BY CATAPHORESIS.
- (4) CANTIDAD VARIABLE, CONSULTAR
TABLAS PARES SIMPLE EFECTO.
VARIABLE QUANTITY, PLEASE SEE THE
SPRING RETURN TORQUE CHART.
- (5) BRUÑIDO CON BOLSAS.
BALL BURNISHING.

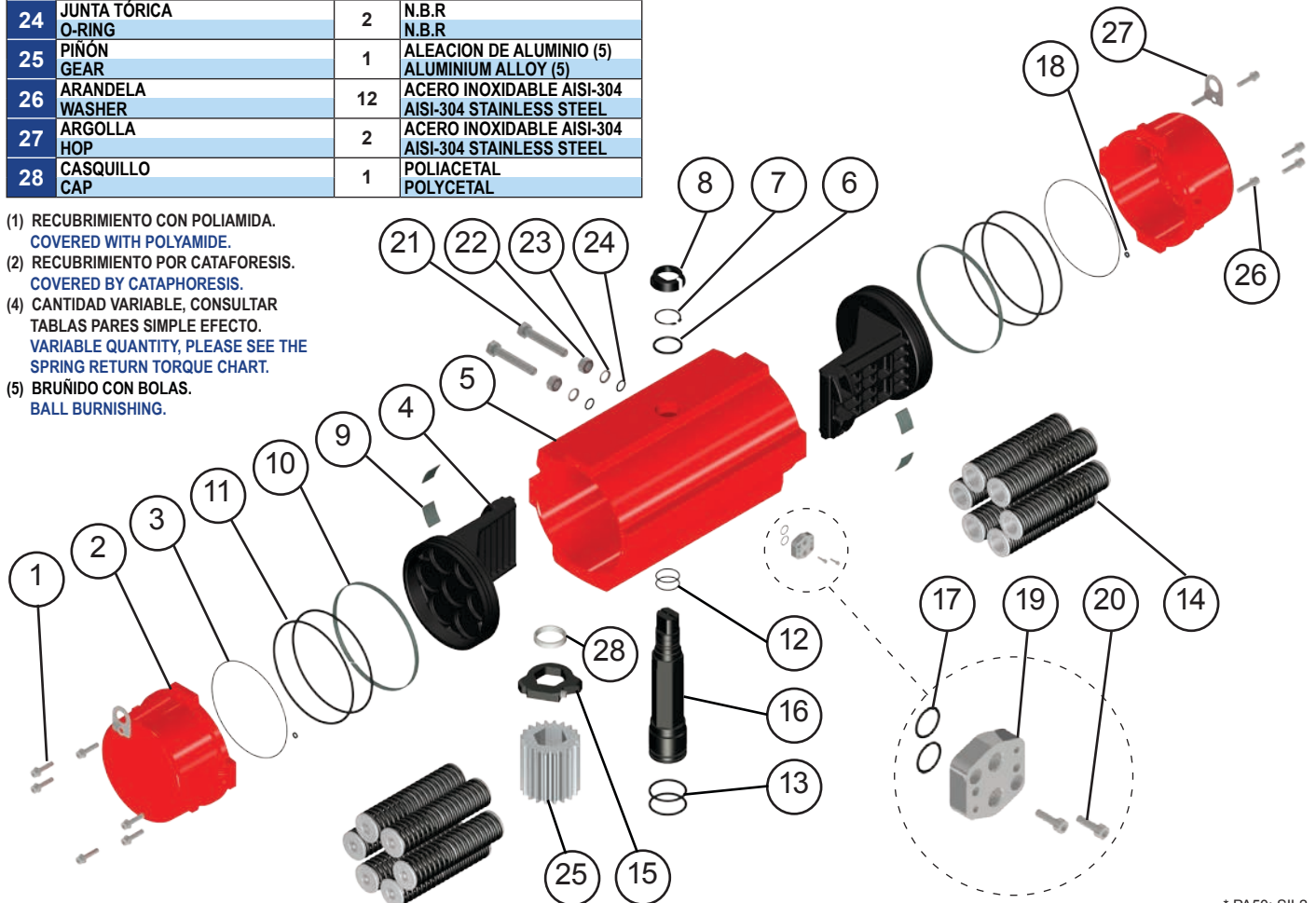

ACTUADOR NEUMÁTICO DE ALUMINIO
ALUMINIUM PNEUMATIC ACTUATOR

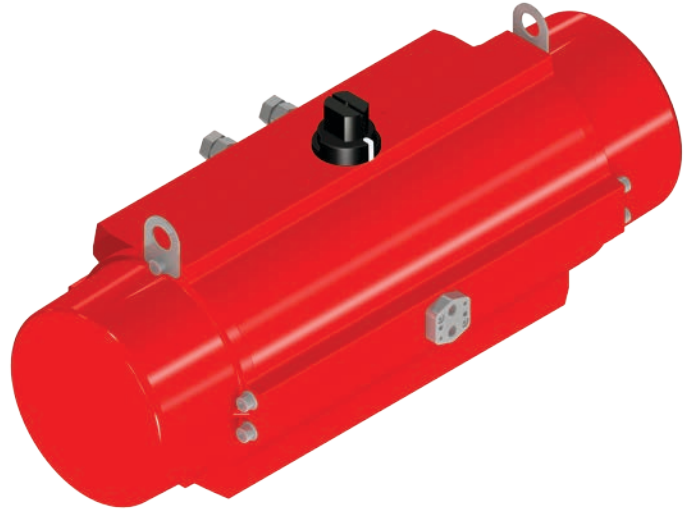

PA50: Doble Efecto / Double Acting

PA50S: Simple Efecto / Spring Return

* PA50: SIL2
PA50S: SIL2 / SIL3 (SC)

MODELOS MODELS	TIEMPO DE MANIOBRA EN SEG. CYCLE TIME IN SECS.		PESOS WEIGHTS		CAPACIDAD EN LITROS CAPACITY IN LITRES	
	PARA ABRIR TO OPEN	PARA CERRAR TO CLOSE	Kg.	Lb.	PARA ABRIR TO OPEN	PARA CERRAR TO CLOSE
PA50	3	2,5	35	77,2	10,5	14,1
PA50S	3,7	2,9	53	116,9	10,5	

Tiempo de maniobra sin par resistente a 6 bar.
Cycle time w/o resistant torque at 6 bar.

Dimensiones en mm.
Dimensions in mm.

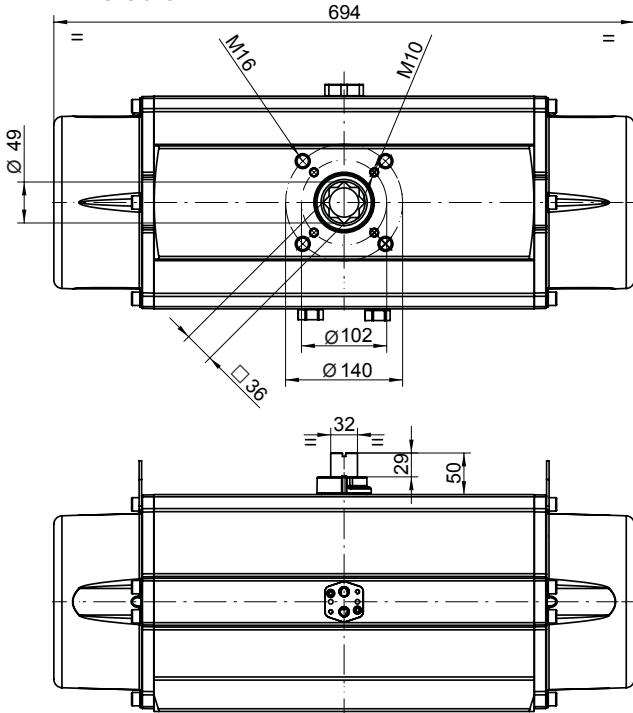

Para calcular el consumo, multiplicar las cifras del cuadro por la presión real de trabajo.

To calculate the consumption, multiply the above figures by the real working pressure.

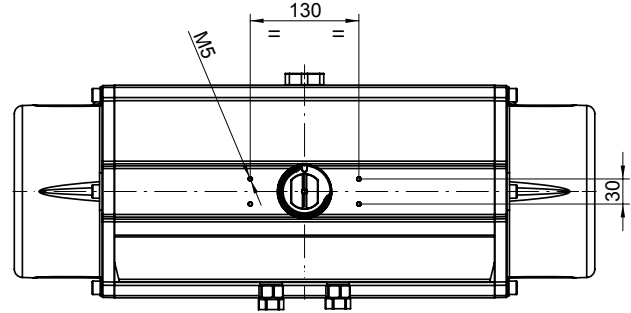

PARES DOBLE EFECTO DOUBLE ACTING TORQUES

PA50	PRESION AIRE AIR PRESSURE							
bar	3	4	4,5	5	5,5	6	7	8
p.s.i	43,5	58	65,3	72,5	79,8	87	101,5	116
Nm	998	1.354	1.532	1.711	1.889	2.067	2.424	2.780
Lb.in	8.833	11.987	13.564	15.142	16.721	18.296	21.451	24.605

PARES SIMPLE EFECTO SPRING RETURN TORQUES

PA50S	PAR MUELLES SPRING TORQUES		PAR A LA PRESIÓN INDICADA										AIR TORQUE AT INDICATED PRESSURE						bar p.s.i
			3		4		4,5		5		5,5		6		7		8		
			43,5	58	65,3	72,5	79,8	87	101,5	116									
N	INICIAL INITIAL	FINAL END	INICIAL INITIAL	FINAL END	INICIAL INITIAL	FINAL END	INICIAL INITIAL	FINAL END	INICIAL INITIAL	FINAL END	INICIAL INITIAL	FINAL END	INICIAL INITIAL	FINAL END	INICIAL INITIAL	FINAL END	INICIAL INITIAL	FINAL END	
7**	1.663 14.718	956,1 8.462									932,9 8.256	226 2.000	1.111 9.831	404 3.575	1.468 12.990	761 6.734	1.824 16.141	1.117 9.885	Nm Lb.in
6*	1.425 12.614	819,5 7.253					712,5 6.306	107 944,3	891,5 7.890	286 2.528	1.070 9.465	464 4.104	1.248 11.040	642 5.679	1.605 14.200	999 8.838	1.961 17.350	1.355 11.989	Nm Lb.in
5	1.187 10.511	682,9 6.044			671,1 5.939	167 1.472	849,1 7.515	345 3.047	1.028 9.099	524 4.631	1.206 10.674	702 6.207	1.384 12.249	880 7.782	1.741 15.409	1.237 10.941	2.097 18.559	1.593 14.092	Nm Lb.in
4	989,7 8.759	569,1 5.037			784,9 6.946	364,3 3.224	962,9 8.522	542,3 4.799	1.142 10.106	721,3 6.384	1.320 11.681	899,3 7.959	1.498 13.256	1.077 9.534	1.855 16.416	1.434 12.694	2.211 19.566	1.790 15.844	Nm Lb.in
3	824,8 7.299	474,2 4.197	523,8 4.636	173,2 1.533	879,8 7.786	529,2 4.683	1.058 9.362	707,2 6.259	1.237 10.946	886,2 7.843	1.415 12.521	1.064 9.418	1.593 14.096	1.242 10.993	1.950 17.256	1.599 14.153	2.306 20.406	1.955 17.304	Nm Lb.in
2	687,3 6.083	395,2 3.498	602,8 5.335	310,7 2.750	958,8 8.485	666,7 5.900	1.137 10.061	844,7 7.476	1.316 11.645	1.024 9.060	1.494 13.220	1.202 10.635	1.672 14.795	1.380 12.210	2.029 17.955	1.737 15.370	2.385 21.105	2.093 18.520	Nm Lb.in

N: Número de muelles por banda
Number of springs per side

* Número de muelles estándar
* Standard number of springs

** Opcional (bajo pedido)
** Optional (on request)

NORMA NAMUR E.V
SOLENOID NAMUR NORM

1/4"BSPP (4)
CERRAR
CLOSE

1/4"BSPP (2)
ABRIR
OPEN

OPTION: 1/4" NPT

DETALLE EJE
SHAFT DETAIL

DESPIECE

DISASSEMBLY



Nº	Descripción Description	Cant. Quant.	Material Material
1	TORNILLO ALLEN TAPA CAP ALLEN SCREW	16	ACERO INOXIDABLE AISI-304 AISI-304 STAINLESS STEEL
2	TAPA CAP	2	ALEACIÓN ALUMINIO (2) + (1) ALUMINIUM ALLOY (2) + (1)
3	JUNTA TÓRICA TAPA CAP-O-RING	2	N.B.R. N.B.R.
4	ÉMBOLO PISTON	2	ALEACIÓN ALUMINIO ALUMINIUM ALLOY
5	CILINDRO CYLINDER	1	ALEACIÓN ALUMINIO (2) + (1) ALUMINIUM ALLOY (2) + (1)
6	ARANDELA WASHER	1	POLIAMIDA 6 POLYAMIDA 6
7	ANILLO DE SEGURIDAD SPRING CLIP	1	ACERO (2) STEEL (2)
8	INDICADOR VISUAL POSITION INDICATOR	1	POLIAMIDA POLYAMIDE
9	GUIA ÉMBOLO PISTON GUIDE	4	P.F.T.E + CARBONO P.F.T.E + CARBON
10	ANILLO GUIA GUIDE RING	2	P.T.F.E + BRONCE P.T.F.E + BRONZE
11	JUNTA TÓRICA ÉMBOLO PISTON O-RING	4	N.B.R. N.B.R.
12	JUNTA TÓRICA EJE SHAFT O-RING	2	N.B.R. N.B.R.
13	JUNTA TÓRICA EJE SHAFT O-RING	2	N.B.R. N.B.R.
14	MUELLES PRECARGADOS PRELOADED SPRINGS	12	DIN-17223-C (2) (4) DIN-17223-C (2) (4)
15	LEVA CAM	1	ACERO (2) STEEL (2)
16	EJE SHAFT	1	ACERO (2) STEEL (2)
17	JUNTA TÓRICA PLACA PLATE O-RING	2	N.B.R. N.B.R.
18	JUNTA TÓRICA TAPA CAP O-RING	2	N.B.R. N.B.R.
19	PLACA CONEXIÓN NEUMÁTICA PNEUMATIC CONNECTION PLATE	1	ACERO INOXIDABLE CF8M CF8M STAINLESS STEEL
20	TORNILLO ALLEN PLACA PLATE ALLEN SCREW	2	ACERO INOXIDABLE AISI-304 AISI-304 STAINLESS STEEL
21	TORNILLO HEXAGONAL HEXAGONAL SCREW	2	ACERO (3) STEEL (3)
22	TUERCA NUT	2	ACERO INOX. AISI-304 AISI-304 STAINLESS STEEL
23	ARANDELA BUSHING	2	ACERO INOXIDABLE AISI-303 AISI-303 STAINLESS STEEL
24	JUNTA TÓRICA O-RING	2	N.B.R. N.B.R.
25	PIÑÓN GEAR	1	ALEACION DE ALUMINIO (5) ALUMINIUM ALLOY (5)
26	ARANDELA WASHER	16	ACERO INOX. AISI-304 AISI-304 STAINLESS STEEL
27	ARGOLLA HOOP	2	ACERO INOX. AISI-304 AISI-304 STAINLESS STEEL

- (1) RECUBRIMIENTO CON POLIAMIDA.
COVERED WITH POLYAMIDE.
- (2) RECUBRIMIENTO POR CATAFORESIS.
COVERED BY CATAPHORESIS.
- (3) PASIVADO DE CROMO TRIVALENTE.
TRIVALENT Cr PASSIVATION.
- (4) CANTIDAD VARIABLE, CONSULTAR
TABLAS PARES SIMPLE EFECTO.
VARIABLE QUANTITY, PLEASE SEE THE
SPRING RETURN TORQUE CHART.
- (5) BRUÑIDO CON BOLAS.
BALL BURNISHING.

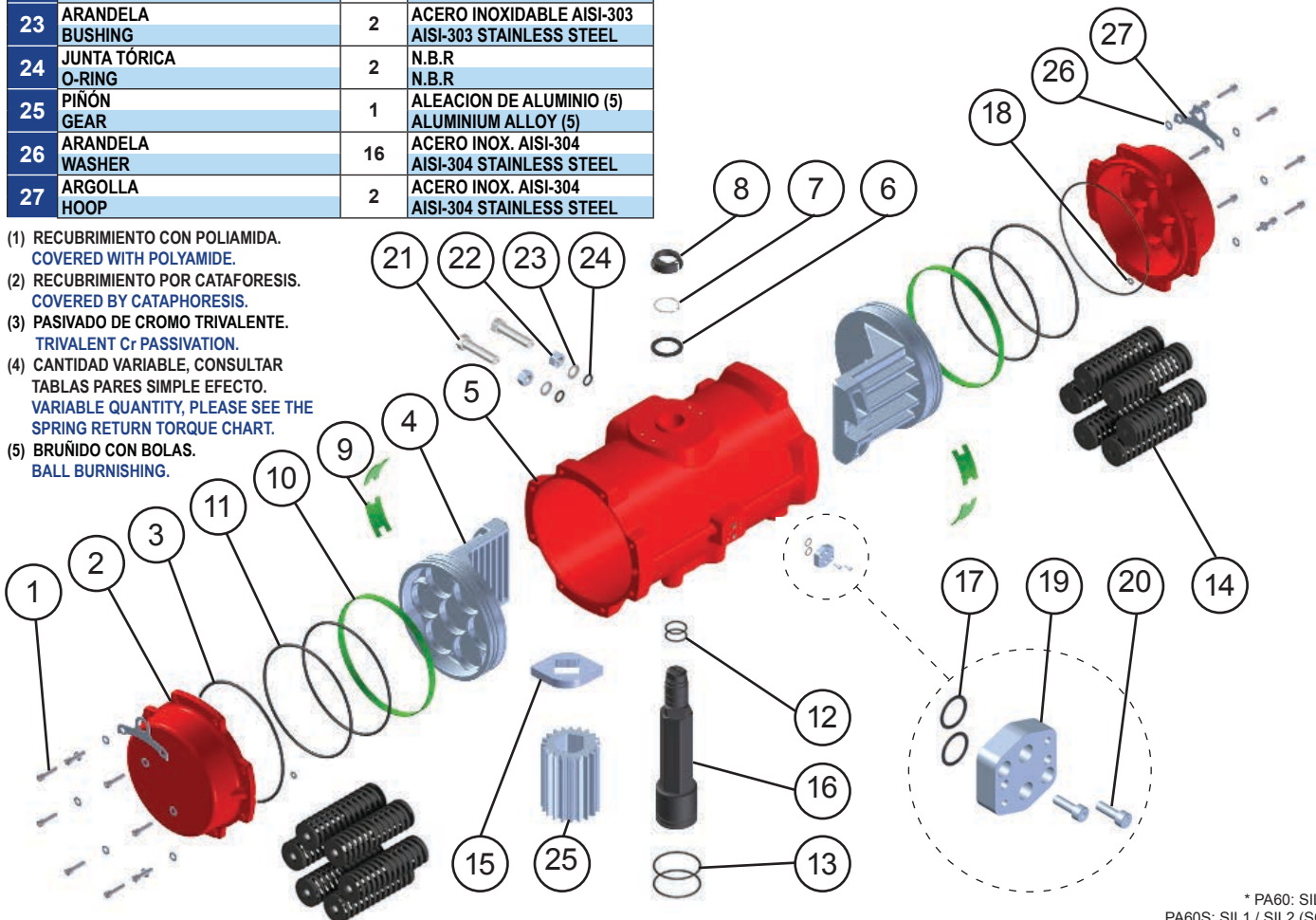

ACTUADOR NEUMÁTICO DE ALUMINIO
ALUMINIUM PNEUMATIC ACTUATOR



PA60: Doble Efecto / Double Acting

PA60S: Simple Efecto / Spring Return

* PA60: SIL2
PA60S: SIL1 / SIL2 (SC)

MODELOS MODELS	TIEMPO DE MANIOBRA EN SEG. CYCLE TIME IN SECS.		PESOS WEIGHTS		CAPACIDAD EN LITROS CAPACITY IN LITRES	
	PARA ABRIR TO OPEN	PARA CERRAR TO CLOSE	Kg.	Lb.	PARA ABRIR TO OPEN	PARA CERRAR TO CLOSE
PA60	3	3	48,3	106,48	19,5	20,7
PA60S	6	5	83,2	183,41	19,5	

Tiempo de maniobra sin par resistente a 6 bar.
Cycle time w/o resistant torque at 6 bar.

Dimensiones en mm.
Dimensions in mm.

Para calcular el consumo, multiplicar las cifras del cuadro por la presión real de trabajo.

To calculate the consumption, multiply the above figures by the real working pressure.

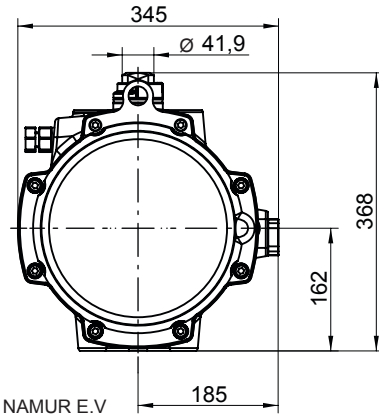
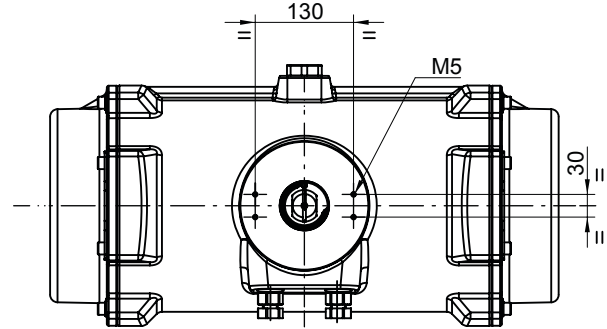
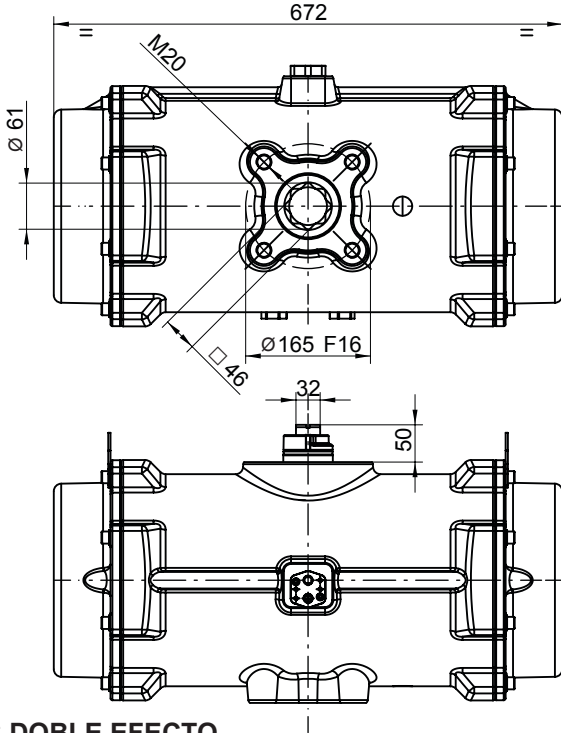

NORMA NAMUR E.V
SOLENOID NAMUR NORM

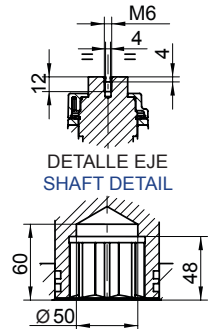
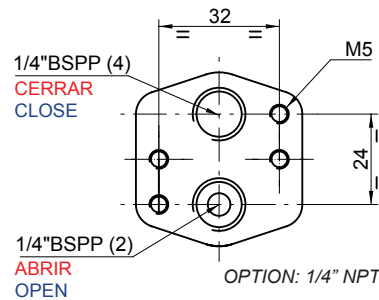

PARES DOBLE EFECTO DOUBLE ACTING TORQUES

PA60	PRESION AIRE AIR PRESSURE							
bar	3	4	4,5	5	5,5	6	7	8
p.s.i	43,5	58	65,3	72,5	79,8	87	101,5	116
Nm	1.638	2.245	2.548	2.851	3.155	3.458	4.065	4.672
Lb.in	14.497	19.870	22.551	25.233	27.924	30.606	35.978	41.351

PARES SIMPLE EFECTO SPRING RETURN TORQUES

PA60S	PAR MUELLES SPRING TORQUES		PAR A LA PRESIÓN INDICADA AIR TORQUE AT INDICATED PRESSURE																	
	INICIAL INITIAL	FINAL END	3	4	4,5	5	5,5	6	7	8	bar									
N			43,5	58	65,3	72,5	79,8	87	101,5	116	p.s.i									
6*	2.075 18.365	1.383 12.241																		
5	1.729 15.303	1.153 10.205																		
4	1.383 12.241	922 8.160																		
3	1.037 9.178	692 6.125	946 8.373	601 5.319	1.553 13.745	1.208 10.692	1.856 16.426	1.511 13.373	2.159 19.109	1.814 16.055	2.463 21.799	2.118 18.746	2.766 24.481	2.421 21.428	3.373 29.854	3.028 26.800				
2	692 6.125	462 4.089	1.176 10.408	946 8.373	1.783 15.781	1.553 13.745	2.086 18.462	1.856 16.426	2.389 21.144	2.159 19.109	2.693 23.835	2.463 21.799	2.996 24.481	2.766 24.481						

N: Número de muelles por banda
Number of springs per side

* Número de muelles estándar
* Standard number of springs

DESPIECE

DISASSEMBLY



ACTUADOR NEUMÁTICO DE ALUMINIO
ALUMINIUM PNEUMATIC ACTUATOR

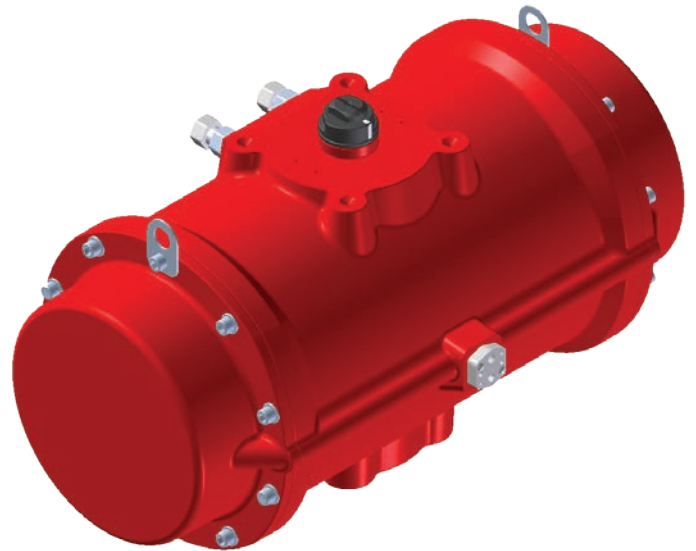

PA70: Doble Efecto / Double Acting

PA70S: Simple Efecto / Spring Return

Nº	Descripción Description	Cant. Quant.	Material Material
1	TORNILLO ALLEN ALLEN SCREW	20	ACERO INOXIDABLE AISI-304 AISI-304 STAINLESS STEEL
2	TAPA CAP	2	ALEACIÓN ALUMINIO (2) + (1) ALUMINIUM ALLOY (2) + (1)
3	JUNTA TÓRICA TAPA CAP-O-RING	2	N.B.R. N.B.R.
4	EMBOLO PISTON	2	ALEACIÓN ALUMINIO ALUMINIUM ALLOY
5	CILINDRO CYLINDER	1	ALEACIÓN ALUMINIO (2) + (1) ALUMINIUM ALLOY (2) + (1)
6	ARANDELA WASHER	1	POLIAMIDA 6 POLYAMIDA 6
7	ANILLO DE SEGURIDAD SPRING CLIP	1	ACERO (2) STEEL (2)
8	INDICADOR VISUAL POSITION INDICATOR	1	POLIAMIDA POLYAMIDE
9	GUIA ÉMBOLO PISTON GUIDE	4	NYLON NYLON
10	ANILLO GUIA GUIDE RING	2	P.T.F.E + BRONCE P.T.F.E + BRONZE
11	JUNTA TÓRICA ÉMBOLO PISTON O-RING	4	N.B.R. N.B.R.
12	JUNTA TÓRICA EJE SHAFT O-RING	2	N.B.R. N.B.R.
13	JUNTA TÓRICA EJE SHAFT O-RING	2	N.B.R. N.B.R.
14	MUELLES PRECARGADOS PRELOADED SPRINGS	12	DIN-17223-C (2) (4) DIN-17223-C (2) (4)
15	LEVA CAM	1	ACERO (2) STEEL (2)
16	EJE SHAFT	1	ACERO (2) STEEL (2)
17	JUNTA TÓRICA PLACA PLATE O-RING	2	N.B.R. N.B.R.
18	JUNTA TÓRICA TAPA CAP O-RING	2	N.B.R. N.B.R.
19	PLACA CONEXIÓN NEUMÁTICA PNEUMATIC CONNECTION PLATE	1	ACERO INOXIDABLE CF8M CF8M STAINLESS STEEL
20	TORNILLO ALLEN PLACA PLATE ALLEN SCREW	2	ACERO INOXIDABLE AISI-304 AISI-304 STAINLESS STEEL
21	TORNILLO HEXAGONAL HEXAGONAL SCREW	2	ACERO (3) STEEL (3)
22	TUERCA NUT	2	ACERO INOXIDABLE AISI-304 AISI-304 STAINLESS STEEL
23	ARANDELA BUSHING	2	ACERO INOXIDABLE AISI-303 AISI-303 STAINLESS STEEL
24	JUNTA TÓRICA O-RING	2	N.B.R. N.B.R.
25	PIÑÓN GEAR	1	ALEACION DE ALUMINIO (5) ALUMINIUM ALLOY (5)
26	ARANDELA WASHER	20	ACERO INOXIDABLE AISI-304 AISI-304 STAINLESS STEEL
27	ARGOLLA HOOP	2	ACERO INOXIDABLE AISI-304 AISI-304 STAINLESS STEEL

- (1) RECUBRIMIENTO CON POLIAMIDA.
COVERED WITH POLYAMIDE.
- (2) RECUBRIMIENTO POR CATAFORESIS.
COVERED BY CATAPHORESIS.
- (3) PASIVADO DE CROMO TRIVALENTE.
TRIVALENT Cr PASSIVATION.
- (4) CANTIDAD VARIABLE, CONSULTAR
TABLAS PARES SIMPLE EFECTO.
VARIABLE QUANTITY, PLEASE SEE THE
SPRING RETURN TORQUE CHART.
- (5) BRUÑIDO CON BOLAS.
BALL BURNISHING.

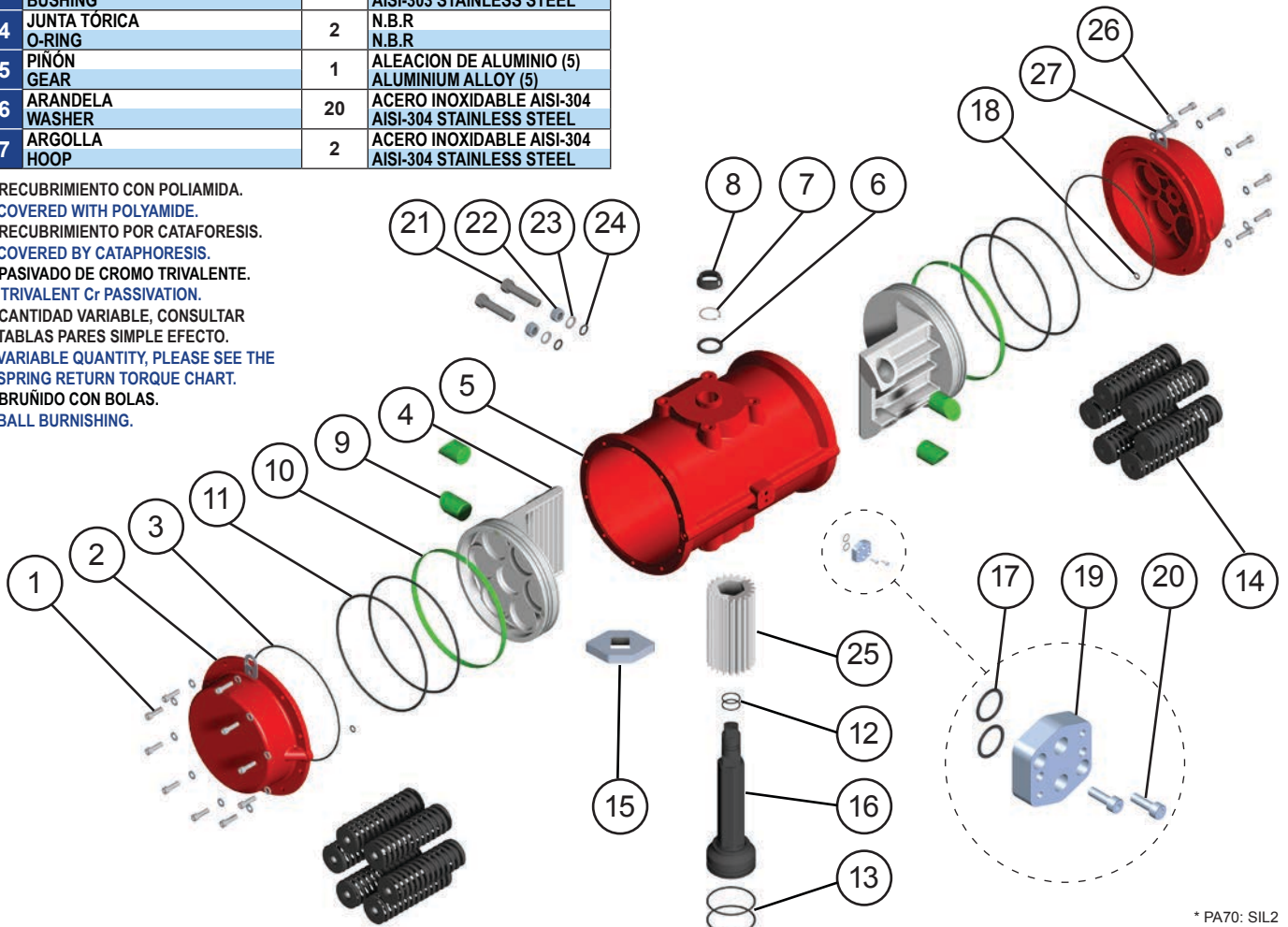

* PA70: SIL2
PA70S: SIL1 / SIL2 (SC)

MODELOS MODELS	TIEMPO DE MANIOBRA EN SEG. CYCLE TIME IN SECS.		PESOS WEIGHTS		CAPACIDAD EN LITROS CAPACITY IN LITRES	
	PARA ABRIR TO OPEN	PARA CERRAR TO CLOSE	Kg.	Lb.	PARA ABRIR TO OPEN	PARA CERRAR TO CLOSE
PA70	4	4	77,9	171,74	31	30
PA70S	8	6	118,2	260,59	31	

Tiempo de maniobra sin par resistente a 6 bar.
Cycle time w/o resistant torque at 6 bar.

Dimensiones en mm.
Dimensions in mm.

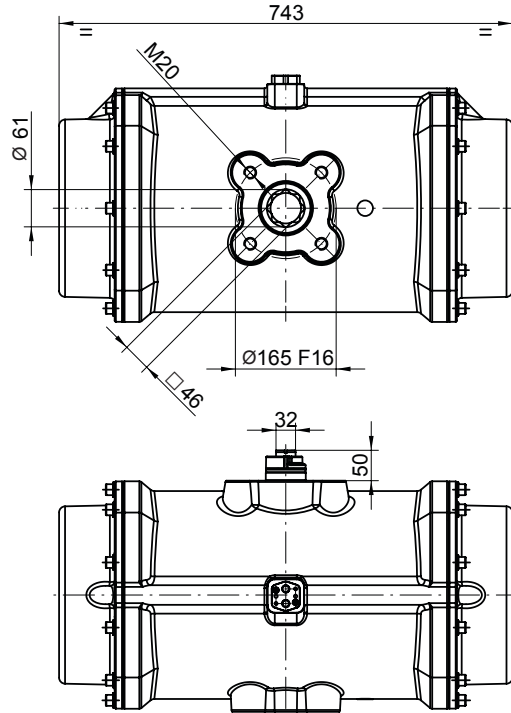

Para calcular el consumo, multiplicar las cifras del cuadro por la presión real de trabajo.

To calculate the consumption, multiply the above figures by the real working pressure.

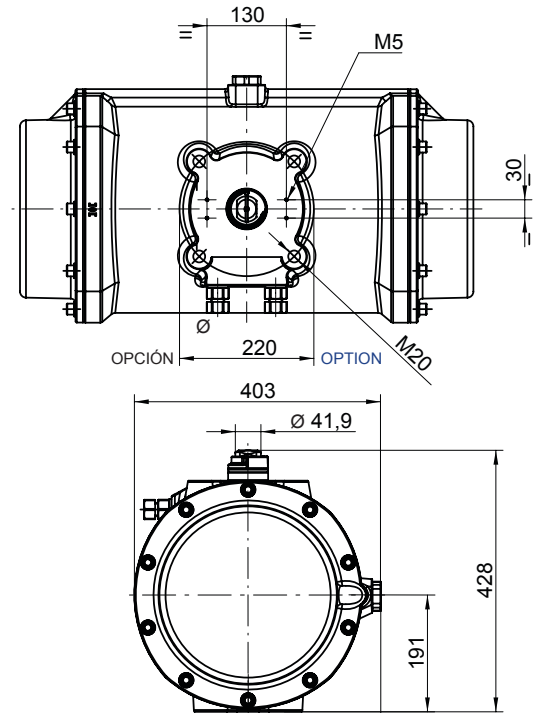

PARES DOBLE EFECTO DOUBLE ACTING TORQUES

PA70	PRESION AIRE AIR PRESSURE							
bar	3	4	4,5	5	5,5	6	7	8
p.s.i	43,5	58	65,3	72,5	79,8	87	101,5	116
Nm	2.389	3.273	3.715	4.158	4.600	5.043	5.927	6.812
Lb.in	21.141	28.971	32.886	36.801	40.716	44.631	52.461	60.291

NORMA NAMUR E.V
SOLENOID NAMUR NORM

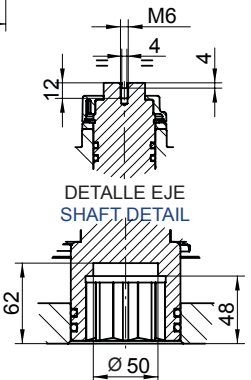
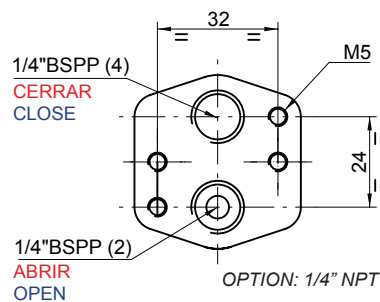

PARES SIMPLE EFECTO SPRING RETURN TORQUES

PA70S	PAR MUELLES SPRING TORQUES		PAR A LA PRESIÓN INDICADA AIR TORQUE AT INDICATED PRESSURE																	
	INICIAL INITIAL	FINAL END	3 43,5	4 58	4,5 65,3	5 72,5	5,5 79,8	6 87	7 101,5	8 116	bar		p.s.i							
N	INICIAL	FINAL	INICIAL	FINAL	INICIAL	FINAL	INICIAL	FINAL	INICIAL	FINAL	INICIAL	FINAL	INICIAL	FINAL	INICIAL	FINAL	INICIAL	FINAL		
6*	3.539	1.769							2.389	619	2.831	1.062	3.273	1.504	4.158	2.389	5.043	2.273		Nm
	31.320	15.660							21.142	5.481	25.056	9.396	28.971	13.311	36.801	21.141	44.632	28.971		Lb.in
5	2.949	1.475					2.240	766,5	2.684	1.209	3.126	1.651	3.568	2.094	4.453	2.978	5.338	3.683		Nm
	26.100	13.050					19.836	6.786	23.751	10.701	27.666	14.616	31.580	18.531	39.411	26.361	47.241	34.191		Lb.in
4	2.359	1.180			2.094	914	2.535	1.356	2.978	1.799	3.421	2.241	3.863	2.684	4.748	3.568	5.632	4.453		Nm
	20.880	10.440			18.531	8.091	22.446	12.006	26.361	15.922	30.276	19.836	34.190	23.751	42.021	31.581	49.851	39.411		Lb.in
3	1.769	885	1.504	619	2.389	1.504	2.830	1.946	3.273	2.389	3.716	2.831	4.158	3.273	5.043	4.158				Nm
	16.660	7.830	13.311	5.481	21.141	13.311	25.056	16.226	28.971	21.142	32.886	25.056	36.800	28.971	44.631	36.801				Lb.in
2	1.180	590	1.799	1.209	2.684	2.094	3.125	2.535	3.568	2.978	4.011	3.421	4.453	3.863						Nm
	10.440	5.220	15.921	10.701	23.751	18.531	27.666	22.446	31.581	26.361	35.496	30.276	39.411	34.190						Lb.in

N: Número de muelles por banda
Number of springs per side

* Número de muelles estándar
* Standard number of springs



**ACTUADORES NEUMÁTICOS DE ALUMINIO
CON GIRO DE 180°**

**ALUMINIUM PNEUMATIC ACTUATORS
180° ROTATION**

DESPIECE

DISASSEMBLY



Nº	Descripción Description	Cant. Quant.	Material Material
1	TORNILLO AVELLANADO TAPA CAP COUNTERSUNK SCREW	8	ACERO INOXIDABLE AISI-304 AISI-304 STAINLESS STEEL
2	TAPA CAP	2	ALEACIÓN ALUMINIO (2) + (7) ALUMINIUM ALLOY (2) + (7)
3	JUNTA TÓRICA TAPA CAP-O-RING	2	N.B.R. N.B.R.
4	ÉMBOLO PISTON	2	ALEACIÓN ALUMINIO (2) ALUMINIUM ALLOY (2)
5	CILINDRO CYLINDER	1	ALEACIÓN DE ALUMINIO (2) + (1) ALUMINIUM ALLOY (2) + (1)
6	ARANDELA WASHER	1	POLIACETAL POLYACETAL
7	ANILLO DE SEGURIDAD SPRING CLIP	1	ACERO INOXIDABLE STAINLESS STEEL
8	INDICADOR VISUAL POSITION INDICATOR	1	POLIACETAL POLYACETAL
9	GUIA ÉMBOLO PISTON GUIDE	2	NYLON NYLON
10	ANILLO GUIA GUIDE RING	2	POLIACETAL + Mb POLYACETAL + Mb
11	JUNTA TÓRICA ÉMBOLO PISTON O-RING	2	N.B.R. N.B.R.
12	JUNTA TÓRICA EJE SHAFT O-RING	2	N.B.R. N.B.R.
13	JUNTA TÓRICA EJE SHAFT O-RING	2	N.B.R. N.B.R.
14	JUEGO DE MUELLES SPRINGS SET	2	DIN-17223-C (2) (4) DIN-17223-C (2) (4)
15	PLACA BASE (ISO-5211) BASE PLATE (ISO-5211)	1	POLIAMIDA + FV POLYAMIDE + FG
16	EJE SHAFT	1	POLIAMIDA + INSERTO INOX. POLYAMIDE + S.S. INSERT
17	DADO DE CONEXIÓN DRIVE ADAPTER	1	ACERO INOXIDABLE AISI-316 AISI-316 STAINLESS STEEL
18	TORNILLO ALLEN ALLEN SCREW	2	ACERO INOXIDABLE AISI-304 AISI-304 STAINLESS STEEL
19	TUERCA NUT	4	ACERO INOXIDABLE AISI-304 AISI-304 STAINLESS STEEL
20	JUNTA TÓRICA PLACA PLATE O-RING	2	N.B.R. N.B.R.
21	TUERCA NUT	4	ACERO INOXIDABLE AISI-304 AISI-304 STAINLESS STEEL
22	PLACA CONEXIÓN NEUMÁTICA PNEUMATIC CONNECTION PLATE	1	POLIAMIDA + FV POLYAMIDE + FG
23	TORNILLO ALLEN PLACA PLATE ALLEN SCREW	2	ACERO INOXIDABLE AISI-304 AISI-304 STAINLESS STEEL

ACTUADOR NEUMÁTICO DE ALUMINIO
(GIRO: 180°)
ALUMINIUM PNEUMATIC ACTUATOR
(ROTATION: 180°)



PAGW: Doble Efecto / Double Acting
PAGWS: Simple Efecto / Spring Return

- (1) RECUBRIMIENTO CON POLIAMIDA.
COVERED WITH POLYAMIDE.
- (2) RECUBRIMIENTO POR CATAFORESIS.
COVERED BY CATAPHORESIS.
- (4) CANTIDAD VARIABLE, CONSULTAR TABLAS PARES SIMPLE EFECTO.
VARIABLE QUANTITY, PLEASE SEE THE SPRING RETURN TORQUE CHART.
- (7) RECUBR. CON POLIURETANO.
COVERED WITH POLYURETHANE.

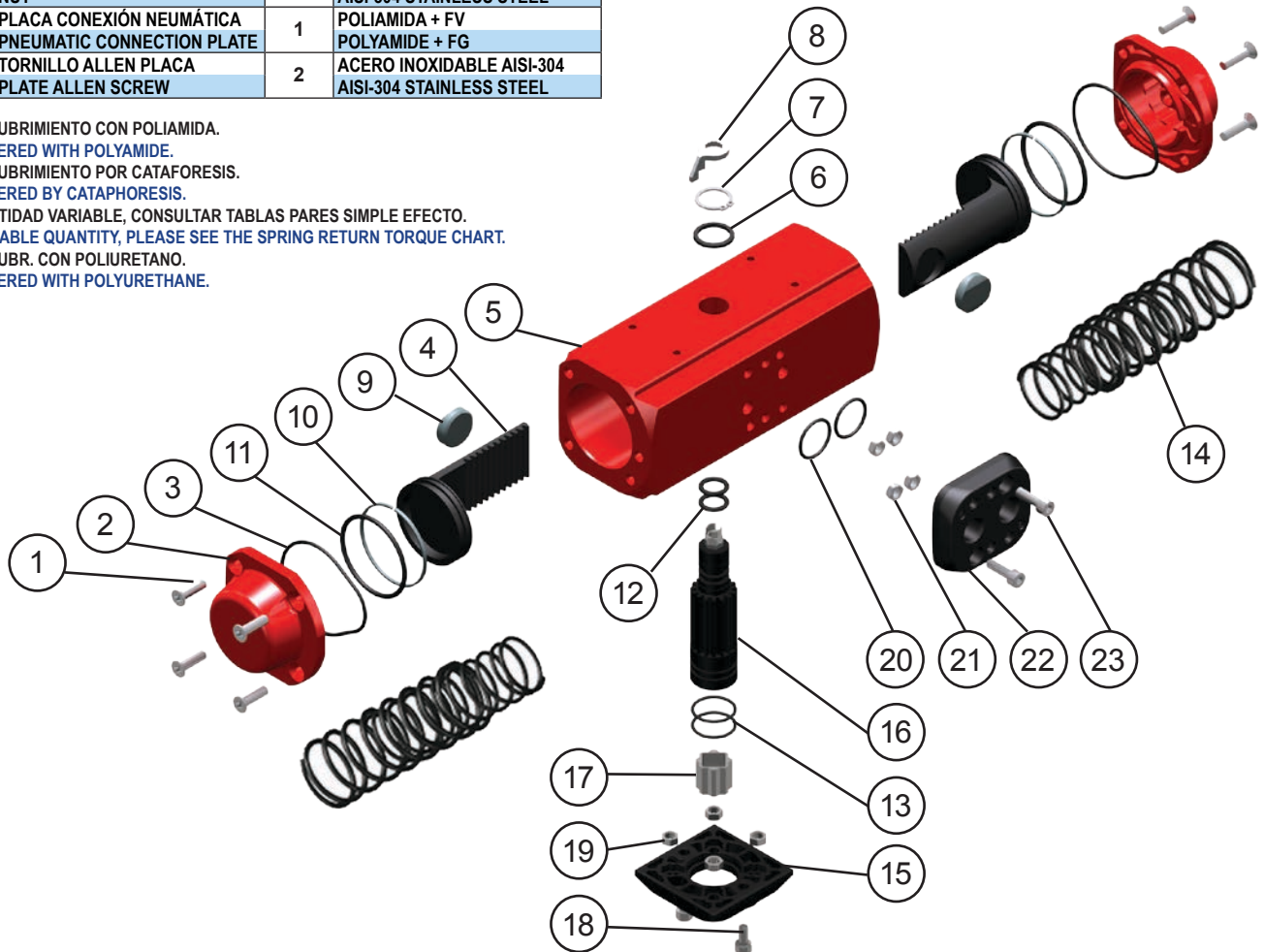

MODELOS MODELS	TIEMPO DE MANIOBRA EN SEG. CYCLE TIME IN SECS.		PESOS WEIGHTS		CAPACIDAD EN LITROS CAPACITY IN LITRES	
	PARA ABRIR TO OPEN	PARA CERRAR TO CLOSE	Kg.	Lb.	PARA ABRIR TO OPEN	PARA CERRAR TO CLOSE
PAGW	0,13	0,13	1,3	2,76	0,123	0,158
PAGWS	0,20	0,20	1,5	3,31	0,123	

Tiempo de maniobra sin par resistente a 6 bar.
Cycle time w/o resistant torque at 6 bar.

Dimensiones en mm.
Dimensions in mm.

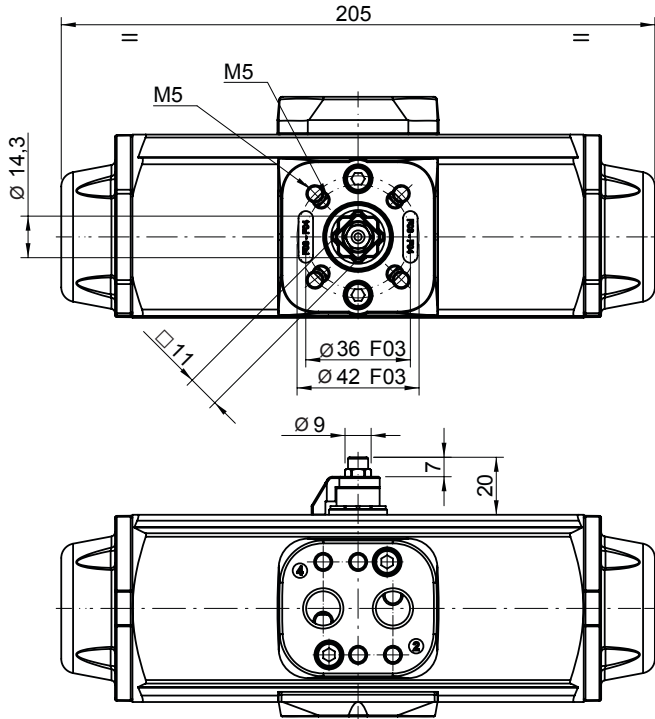

Para calcular el consumo, multiplicar las cifras del cuadro por la presión real de trabajo.

To calculate the consumption, multiply the above figures by the real working pressure.

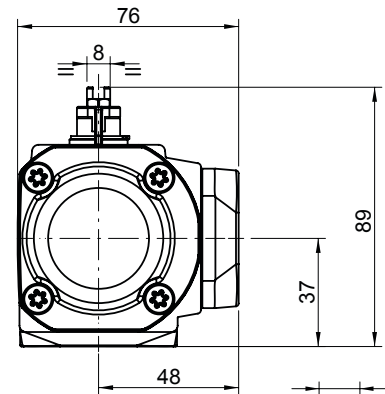
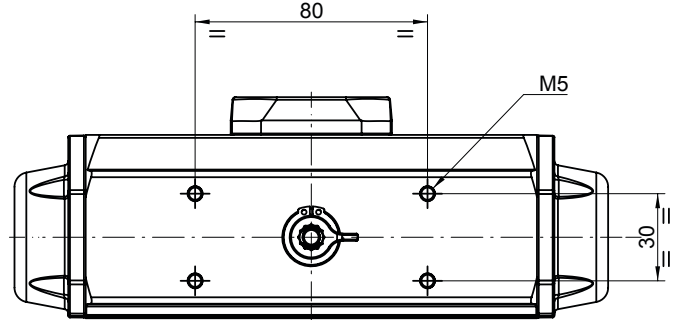

PARES DOBLE EFECTO DOUBLE ACTING TORQUES

PAGW	PRESION AIRE AIR PRESSURE							
bar	3	4	4,5	5	5,5	6	7	8
p.s.i	43,5	58	65,3	72,5	79,8	87	101,5	116
Nm	7,9	11,3	12,7	14,1	15,5	17	19,8	22,9
Lb.in	69,9	100	112,4	124,8	137,2	150,5	175,2	202,7

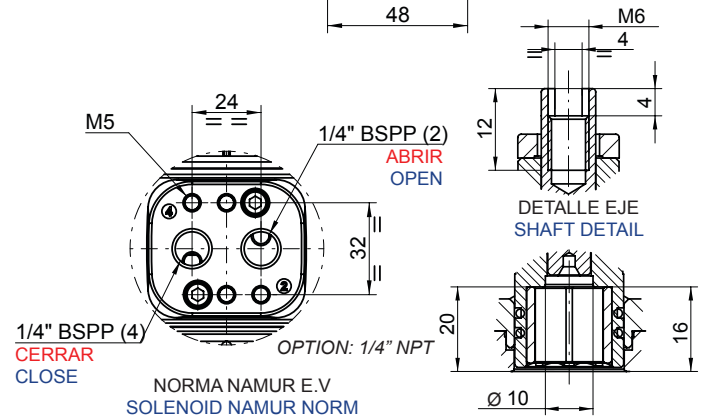

PARES SIMPLE EFECTO SPRING RETURN TORQUES

PAGWS	PAR MUELLES SPRING TORQUES		PAR A LA PRESIÓN INDICADA AIR TORQUE AT INDICATED PRESSURE																
			3		4		4,5		5		5,5		6		7		8		bar
N	INICIAL INITIAL	FINAL END	INICIAL INITIAL	FINAL END	INICIAL INITIAL	FINAL END	INICIAL INITIAL	FINAL END	INICIAL INITIAL	FINAL END	INICIAL INITIAL	FINAL END	INICIAL INITIAL	FINAL END	INICIAL INITIAL	FINAL END	INICIAL INITIAL	FINAL END	p.s.i
4*	9,7	6,1					6,6	3	8	4,4	9,4	5,8	10,9	7,3	13,7	10,1	16,8	13,2	Nm
	86,1	53,8					58,6	26,3	71	38,7	83,4	51,1	96,6	64,3	121,4	89,1	148,9	116,6	Lb.in
3	8,8	5,5			5,8	2,5	7,2	3,9	8,6	5,3	10	6,7	11,5	8,2	14,3	11	17,4	14,1	Nm
	78,1	48,4			51,6	21,9	64	34,3	76,4	46,7	88,8	59,1	102	72,4	126,8	97,2	154,3	124,6	Lb.in
2	6,7	4,3	3,6	1,2	7	4,6	8,4	6	9,8	7,4	11,2	8,8	12,7	10,3	15,5	13,1			Nm
	59	37,7	32,2	10,7	62,3	40,8	74,7	53,4	87,1	65,6	99,5	78	112,8	91,3	137,5	116			Lb.in
1	4,3	2,4	5,5	3,6	8,9	7	10,3	8,4	11,7	9,8	13,1	11,2	14,6	12,7					Nm
	37,7	21,5	48,4	32,2	78,5	62,3	90,9	74,7	103,3	87,1	115,7	99,5	129	112,8					Lb.in

N: Número de muelles por banda
Number of springs per side

* Número de muelles estándar
* Standard number of springs

DESPIECE

DISASSEMBLY



Nº	Descripción Description	Cant. Quant.	Material Material
1	TORNILLO AVELLANADO TAPA CAP COUNTERSUNK SCREW	8	ACERO INOXIDABLE AISI-304 AISI-304 STAINLESS STEEL
2	TAPA CAP	2	ALEACIÓN ALUMINIO (2) + (7) ALUMINIUM ALLOY (2) + (7)
3	JUNTA TÓRICA TAPA CAP-O-RING	2	N.B.R. N.B.R.
4	EMBOLO PISTON	2	ALEACIÓN ALUMINIO (2) ALUMINIUM ALLOY (2)
5	CILINDRO CYLINDER	1	ALEACIÓN DE ALUMINIO (2) + (1) ALUMINIUM ALLOY (2) + (1)
6	ARANDELA WASHER	1	POLIACETAL POLYACETAL
7	ANILLO DE SEGURIDAD SPRING CLIP	1	ACERO INOXIDABLE STAINLESS STEEL
8	INDICADOR VISUAL POSITION INDICATOR	1	POLIAMIDA POLYAMIDE
9	GUIA EMBOLO PISTON GUIDE	2	NYLON NYLON
10	ANILLO GUIA GUIDE RING	2	POLIACETAL + Mb POLYACETAL + Mb
11	JUNTA TÓRICA EMBOLO PISTON O-RING	2	N.B.R. N.B.R.
12	JUNTA TÓRICA EJE SHAFT O-RING	2	N.B.R. N.B.R.
13	JUNTA TÓRICA EJE SHAFT O-RING	2	N.B.R. N.B.R.
14	JUEGO DE MUELLES SPRINGS SET	2	DIN-17223-C (2) (4) DIN-17223-C (2) (4)
15	PLACA BASE (ISO-5211) BASE PLATE (ISO-5211)	1	POLIAMIDA + FV POLYAMIDE + FG
16	EJE SHAFT	1	ACERO (2) STEEL (2)
17	LEVA CAM	1	ACERO (2) STEEL (2)
18	TORNILLO ALLEN ALLEN SCREW	2	ACERO INOXIDABLE AISI-304 AISI-304 STAINLESS STEEL
19	TUERCA NUT	4	ACERO INOXIDABLE AISI-304 AISI-304 STAINLESS STEEL
20	JUNTA TÓRICA PLACA PLATE O-RING	2	N.B.R. N.B.R.
21	TUERCA NUT	4	ACERO INOXIDABLE AISI-304 AISI-304 STAINLESS STEEL
22	PLACA CONEXIÓN NEUMÁTICA PNEUMATIC CONNECTION PLATE	1	POLIAMIDA + FV POLYAMIDE + FG
23	TORNILLO ALLEN PLACA PLATE ALLEN SCREW	2	ACERO INOXIDABLE AISI-304 AISI-304 STAINLESS STEEL
24	TORNILLO HEXAGONAL HEXAGONAL SCREW	2	ACERO INOXIDABLE AISI-304 AISI-304 STAINLESS STEEL
25	TUERCA NUT	2	ACERO INOXIDABLE AISI-304 AISI-304 STAINLESS STEEL
26	ARANDELA BUSHING	2	ACERO INOXIDABLE AISI-304 AISI-304 STAINLESS STEEL
27	JUNTA TÓRICA O-RING	2	N.B.R. N.B.R.

ACTUADOR NEUMÁTICO DE ALUMINIO
(GIRO: 180°)
ALUMINIUM PNEUMATIC ACTUATOR
(ROTATION: 180°)



PAG00: Doble Efecto / Double Acting
PAG00S: Simple Efecto / Spring Return

- (1) RECUBRIMIENTO CON POLIAMIDA.
COVERED WITH POLYAMIDE.
- (2) RECUBRIMIENTO POR CATAFORESIS.
COVERED BY CATAPHORESIS.
- (4) CANTIDAD VARIABLE, CONSULTAR
TABLAS PARES SIMPLE EFECTO.
VARIABLE QUANTITY, PLEASE SEE THE
SPRING RETURN TORQUE CHART.
- (7) RECUBRIMIENTO CON POLIURETANO.
COVERED WITH POLYURETHANE.

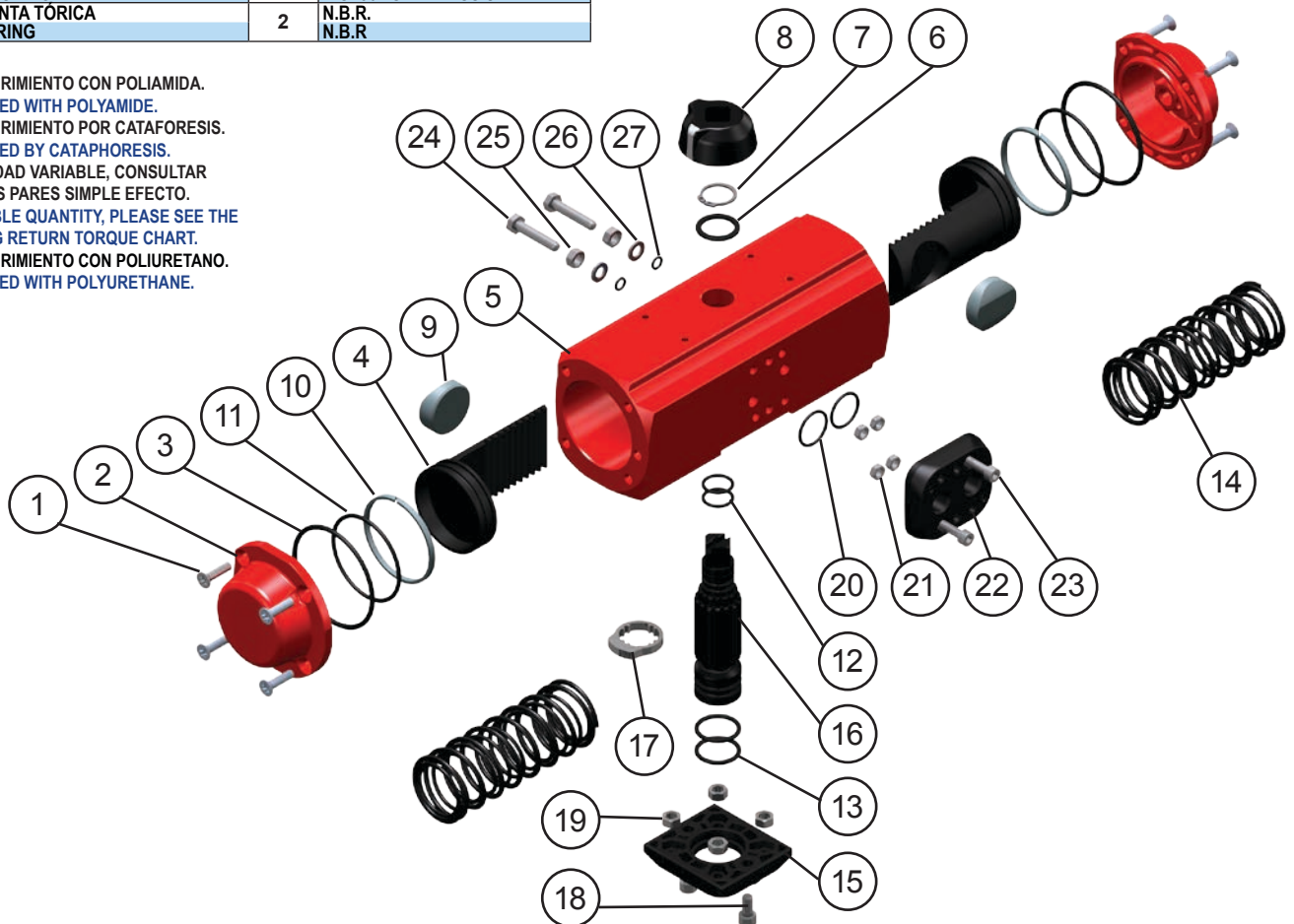

MODELOS MODELS	TIEMPO DE MANIOBRA EN SEG. CYCLE TIME IN SECS.		PESOS WEIGHTS		CAPACIDAD EN LITROS CAPACITY IN LITRES	
	PARA ABRIR TO OPEN	PARA CERRAR TO CLOSE	Kg.	Lb.	PARA ABRIR TO OPEN	PARA CERRAR TO CLOSE
PAG00	0,2	0,2	2,1	18,6	0,21	0,25
PAG00S	0,25	0,25	2,5	22,1	0,21	-

Tiempo de maniobra sin par resistente a 6 bar.
Cycle time w/o resistant torque at 6 bar.

Dimensiones en mm.
Dimensions in mm.

Para calcular el consumo, multiplicar las cifras del cuadro por la presión real de trabajo.

To calculate the consumption, multiply the above figures by the real working pressure.

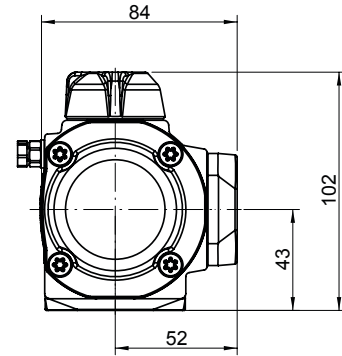
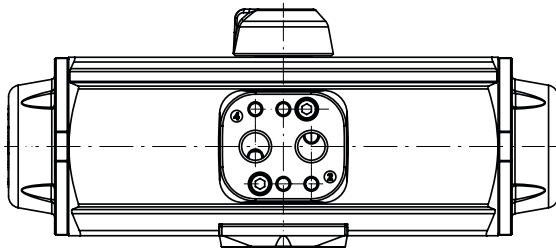
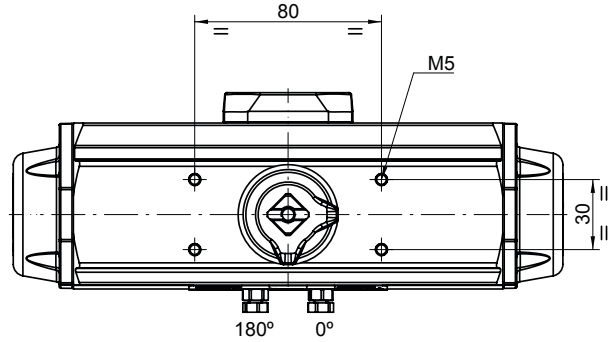
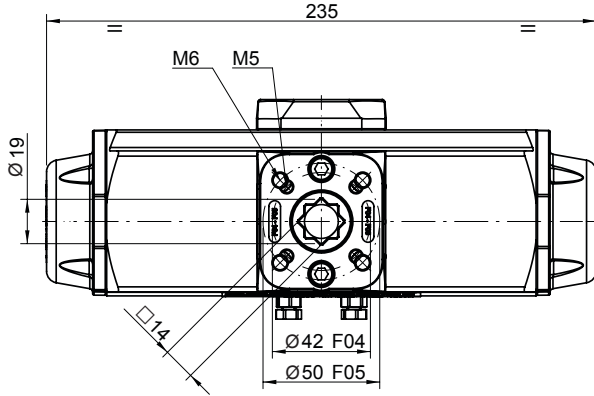

PARES DOBLE EFECTO DOUBLE ACTING TORQUES

PAG00	PRESION AIRE AIR PRESSURE							
bar	3	4	4,5	5	5,5	6	7	8
p.s.i	43,5	58	65,3	72,5	79,8	87	101,5	116
Nm	13,3	18,3	20,9	23,4	26	28,5	33,6	38,7
Lb.in	117,7	162	184,6	207,1	230,1	252,2	297,4	342,5

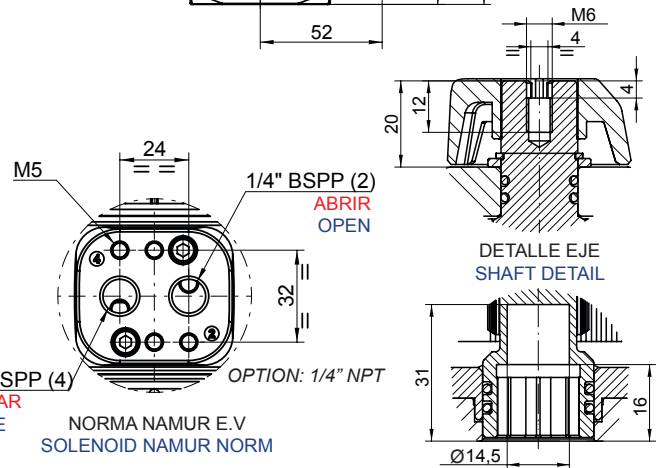

PARES SIMPLE EFECTO SPRING RETURN TORQUES

PAG00S	PAR MUELLES SPRING TORQUES		PAR A LA PRESIÓN INDICADA AIR TORQUE AT INDICATED PRESSURE																
			3		4		4,5		5		5,5		6		7		8		bar
N	INICIAL INITIAL	FINAL END	43,5	58	65,3	72,5	79,8	87	101,5	116									p.s.i
4*	17,8	13,8					7,1	3,1	9,6	5,6	12,2	8,2	14,7	10,7	19,8	15,8	24,9	20,9	Nm
	157,5	122,1					62,8	27,4	85,0	49,6	108,0	72,6	130,1	94,7	175,2	139,8	220,4	185,0	Lb.in
3	15,3	11,2			7,1	3,0	9,7	5,6	12,2	8,1	14,8	10,7	17,3	13,2	22,4	18,3	27,5	23,4	Nm
	135,4	99,1			62,8	26,6	85,8	49,6	108,0	71,7	131,0	94,7	153,1	116,8	198,2	162,0	243,4	207,1	Lb.in
2	11,7	8,7	4,6	1,6	9,6	6,6	12,2	9,2	14,7	11,7	17,3	14,3	19,8	16,8	24,9	21,9	30,0	27,0	Nm
	103,5	77,0	40,7	14,2	85,0	58,4	108,0	81,4	130,1	103,5	153,1	126,6	175,2	148,7	220,4	193,8	265,5	239,0	Lb.in
1	6,6	5,1	8,2	6,7	13,2	11,7	15,8	14,3	18,3	16,8	20,9	19,4	23,4	21,9	28,5	27,0	33,6	32,1	Nm
	58,4	45,1	72,6	59,3	116,8	103,5	139,8	126,6	162,0	148,7	185,0	171,7	207,1	193,8	252,2	239,0	297,4	284,1	Lb.in

N: Número de muelles por banda
Number of springs per side

* Número de muelles estándar
* Standard number of springs

DESPIECE

DISASSEMBLY



Nº	Descripción Description	Cant. Quant.	Material Material
1	TORNILLO AVELLANADO TAPA CAP COUNTERSUNK SCREW	8	ACERO INOXIDABLE AISI-304 AISI-304 STAINLESS STEEL
2	TAPA CAP	2	ALEACIÓN ALUMINIO (2) + (7) ALUMINIUM ALLOY (2) + (7)
3	JUNTA TÓRICA TAPA CAP-O-RING	2	N.B.R. N.B.R.
4	ÉMBOLO PISTON	2	ALEACIÓN ALUMINIO (2) ALUMINIUM ALLOY (2)
5	CILINDRO CYLINDER	1	ALEACIÓN DE ALUMINIO (2) + (1) ALUMINIUM ALLOY (2) + (1)
6	ARANDELA WASHER	1	POLIACETAL POLYACETAL
7	ANILLO DE SEGURIDAD SPRING CLIP	1	ACERO INOXIDABLE STAINLESS STEEL
8	INDICADOR VISUAL POSITION INDICATOR	1	POLIAMIDA POLYAMIDE
9	GUÍA ÉMBOLO PISTON GUIDE	2	POLIACETAL POLYACETAL
10	ANILLO GUÍA GUIDE RING	2	POLIACETAL + Mb POLYACETAL + Mb
11	JUNTA TÓRICA ÉMBOLO PISTON O-RING	2	N.B.R. N.B.R.
12	JUNTA TÓRICA EJE SHAFT O-RING	2	N.B.R. N.B.R.
13	JUNTA TÓRICA EJE SHAFT O-RING	2	N.B.R. N.B.R.
14	MUELLES PRECARGADOS PRELOADED SPRINGS	12	DIN-17223-C (6) (4) DIN-17223-C (4) (4)
15	LEVA CAM	1	ACERO (2) STEEL (2)
16	EJE SHAFT	1	ACERO (2) STEEL (2)
17	JUNTA TÓRICA PLACA PLATE O-RING	2	N.B.R. N.B.R.
18	TUERCA NUT	4	ACERO INOXIDABLE AISI-304 AISI-304 STAINLESS STEEL
19	PLACA CONEXIÓN NEUMÁTICA PNEUMATIC CONNECTION PLATE	1	POLIAMIDA + FV POLYAMIDE + FG
20	TORNILLO ALLEN PLACA PLATE ALLEN SCREW	2	ACERO INOXIDABLE AISI-304 AISI-304 STAINLESS STEEL
21	TORNILLO HEXAGONAL HEXAGONAL SCREW	2	ACERO STEEL
22	TUERCA NUT	2	ACERO INOXIDABLE AISI-304 AISI-304 STAINLESS STEEL
23	ARANDELA BUSHING	2	ACERO INOXIDABLE AISI-316 AISI-316 STAINLESS STEEL
24	JUNTA TÓRICA O-RING	2	N.B.R. N.B.R.
25	CREMALLERA SPUR RACK	1	ACERO (8) STEEL (8)

ACTUADOR NEUMÁTICO DE ALUMINIO
(GIRO: 180°)
ALUMINIUM PNEUMATIC ACTUATOR
(ROTATION: 180°)

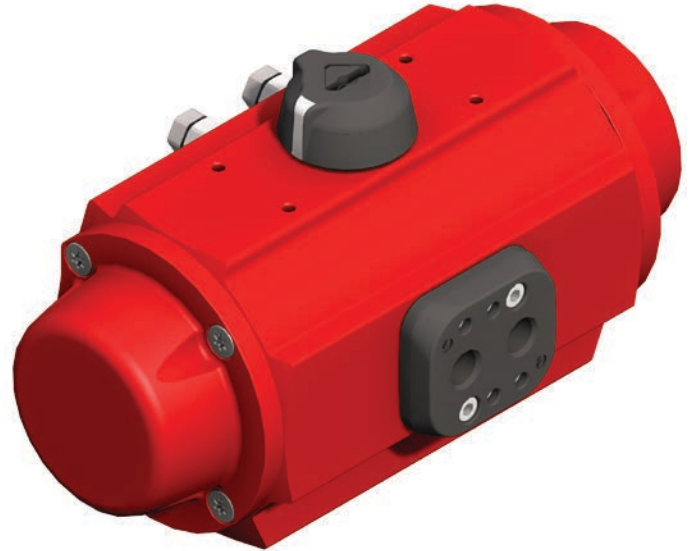

PAG10: Doble Efecto / Double Acting
PAG10S: Simple Efecto / Spring Return

- (1) RECUBRIMIENTO CON POLIAMIDA.
COVERED WITH POLYAMIDE.
- (2) RECUBRIMIENTO POR CATAFORESIS.
COVERED BY CATHAPHORESIS.
- (3) RECUBIERTO CON NÍQUEL-TEFLON.
COVERED BY NIKEL-P.T.F.E.
- (4) CANTIDAD VARIABLE, CONSULTAR
TABLAS PARES SIMPLE EFECTO.
VARIABLE QUANTITY, PLEASE SEE THE
SPRING RETURN TORQUE CHART.
- (5) BRUÑIDO CON BOLAS.
BALL BURNISHING.
- (6) PASIVADO DE CROMO TRIVALENTE.
TRIVALENT CHROMINIUM PASSIVATION.
- (7) RECUBRIMIENTO CON POLIURETANO.
COVERED WITH POLYURETHANE.
- (8) ZINCADO.
ZINC COATED.

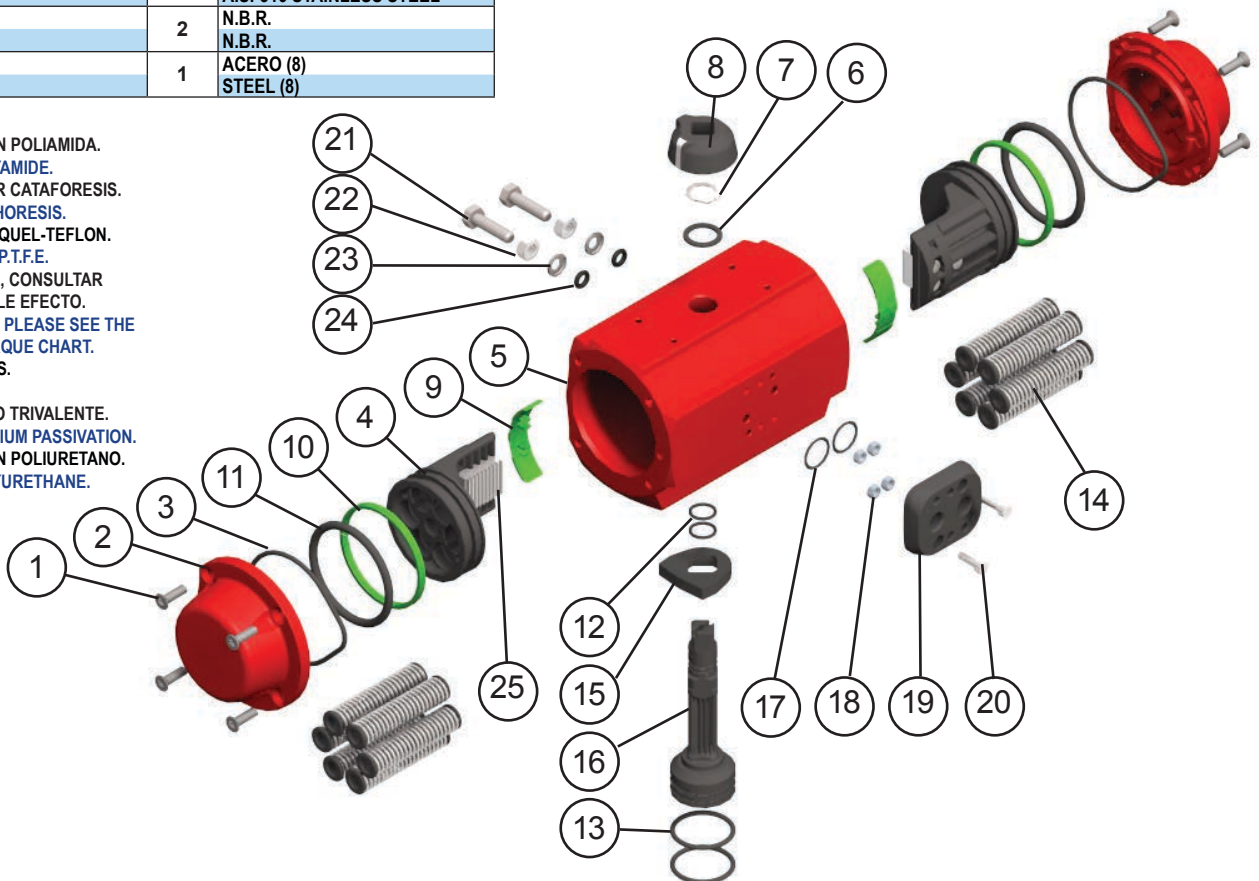

MODELOS MODELS	TIEMPO DE MANIOBRA EN SEG. CYCLE TIME IN SECS.		PESOS WEIGHTS		CAPACIDAD EN LITROS CAPACITY IN LITRES	
	PARA ABRIR TO OPEN	PARA CERRAR TO CLOSE	Kg.	Lb.	PARA ABRIR TO OPEN	PARA CERRAR TO CLOSE
PAG10	0,25	0,25	3,1	6,82	0,35	0,45
PAG10S	0,3	0,3	3,5	7,7	0,35	

Tiempo de maniobra sin par resistente a 6 bar.
Cycle time w/o resistant torque at 6 bar.

Dimensiones en mm.
Dimensions in mm.

Para calcular el consumo, multiplicar las cifras del cuadro por la presión real de trabajo.

To calculate the consumption, multiply the above figures by the real working pressure.

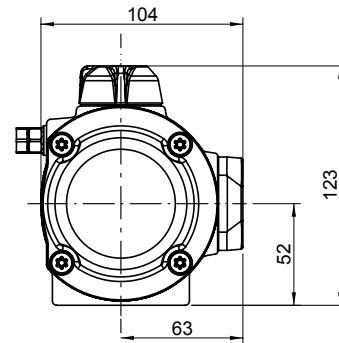
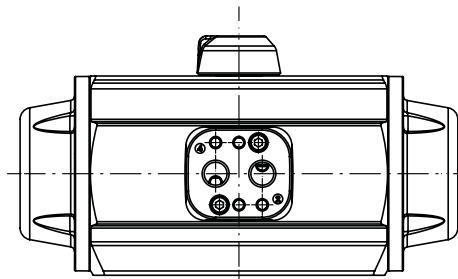
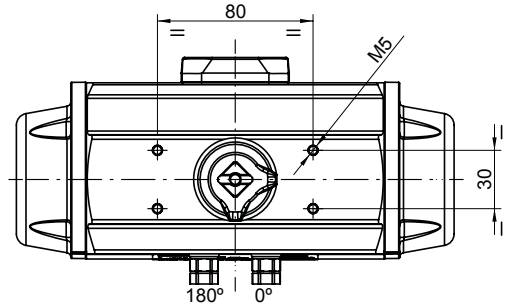
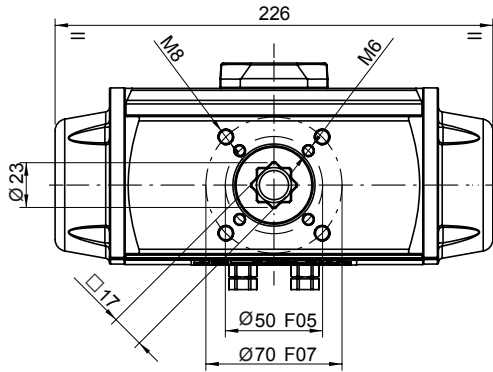

PARES DOBLE EFECTO DOUBLE ACTING TORQUES

PAG10	PRESION AIRE AIR PRESSURE							
bar	3	4	4,5	5	5,5	6	7	8
p.s.i	43,5	58	65,3	72,5	79,8	87	101,5	116
Nm	16,5	22,8	26	29,2	33	36	41,9	48,2
Lb.in	146	202	230	258	288	314	370	427

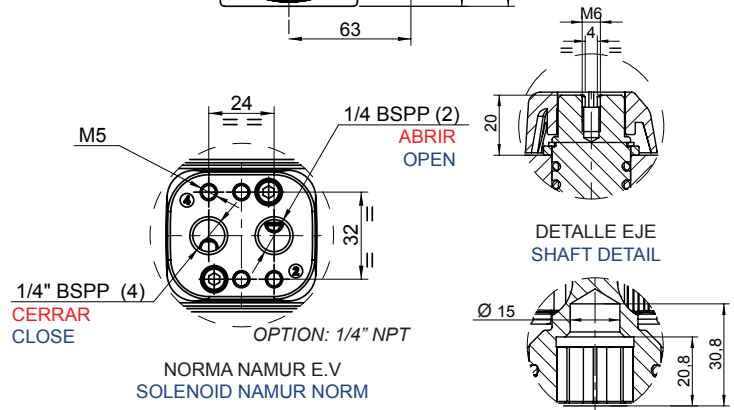

PARES SIMPLE EFECTO SPRING RETURN TORQUES

PAG10S	PAR MUELLES SPRING TORQUES		PAR A LA PRESIÓN INDICADA AIR TORQUE AT INDICATED PRESSURE																	
	INICIAL INITIAL	FINAL END	3		4		4,5		5		5,5		6		7		8		bar	
N			43,5		58		65,3		72,5		79,8		87		101,5		116		p.s.i	
6*	22,8	15,4							13,8	6,4	17,1	9,7	20,1	12,7	26,5	19,1	32,8	25,4	Nm	
	201,8	136,3							121,7	56,2	151,3	85,9	177,9	112,4	234,1	168,6	290,3	224,8	Lb.in	
5	19	12,9						13,1	7	16,3	10,2	19,7	13,5	22,7	16,5	29	22,9	35,4	29,2	Nm
	168,2	113,7						116,3	61,8	144,3	89,8	173,9	119	200,5	146	256,7	202,2	312,9	258,4	Lb.in
4	15,2	10,3			12,6	7,6	15,7	10,8	18,9	14	22,3	17,3	25,3	20,3	31,6	26,7	38	33	Nm	
	134,5	90,7			111,1	67,3	139,3	95,5	167,3	123,5	196,9	153,1	223	179,7	279,7	235,9	335,9	292,1	Lb.in	
3	11,4	7,7	8,8	5,1	15,1	11,4	18,3	14,6	21,5	17,8	24,8	21,1	27,8	24,1	34,2	30,5			Nm	
	100,9	68,2	77,4	44,7	133,6	100,9	161,8	129,1	189,8	157,1	219	186,8	246,1	213,3	302,3	269,5			Lb.in	
2	7,6	5,2	11,3	8,9	17,7	15,2	20,8	18,4	24	21,6	27,4	24,9	30,4	27,9					Nm	
	67,3	45,6	100	78,3	156,2	134,5	184,4	162,7	212,4	190,7	242,1	220,4	268,6	246,9					Lb.in	

N: Número de muelles por banda
Number of springs per side

* Número de muelles estándar
* Standard number of springs

DESPIECE

DISASSEMBLY



Nº	Descripción Description	Cant. Quant.	Material Material
1	TORNILLO ALLEN TAPA CAP ALLEN SCREW	8	ACERO INOXIDABLE AISI-304 AISI-304 STAINLESS STEEL
2	TAPA CAP	2	ALEACIÓN ALUMINIO (2) + (7) ALUMINIUM ALLOY (2) + (7)
3	JUNTA TÓRICA TAPA CAP-O-RING	2	N.B.R. N.B.R.
4	ÉMBOLO PISTON	2	ALEACIÓN ALUMINIO (2) ALUMINIUM ALLOY (2)
5	CILINDRO CYLINDER	1	ALEACIÓN DE ALUMINIO (2) + (1) ALUMINIUM ALLOY (2) + (1)
6	ARANDELA WASHER	1	POLIACETAL POLYACETAL
7	ANILLO DE SEGURIDAD SPRING CLIP	1	ACERO INOXIDABLE STAINLESS STEEL
8	INDICADOR VISUAL POSITION INDICATOR	1	POLIAMIDA POLYAMIDE
9	GUÍA ÉMBOLO PISTON GUIDE	2	POLIACETAL POLYACETAL
10	ANILLO GUÍA GUIDE RING	2	POLIACETAL + Mb POLYACETAL + Mb
11	JUNTA TÓRICA ÉMBOLO PISTON O-RING	2	N.B.R. N.B.R.
12	JUNTA TÓRICA EJE SHAFT O-RING	2	N.B.R. N.B.R.
13	JUNTA TÓRICA EJE SHAFT O-RING	2	N.B.R. N.B.R.
14	MUELLES PRECARGADOS PRELOADED SPRINGS	12	DIN-17223-C (6) (4) DIN-17223-C (6) (4)
15	LEVA CAM	1	ACERO (2) STEEL (2)
16	EJE SHAFT	1	ACERO (2) STEEL (2)
17	JUNTA TÓRICA PLACA PLATE O-RING	2	N.B.R. N.B.R.
18	ARANDELA TAPA CAP WASHER	8	ACERO INOXIDABLE AISI-304 AISI-304 STAINLESS STEEL
19	TUERCA ANUT	4	ACERO INOXIDABLE AISI-304 AISI-304 STAINLESS STEEL
20	PLACA CONEXIÓN NEUMÁTICA PNEUMATIC CONNECTION PLATE	1	POLIAMIDA + FV POLYAMIDE + FG
21	TORNILLO ALLEN PLACA PLATE ALLEN SCREW	2	ACERO INOXIDABLE AISI-304 AISI-304 STAINLESS STEEL
22	TORNILLO HEXAGONAL HEXAGONAL SCREW	2	ACERO INOXIDABLE AISI-304 AISI-304 STAINLESS STEEL
23	TUERCA NUT	2	ACERO INOXIDABLE AISI-304 AISI-304 STAINLESS STEEL
24	ARANDELA BUSHING	2	ACERO INOXIDABLE AISI-316 AISI-316 STAINLESS STEEL
25	JUNTA TÓRICA O-RING	2	N.B.R. N.B.R.
26	CREMALLERA SPUR RACK	1	ACERO (8) STEEL (8)

ACTUADOR NEUMÁTICO DE ALUMINIO
(GIRO: 180°)
ALUMINIUM PNEUMATIC ACTUATOR
(ROTATION: 180°)



PAG20: Doble Efecto / Double Acting
PAG20S: Simple Efecto / Spring Return

- (1) RECUBRIMIENTO CON POLIAMIDA.
COVERED WITH POLYAMIDE.
- (2) RECUBRIMIENTO POR CATAFORESIS.
COVERED BY CATHORESIS.
- (3) RECUBIERTO CON NÍQUEL-TEFLON.
COVERED BY NIKEL-P.T.F.E.
- (4) CANTIDAD VARIABLE, CONSULTAR
TABLAS PARES SIMPLE EFECTO.
VARIABLE QUANTITY, PLEASE SEE THE
SPRING RETURN TORQUE CHART.
- (5) BRUÑIDO CON BOLAS.
BALL BURNISHING.
- (6) PASIVADO DE CROMO TRIVALENTE.
TRIVALENT CHROMINIUM PASSIVATION.
- (7) RECUBRIMIENTO CON POLIURETANO.
COVERED WITH POLYURETHANE.
- (8) ZINCADO.
ZINC COATED.

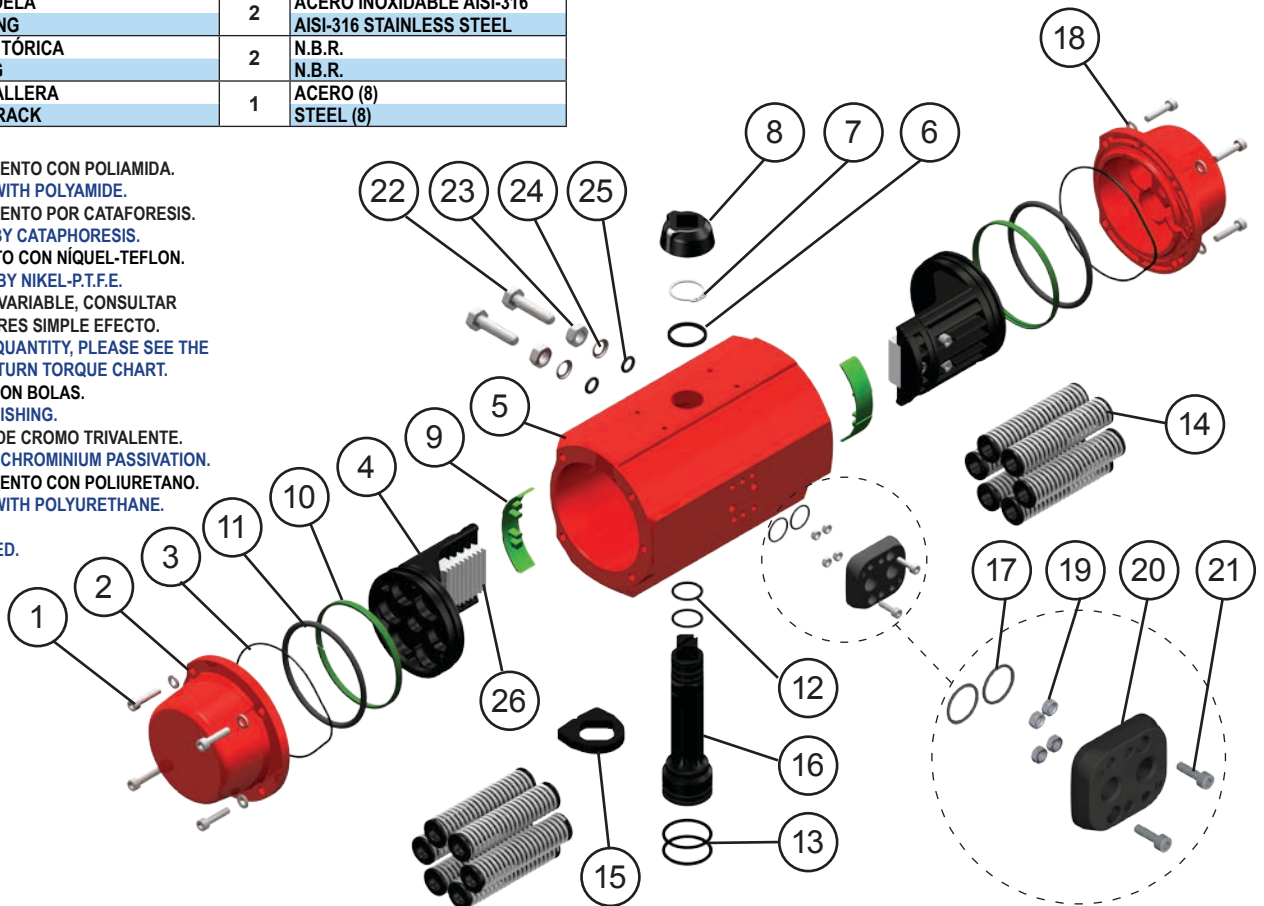

MODELOS MODELS	TIEMPO DE MANIOBRA EN SEG. CYCLE TIME IN SECS.		PESOS WEIGHTS		CAPACIDAD EN LITROS CAPACITY IN LITRES	
	PARA ABRIR TO OPEN	PARA CERRAR TO CLOSE	Kg.	Lb.	PARA ABRIR TO OPEN	PARA CERRAR TO CLOSE
PAG20	0,4	0,4	5,61	12,36	0,8	1,15
PAG20S	0,5	0,5	6,63	14,61	0,8	

Tiempo de maniobra sin par resistente a 6 bar.
Cycle time w/o resistant torque at 6 bar.

Dimensiones en mm.
Dimensions in mm.

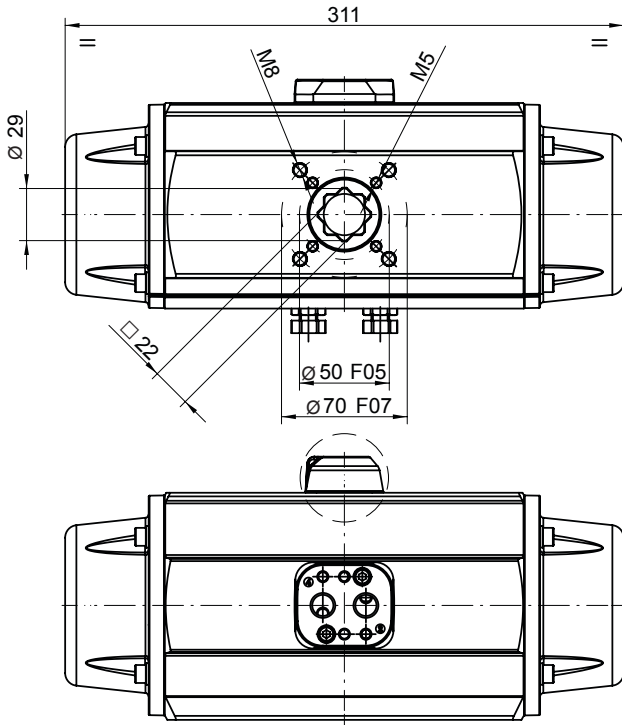

Para calcular el consumo, multiplicar las cifras del cuadro por la presión real de trabajo.

To calculate the consumption, multiply the above figures by the real working pressure.

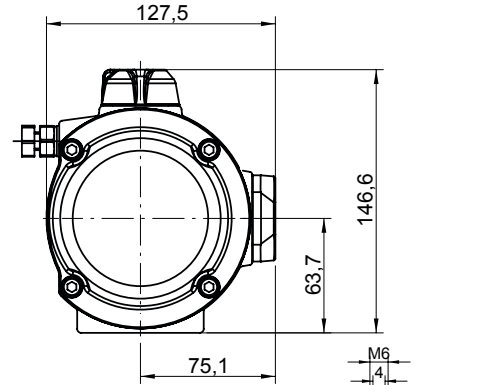
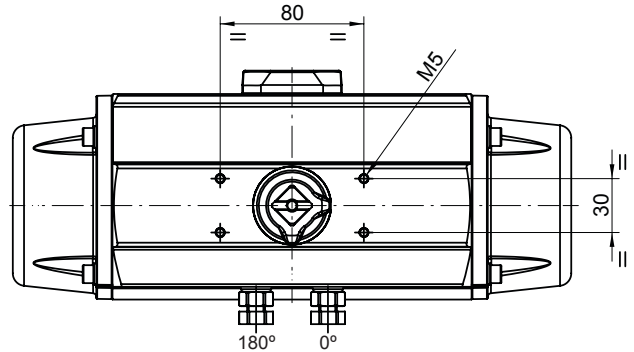

PARES DOBLE EFECTO DOUBLE ACTING TORQUES

PAG20	PRESION AIRE AIR PRESSURE							
bar	3	4	4,5	5	5,5	6	7	8
p.s.i	43,5	58	65,3	72,5	79,8	87	101,5	116
Nm	38,9	53,5	60,9	68,2	75,5	82,8	97,4	112
Lb.in	344	474	539	604	668	733	862	991

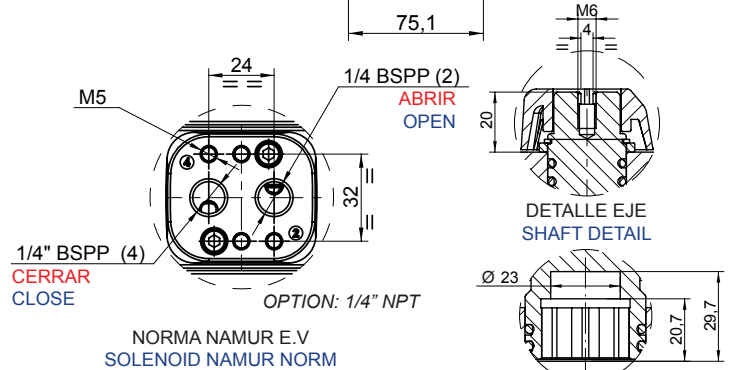

PARES SIMPLE EFECTO SPRING RETURN TORQUES

PAG20S	PAR MUELLES SPRING TORQUES		PAR A LA PRESIÓN INDICADA AIR TORQUE AT INDICATED PRESSURE																
			3		4		4,5		5		5,5		6		7		8		bar
N	INICIAL INITIAL	FINAL END	INICIAL INITIAL	FINAL END	INICIAL INITIAL	FINAL END	INICIAL INITIAL	FINAL END	INICIAL INITIAL	FINAL END	INICIAL INITIAL	FINAL END	INICIAL INITIAL	FINAL END	INICIAL INITIAL	FINAL END	INICIAL INITIAL	FINAL END	p.s.i
6*	52,3	32,9					28	8,6	35,3	15,9	42,6	23,2	49,9	30,5	64,5	45,1	79,1	59,7	Nm
	462,9	291,2					247,8	76,1	312,4	140,7	377	205,3	441,7	269,9	570,9	399,2	700,1	528,4	Lb.in
5	43,6	27,4			26,1	9,9	33,5	17,3	40,8	24,6	48,1	31,9	55,4	39,2	70	53,8	84,6	68,4	Nm
	385,9	243			231	87,6	296	153,1	361,1	217,7	425,7	282,3	490,3	346,9	619,6	476,2	748,8	605,4	Lb.in
4	34,9	21,9	17	4	31,6	18,6	39	26	46,3	33,3	53,6	40,6	60,9	47,9	75,5	62,5	90,1	77,1	Nm
	308,9	193,8	150,5	35,4	279,7	164,6	345,2	230,1	409,8	294,7	474,4	359,3	539	423,9	668,2	553,2	797,5	682,4	Lb.in
3	26,1	16,6	22,3	12,8	36,9	27,4	44,3	34,8	51,6	42,1	58,9	49,4	66,2	56,7	80,8	71,3			Nm
	231	146,9	197,4	113,3	326,6	242,5	392,1	308	456,7	372,6	521,3	437,2	585,9	501,8	715,1	631,1			Lb.in
2	17,4	10,9	28	21,5	42,6	36,1	50	43,5	57,3	50,8	64,6	58,1	71,9	65,4					Nm
	154	96,5	247,8	190,3	377	319,5	442,5	385	507,1	449,6	571,8	514,2	636,4	578,8					Lb.in

N: Número de muelles por banda
Number of springs per side

* Número de muelles estándar
* Standard number of springs

DESPIECE

DISASSEMBLY



Nº	Descripción Description	Cant. Quant.	Material Material
1	TORNILLO ALLEN TAPA CAP ALLEN SCREW	8	ACERO INOXIDABLE AISI-304 AISI-304 STAINLESS STEEL
2	TAPA CAP	2	ALEACIÓN ALUMINIO (2) + (7) ALUMINIUM ALLOY (2) + (7)
3	JUNTA TÓRICA TAPA CAP-O-RING	2	N.B.R. N.B.R.
4	ÉMBOLO PISTON	2	ALEACIÓN ALUMINIO (2) ALUMINIUM ALLOY (2)
5	CILINDRO CYLINDER	1	ALEACIÓN ALUMINIO (2) + (1) ALUMINIUM ALLOY (2) + (1)
6	ARANDELA WASHER	1	POLIACETAL POLYACETAL
7	ANILLO DE SEGURIDAD SPRING CLIP	1	ACERO INOXIDABLE STAINLESS STEEL
8	INDICADOR VISUAL POSITION INDICATOR	1	POLIAMIDA POLYAMIDE
9	GUIA ÉMBOLO PISTON GUIDE	2	POLIACETAL POLYACETAL
10	ANILLO GUIA GUIDE RING	2	POLIACETAL + Mb POLYACETAL + Mb
11	JUNTA TÓRICA ÉMBOLO PISTON O-RING	4	N.B.R. N.B.R.
12	JUNTA TÓRICA EJE SHAFT O-RING	2	N.B.R. N.B.R.
13	JUNTA TÓRICA EJE SHAFT O-RING	2	N.B.R. N.B.R.
14	MUELLES PRECARGADOS PRELOADED SPRINGS	12	DIN-17223-C (6) (4) DIN-17223-C (6) (4)
15	LEVA CAM	1	ACERO (2) STEEL (2)
16	EJE SHAFT	1	ACERO (2) STEEL (2)
17	JUNTA TÓRICA PLACA PLATE O-RING	2	N.B.R. N.B.R.
18	ARANDELA TAPA CAP WASHER	8	ACERO INOXIDABLE AISI-304 AISI-304 STAINLESS STEEL
19	TUERCA ANUT	4	ACERO INOXIDABLE AISI-304 AISI-304 STAINLESS STEEL
20	PLACA CONEXIÓN NEUMÁTICA PNEUMATIC CONNECTION PLATE	1	POLIAMIDA + FV POLYAMIDE + FG
21	TORNILLO ALLEN PLACA PLATE ALLEN SCREW	2	ACERO INOXIDABLE AISI-304 AISI-304 STAINLESS STEEL
22	TORNILLO HEXAGONAL HEXAGONAL SCREW	2	ACERO INOXIDABLE AISI-304 AISI-304 STAINLESS STEEL
23	TUERCA NUT	2	ACERO INOXIDABLE AISI-304 AISI-304 STAINLESS STEEL
24	ARANDELA BUSHING	2	ACERO INOXIDABLE AISI-316 AISI-316 STAINLESS STEEL
25	JUNTA TÓRICA O-RING	2	N.B.R. N.B.R.
26	CREMALLERA SPUR RACK	1	ACERO (8) STEEL (8)
27	JUNTA PLANA WATERTIGHTNESS PLANE GASKET	2	NEOPRENO NEOPRENE

ACTUADOR NEUMÁTICO DE ALUMINIO
(GIRO: 180°)
ALUMINIUM PNEUMATIC ACTUATOR
(ROTATION: 180°)

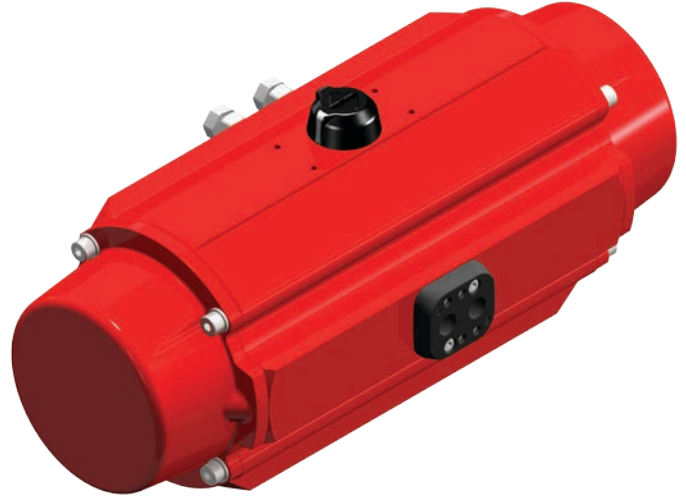

PAG30: Doble Efecto / Double Acting
PAG30S: Simple Efecto / Spring Return

- (1) RECUBRIMIENTO CON POLIAMIDA.
COVERED WITH POLYAMIDE.
- (2) RECUBRIMIENTO POR CATAFORESIS.
COVERED BY CATAPHORESIS.
- (3) RECUBIERTO CON NÍQUEL-TEFLON.
COVERED BY NIKEL-P.T.F.E.
- (4) CANTIDAD VARIABLE, CONSULTAR
TABLAS PARES SIMPLE EFECTO.
VARIABLE QUANTITY, PLEASE SEE THE
SPRING RETURN TORQUE CHART.
- (5) BRUÑIDO CON BOLAS.
BALL BURNISHING.
- (7) RECUBRIMIENTO CON POLIURETANO.
COVERED WITH POLYURETHANE.
- (8) ZINCADO.
ZINC COATED.

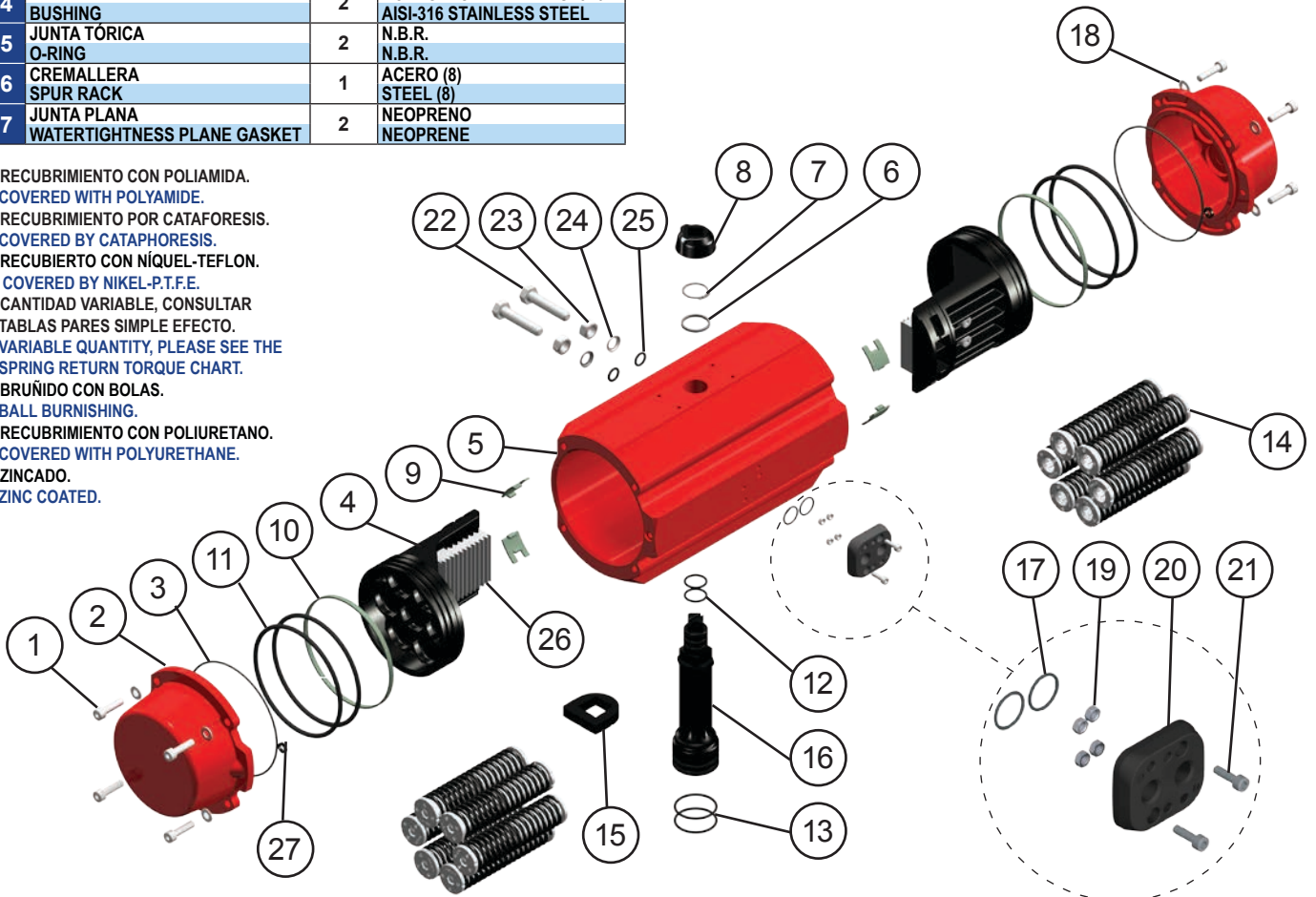

MODELOS MODELS	TIEMPO DE MANIOBRA EN SEG. CYCLE TIME IN SECS.		PESOS WEIGHTS		CAPACIDAD EN LITROS CAPACITY IN LITRES	
	PARA ABRIR TO OPEN	PARA CERRAR TO CLOSE	Kg.	Lb.	PARA ABRIR TO OPEN	PARA CERRAR TO CLOSE
PAG30	1,2	1,2	11,6	25,46	2,05	3
PAG30S	2	2	15,3	33,64	2,05	

Tiempo de maniobra sin par resistente a 6 bar.
Cycle time w/o resistant torque at 6 bar.

Dimensiones en mm.
Dimensions in mm.

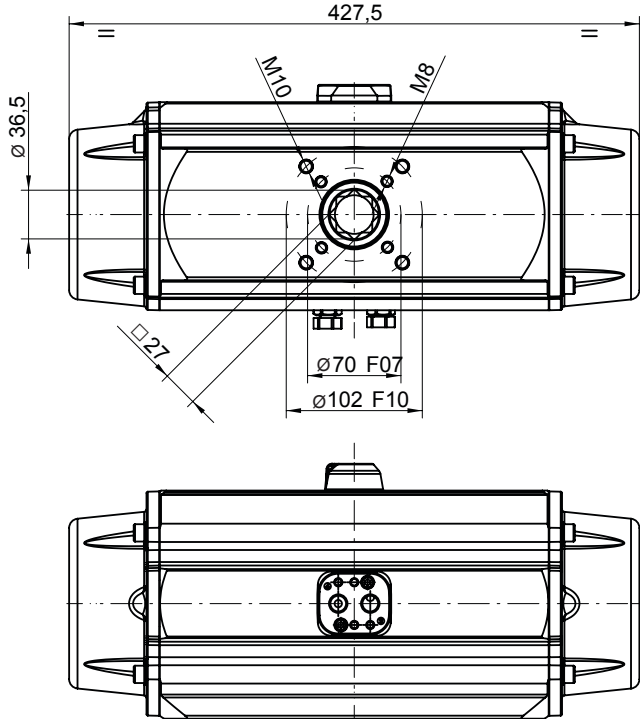

Para calcular el consumo, multiplicar las cifras del cuadro por la presión real de trabajo.

To calculate the consumption, multiply the above figures by the real working pressure.

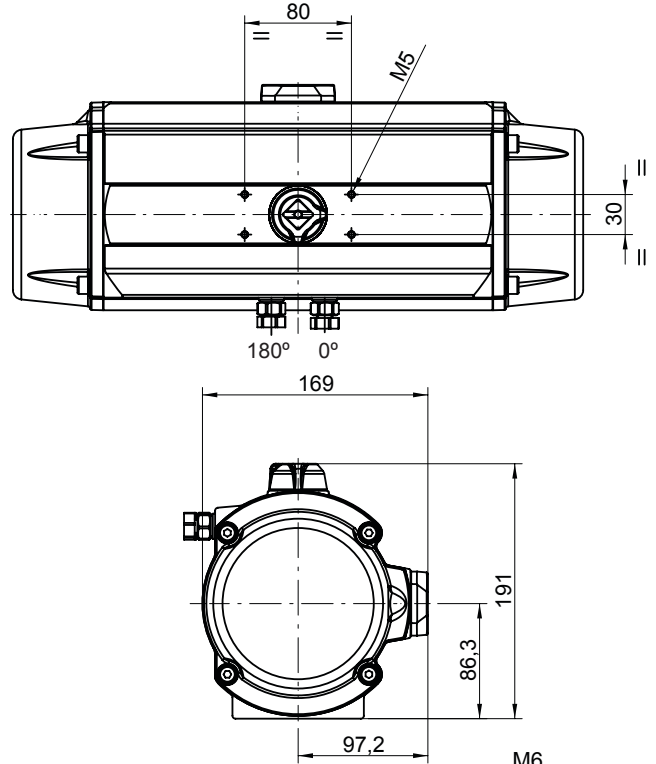

PARES DOBLE EFECTO DOUBLE ACTING TORQUES

PAG30	PRESION AIRE AIR PRESSURE							
bar	3	4	4,5	5	5,5	6	7	8
p.s.i	43,5	58	65,3	72,5	79,8	87	101,5	116
Nm	114,3	157,4	179	200,6	222,1	243,7	286,8	329,9
Lb.in	1.012	1.393	1.584	1.775	1.966	2.157	2.538	2.920

NORMA NAMUR E.V
SOLENOID NAMUR NORM

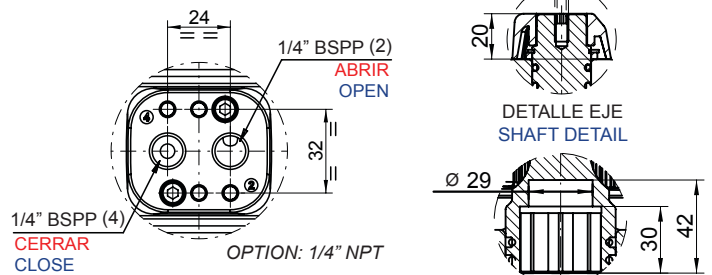

PARES SIMPLE EFECTO SPRING RETURN TORQUES

PAG30S	PAR MUELLES SPRING TORQUES		PAR A LA PRESIÓN INDICADA AIR TORQUE AT INDICATED PRESSURE																
			3		4		4,5		5		5,5		6		7		8		bar
			43,5		58		65,3		72,5		79,8		87		101,5		116		p.s.i
N	INICIAL INITIAL	FINAL END	INICIAL INITIAL	FINAL END	INICIAL INITIAL	FINAL END	INICIAL INITIAL	FINAL END	INICIAL INITIAL	FINAL END	INICIAL INITIAL	FINAL END	INICIAL INITIAL	FINAL END	INICIAL INITIAL	FINAL END	INICIAL INITIAL	FINAL END	
6*	154,8	104,4					74,6	24,2	96,2	45,8	117,7	67,3	139,3	88,9	182,4	132	225,5	175,1	Nm
	1.370	924					660	214	851,4	405,4	1.042	595,7	1.233	786,8	1.614	1.168	1.996	1.550	Lb.in
5	126,8	88,6			68,8	30,6	90,4	52,2	112	73,8	133,5	95,3	155,1	116,9	198,2	160	241,3	203,1	Nm
	1.122	754,2			608,9	270,8	829,8	462	991,3	653,2	1.181	843,5	1.373	1.035	1.754	1.416	2.136	1.798	Lb.in
4	98,8	72,7	41,6	15,5	84,7	58,6	106,3	80,2	127,9	101,8	149,4	123,3	171	144,9	214,1	188	257,2	231,1	Nm
	874,4	643,4	368,2	137,2	749,7	518,7	940,6	709,6	1.132	901	1.322	1.091	1.513	1.282	1.895	1.664	2.276	2.045	Lb.in
3	70,7	56,9	57,4	43,6	100,5	86,7	122,1	108,3	143,7	129,9	165,2	151,4	186,8	173	229,9	216,1			Nm
	625,7	503,6	508	385,9	889,5	767,4	1.080	958,3	1.272	1.150	1.462	1.340	1.653	1.531	2.035	1.913			Lb.in
2	42,7	41,1	73,2	71,6	116,3	114,7	137,9	136,3	159,5	157,9	181	179,4	202,6	201					Nm
	377,9	363,8	647,9	633,7	1.029	1.015	1.220	1.206	1.412	1.397	1602	1.588	1.793	1.779					Lb.in

N: Número de muelles por banda
Number of springs per side

* Número de muelles estándar
* Standard number of springs

Datos sujetos a modificación
Values could change