



FEATURES

- ▶ Angle seat for high flow rate configuration
- ▶ Long life cycles
- ▶ N.C. and N.O. convertible after the delivery
- ▶ Flow below and above the piston
- ▶ Service free solution
- ▶ Ari water hammer

TECHNICAL SPECIFICATION

- ▶ **VALVE FEATURES**
Fluid Temperature: -10°C +180°C
Environment temperature: -10°C +60°C
Material: Stainless Steel AISI 316 series
Seal: PTFE
Packing gland: PTFE, FKM
- ▶ **PILOT ACTUATOR FEATURES**
Media: Dry Air or lubricated, gas and neutral fluids
Fluid Temperature: max +60°C
Body: Polyamide 66 with 30% glass fibre
NBR Gaskets
Actuator Ø 70
Self adjusting Teflon seat

AVAILABLE ON REQUEST

- ▶ Pilot Valve 31A2AV20+BDA (see 31A catalogue page)
- ▶ Together with male thread nipple male 1/4"-1/4"
- ▶ Position indicator
- ▶ Water piloting system



(Pressure Equipment Directive 97/23/CE) for valve 21A7 + 21A9

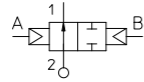

21A	4	T	15	G	A	2	
Model valve	5= G 3/4 - NPT 3/4	T= PTFE	15 20 25 32 40 50	Orefice 10 ⁻³ mm	G= GAS N= NPT	A= N.O.	Actuator connection
	6= G 1 - NPT 1						
	5= G 1 1/4 - NPT 1 1/4						
	6= G 1 1/2 - NPT 1 1/2						
	9= G 2 - NPT 2						

PIPE	Ø (mm)	Kv (l/min)	ACTUATOR PILOT PRESSURE (bar)		DIFFERENTIAL PRESSURE (bar)		MAX ALLOWABLE PRESSURE PS (bar)	GAS CODE	NPT CODE	WEIGHT kg	DRAWING REFERENCE
			min	max	min	max					

Normally Open Ex m

1/2"	15	80	1,5	10	0	(See graphic n. 1)	40	21A4T15GA2	21A4T15NA2	1,2	1
3/4"	20	150	1,5	10	0		40	21A5T20GA2	21A5T20NA2	1,3	1
1"	25	190	1,5	10	0		40	21A6T25GA2	21A6T25NA2	1,6	1
1/4"	32	340	1,5	10	0		25	21A7T32GA2	21A7T32NA2	2,2	1
1/2"	40	430	1,5	10	0		25	21A8T40GA2	21A8T40NA2	2,5	1
2"	50	620	1,5	10	0		16	21A9T50GA2	21A9T50NA2	3,7	1

Normally Open with electrical position indicators

1/2"	15	80	1,5	10	0	(See graphic n. 1)	40	21A4T15GA2-IP1	21A4T15NA2-IP1	1,2	2
3/4"	20	150	1,5	10	0		40	21A5T20GA2-IP1	21A5T20NA2-IP1	1,3	2
1"	25	190	1,5	10	0		40	21A6T25GA2-IP1	21A6T25NA2-IP1	1,6	2
1/4"	32	340	1,5	10	0		25	21A7T32GA2-IP1	21A7T32NA2-IP1	2,2	2
1/2"	40	430	1,5	10	0		25	21A8T40GA2-IP1	21A8T40NA2-IP1	2,5	2
2"	50	620	1,5	10	0		16	21A9T50GA2-IP1	21A9T50NA2-IP1	3,7	2

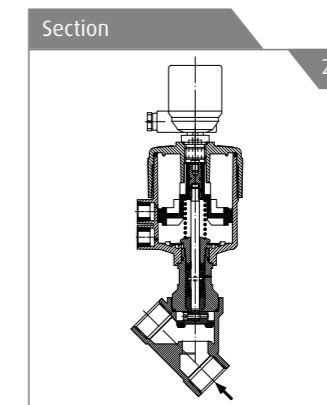
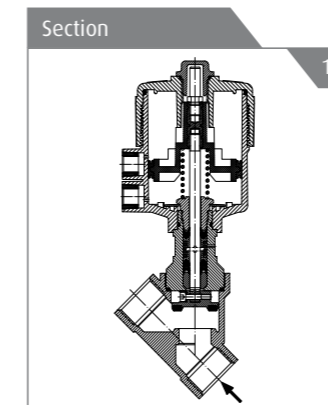

INSTALLATION

- ▶ The solenoid valves can be mounted in any position
- ▶ Maintenance and instruction sheet available in each solenoid valve box

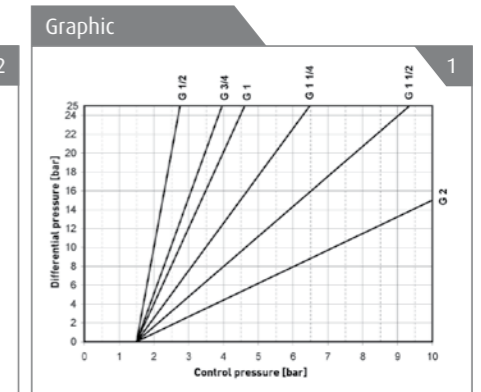
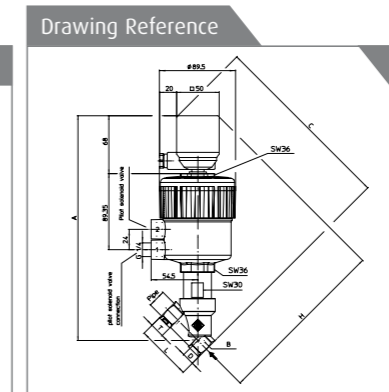
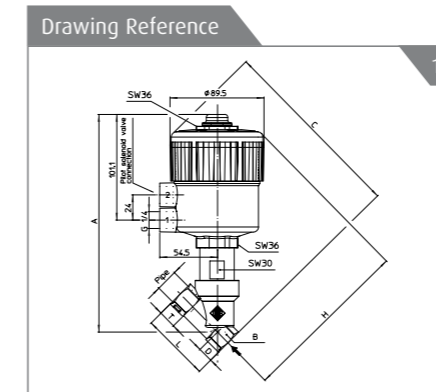

Dimensionale Table

Figure	Pipe	A mm	B mm	C mm	D mm	H mm	L mm	T mm
1-2	1/2"	206,8	SW 27	178,7	15,4	163,3	65	17
	3/4"	211,7	SW 32	188,6	21,9	166,7	75,5	19
	1"	220,1	SW 41	197,8	25,1	172,7	90	21
	1 1/4"	235,9	SW 50	212,3	28,5	183,8	110	24
	1 1/2"	238,9	SW 55	217,0	31,0	186	122	25,2
	2"	247,8	SW 70	229,7	37,5	192,2	151	28,5

Position indicators

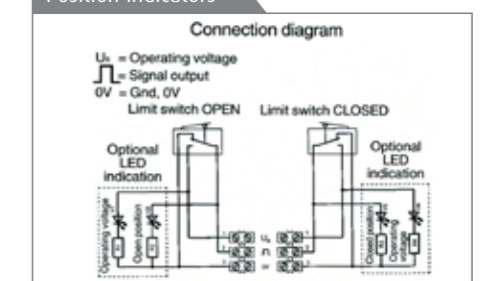



FEATURES

- ▶ Angle seat for high flow rate configuration
- ▶ Long life cycles
- ▶ N.C. and N.O. convertible after the delivery
- ▶ Flow below and above the piston
- ▶ Service free solution
- ▶ Water hammer

TECHNICAL SPECIFICATION

- ▶ **VALVE FEATURES**
Fluid Temperature: -10°C +180°C
Environment temperature: -10°C +60°C
Material: Stainless Steel AISI 316 series
Seal: PTFE
Packing gland: PTFE, FKM
- ▶ **PILOT ACTUATOR FEATURES**
Media: Dry Air or lubricated, gas and neutral fluids
Fluid Temperature: max +60°C
Body: Polyamide 66 with 30% glass fibre
NBR Gaskets
Actuator Ø 70
Self adjusting Teflon seat

AVAILABLE ON REQUEST

- ▶ Pilot Valve 31A2AV20+BDA (see 31A catalogue page)
- ▶ Together with male thread nipple male 1/4"-1/4"
- ▶ Position indicator
- ▶ Double Effect
- ▶ Water piloting system



(Pressure Equipment Directive 97/23/CE) for valve 21A7 + 21A9

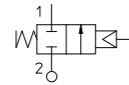

21A	4	T	15	G	C	2	
Model valve	5= G 3/4 - NPT 3/4	T= PTFE	15 20 25 32 40 50	Orefice 10 ³ mm	G= GAS N= NPT	C= N.C. D= Double Effect	Actuator connection
	6= G 1 - NPT 1						
	5= G 1 1/4 - NPT 1 1/4						
	6= G 1 1/2 - NPT 1 1/2						
	9= G 2 - NPT 2						

PIPE	Ø (mm)	Kv (l/min)	ACTUATOR PILOT PRESSURE (bar)		DIFFERENTIAL PRESSURE (bar)		MAX ALLOWABLE PRESSURE PS (bar)	GAS CODE	NPT CODE	WEIGHT kg	DRAWING REFERENCE
			min	max	min	max					

Normally Closed

1/2"	15	80	4	10	0	16	40	21A4T15GC2	21A4T15NC2	1,4	1
3/4"	20	150	4	10	0	10	40	21A5T20GC2	21A5T20NC2	1,5	1
1"	25	190	4	10	0	10	40	21A6T25GC2	21A6T25NC2	1,8	1
1/4"	32	340	4	10	0	7	25	21A7T32GC2	21A7T32NC2	2,4	1
1/2"	40	430	4	10	0	4,5	25	21A8T40GC2	21A8T40NC2	2,7	1
2"	50	620	4	10	0	3	16	21A9T50GC2	21A9T50NC2	3,9	1

Normally Closed high pressure

1/2"	15	80	5	10	0	35	40	21A4T15GC2-H	21A4T15NC2-H	1,4	1
3/4"	20	150	5	10	0	25	40	21A5T20GC2-H	21A5T20NC2-H	1,5	1
1"	25	190	5	10	0	20	40	21A6T25GC2-H	21A6T25NC2-H	1,8	1
1/4"	32	340	5	10	0	13	25	21A7T32GC2-H	21A7T32NC2-H	2,4	1
1/2"	40	430	5	10	0	8	25	21A8T40GC2-H	21A8T40NC2-H	2,7	1
2"	50	620	5	10	0	5,5	16	21A9T50GC2-H	21A9T50NC2-H	3,9	1

Normally Closed high pressure with electrical position indicators

1/2"	15	80	4	10	0	35	40	21A4T15GC2-HIP1	21A4T15NC2-HIP1	1,4	2
3/4"	20	150	4	10	0	25	40	21A5T20GC2-HIP1	21A5T20NC2-HIP1	1,5	2
1"	25	190	4	10	0	20	40	21A6T25GC2-HIP1	21A6T25NC2-HIP1	1,8	2
1/4"	32	340	4	10	0	13	25	21A7T32GC2-HIP1	21A7T32NC2-HIP1	2,4	2
1/2"	40	430	4	10	0	8	25	21A8T40GC2-HIP1	21A8T40NC2-HIP1	2,7	2
2"	50	620	4	10	0	5,5	16	21A9T50GC2-HIP1	21A9T50NC2-HIP1	3,9	2

Normally Closed with electrical position indicators

1/2"	15	80	4	10	0	16	40	21A4T15GC2-IP1	21A4T15NC2-IP1	1,4	2
3/4"	20	150	4	10	0	10	40	21A5T20GC2-IP1	21A5T20NC2-IP1	1,5	2
1"	25	190	4	10	0	10	40	21A6T25GC2-IP1	21A6T25NC2-IP1	1,8	2
1/4"	32	340	4	10	0	7	25	21A7T32GC2-IP1	21A7T32NC2-IP1	2,4	2
1/2"	40	430	4	10	0	4,5	25	21A8T40GC2-IP1	21A8T40NC2-IP1	2,7	2
2"	50	620	4	10	0	3	16	21A9T50GC2-IP1	21A9T50NC2-IP1	3,9	2

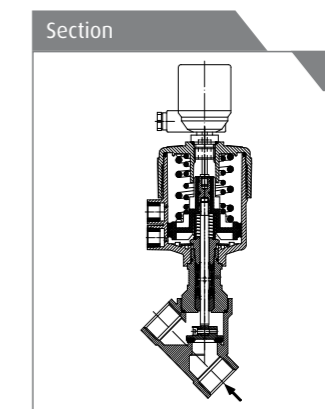
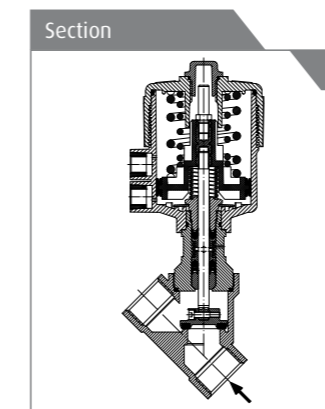

INSTALLATION

- ▶ The solenoid valves can be mounted in any position
- ▶ Maintenance and instruction sheet available in each solenoid valve box

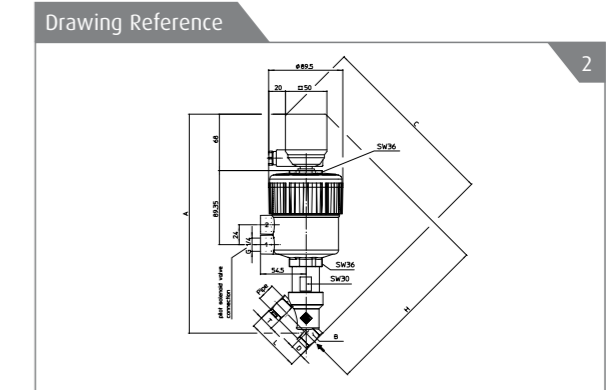
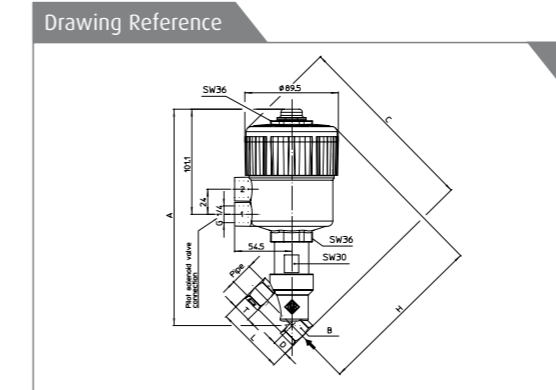

Dimensionale Table

Figure	Pipe	A mm	B mm	C mm	D mm	H mm	L mm	T mm
1-2	1/2"	206,8	SW 27	178,7	15,4	163,3	65	17
	3/4"	211,7	SW 32	188,6	21,9	166,7	75,5	19
	1"	220,1	SW 41	197,8	25,1	172,7	90	21
	1 1/4"	235,9	SW 50	212,3	28,5	183,8	110	24
	1 1/2"	238,9	SW 55	217,0	31,0	186	122	25,2
2"	247,8	SW 70	229,7	37,5	192,2	151	28,5	

Position indicators

