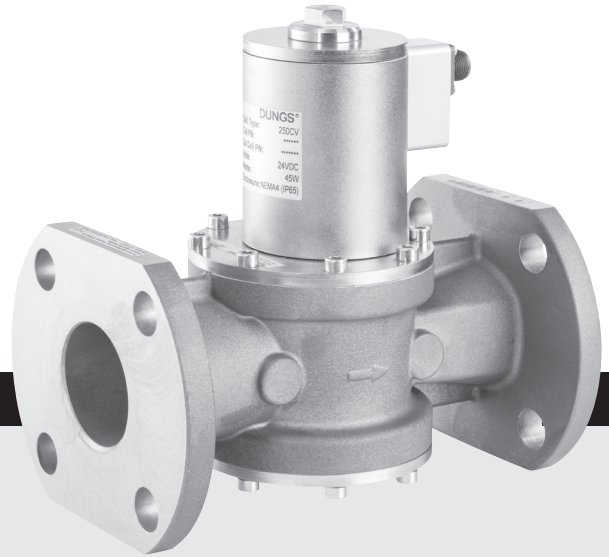

Table of Contents

Table of Contents Page 1
 Approvals Page 1
 Attention Page 1
 Specification Page 2
 Installation Position Page 3
 Mounting Page 3
 Wiring Page 4
 Painting Valve Page 4
 Protection from Radiant Heat Page 4
 Dimensions Page 5
 Valve Leakage Test Page 6
 Flow Curve Page 7
 Accessories & Replacement Page 8



Approvals



CSA Certified: File No. 1010989

ANSI Z21.21 / CSA 6.5
 C/I Marking
 CGA 3.9

Attention



The installation and maintenance of this product must be done under the supervision of an experienced and trained specialist. Never perform work if gas pressure or power is applied, or in the presence of an open flame.

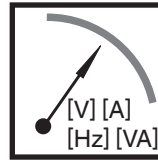

Check the ratings in the specifications verify sure that they are suitable for your application.



Please read the instruction before installing or operating. Keep the instruction in a safe place. You find the instruction also at www.dungs.com If these instructions are not heeded, the result may be personal injury or damage to property.



On completion of work on the safety shutoff valve, perform a leakage and function test.



Any adjustment and application-specific adjustment values must be made in accordance with the equipment manufacturers instructions.



This product is intended for installations covered by, but not limited to, the following fuel gas codes: CSA B149.1 (for Canada), the International Fuel Gas Code, and NFPA 54 or the following equipment codes and standards: CSA B149.3 (for Canada) or NFPA 37.

Explanation of symbols

- 1, 2, 3 ... = Action
- = Instruction



Warning: During normal operation, coil is getting hot. (max. 176 °F / 80 °C)

Specification

HPSV 10020/604

Normally closed automatic shutoff valve. Fast opening, fast closing.

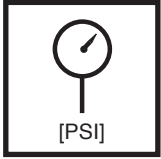

Max. Operating Pressure
 100 PSI (689 kPa) factory rating
 60 PSI (413 kPa) as per ANSI Z21.21/
 CSA 6.5 C/l and 100 PSI as per
 CGA 3.9

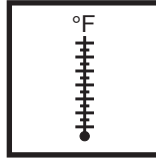

Ambient / Fluid Service Temperature
 CSA -20 °F to +140 °F
 -29 °C to +60 °C
 Factory +5 °F to +140 °F
 -15 °C to +60 °C



Burst Pressure Rating
 500 PSI (3447 kPa)

Electrical Ratings Available
 24 VDC

Power Consumption
 45 W

Storage Temperature
 -40 °F to +185 °F
 -40 °C to +85 °C



Degree of Protection
 NEMA 4/IP65
 Suitable for hazardous locations
 Class I, Division 2, Groups C and D,
 Temperature code T4A.

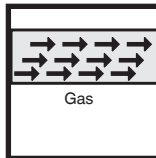

Gases
 Dry, natural gas, propane, butane;
 other noncorrosive gases as well as
 waste-gases and bio-gases contain-
 ing up to a maximum 0.1 % by volume
 (1000 ppm) of H₂S, dry.
 Intended for gaseous fuels only. Can-
 not be used with non-compressible
 fluids (liquids) of any kind.
 (A "dry" gas has a dew point lower
 than + 15 °F and its relative humidity
 is less than 60 %.)

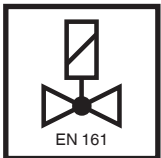

Operating Time
 100 % duty cycle

Closing Time
 < 1 s

Opening Time
 < 1 s

Gas Connection Type
 2" flat face flange per ANSI B16.5
 Class 150

Materials in contact with Gas
 Housing: Anodized Aluminium and
 Steel, free of non-ferrous metals
 Sealings on valve seats: NBR-based
 rubber.



Vibration Resistance
 According to MIL 810 Profile Vibration

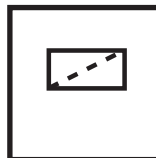

Strainer
 Built-in 1 mm stainless steel mesh
 strainer, installed upstream of the
 valve seat.

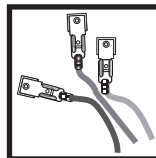

Electrical Connection
 Quick disconnect according to MIL
 ACS02A-10SL-04P-003
 According to CSA C22.1 Part 1

Installation Position

Installation Position

Safety shutoff valve from vertically upright to horizontal.

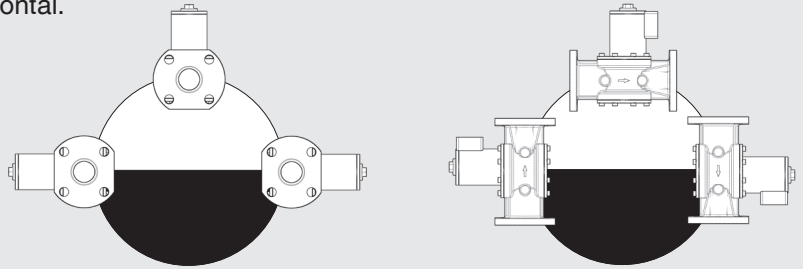

Mounting

HPSV 10020/604 Flanged Mounting Procedure

1. Only install the HPSV 10020/604 safety valve downstream of a 50 micron max. gas filter and with the gas flow matching the direction indicated by the arrows on the casting.
2. Mount the HPSV 10020/604 to a flat face B16.5 flange with the solenoid vertical to horizontal.
3. Insert proper flange seal.
4. Insert studs, tighten in a crisscross pattern to ensure uniform tightness.
5. Do not overtighten studs. Follow the maximum torque values listed.
6. After installation is complete, perform a leak test. (see "Valve Leakage Test")

A manual shutoff valve and a leak test connection shall be installed downstream of the valve in order to provide for proper valve leakage testing.

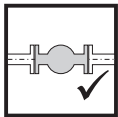
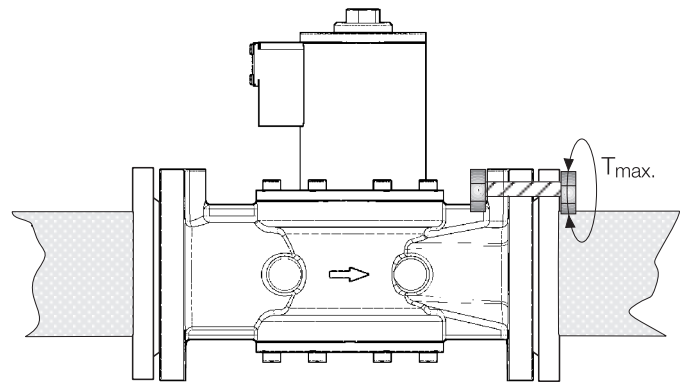

Stress free assembling!

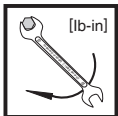

Recommended Torque for Studs

Studs

T_{max}

M16 X 65 mm (DIN 939)

1327 [lb-in] (150 Nm)

Recommended Installation

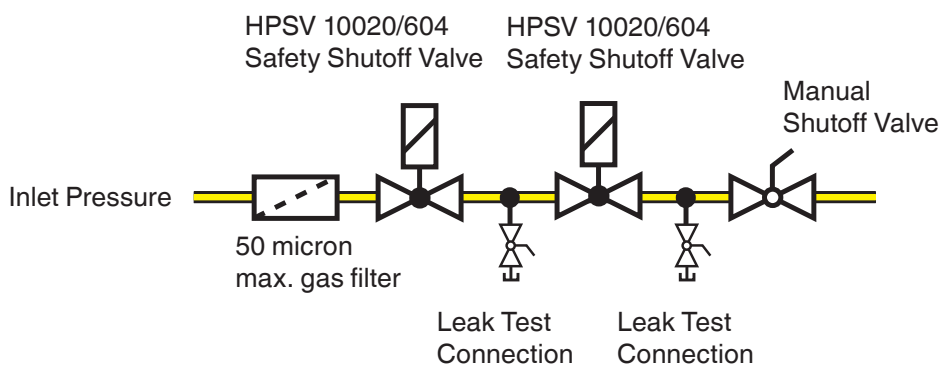

Wiring

Wiring the HPSV 10020/604

1. Disconnect all power to the leads before wiring to prevent electrical shock and equipment damage.
2. Connect the 24 VDC power to the connector 271568 or a similar one. Connector and valve are not polarity sensitive.
3. Install the connector on the valve
4. The connector and the cable shall be suitable for 24 VDC and capable of at least 2 A and rated for at least 75 °



All wiring must comply with local electrical codes and regulations.



Label all wires prior to disconnection when servicing valves. Wiring errors can cause improper and dangerous operation. Verify proper operation after servicing.



No protection elements (diode, fuse, VDR) are implemented in the valve. No rectifier or polarization diodes are applied. There is a direct connection to the solenoid windings. Therefore, the coil is not polarity sensitive.

Electrical Connection

2 Poles connector type Amphenol ASC02A-10SL-04P-003. Connections are not polarity sensitive.

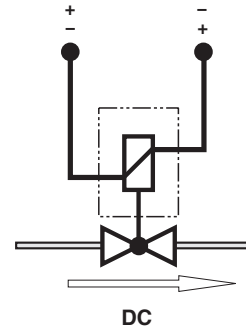

Note: When installed in hazardous locations, the wiring shall be Ex ia, Ex ib, Ex ic, or Nonincendive field wiring, as defined under the Canadian Electrical Code, C22.1 or the National Electrical Code, NFPA 70.

Painting Valve

- It is not recommended that this valve be painted. Painting covers date codes and other labels that identify this valve.
- If the valve needs to be painted, a paint free of volatile organic compounds (VOC's) must be used. VOC's can damage valve o-rings, resulting in external gas leakage over time.
- During the painting process, use measures that will allow the valve's date code and other labeling information to be legible after the paint is dry.

Protection from Radiant Heat

- Radiant heat must be considered as a heat source that could result in an ambient temperature higher than the rating of this valve.
- Provide proper shielding to protect against radiant heat.

Dimensions

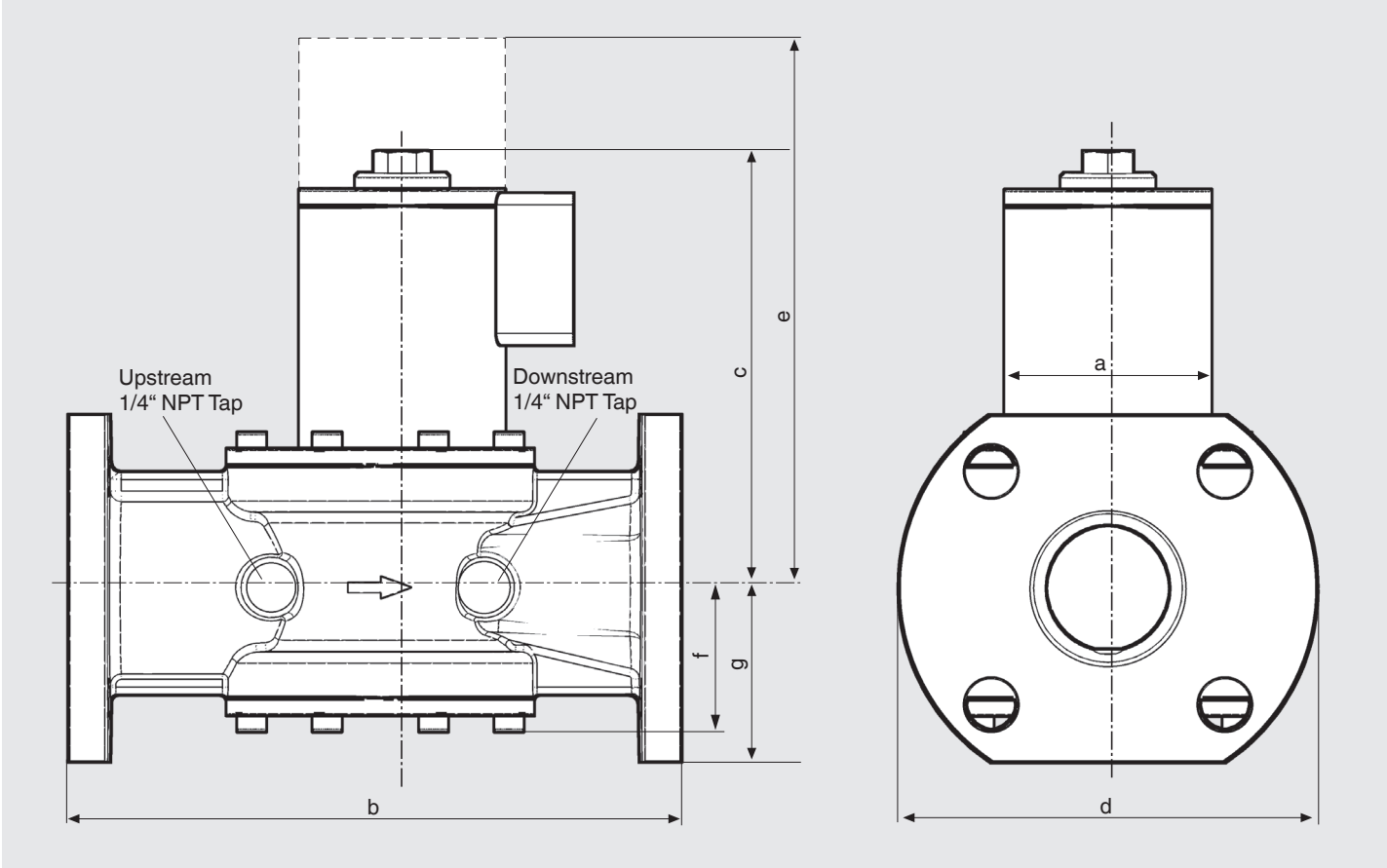

Type	Order No.	Dimensions [inch]							Weight [lbs]
		Dimensions [mm]							
		a	b	c	d	e	f	g	[kg]
HPSV 10020/604 VIP	270890	2.95	8.82	6.30	6.02	9.84	2.09	2.52	13.2
		75	224	160	153	250	53	64	6,0

Valve Leakage Test

This leak test procedure tests the valve seat sealing capabilities of the safety shutoff valve. Only qualified personnel should perform this test.

It is required that this test be done on the initial system startup, and then repeated at least annually. Possibly more often depending on the application, environmental parameters, and the requirements of the authority having jurisdiction.

Setup

This test requires the following:

- A) Test connection installed downstream of the safety shutoff valve to make the required 1/4" hose connection in step 4.
- B) A transparent glass of water filled at least 1 inch from the bottom.
- C) A proper leak test tube. An aluminum or copper 1/4" rigid tube with a 45° cut at the end that is then connected to a 1/4" flexible hose of some convenient length provides for a more accurate leakage measurement. However, a 45° cut at the end of the 1/4" flexible hose will suffice, but it will not likely be as accurate as the rigid tube.

Leak Test Procedure

Use the illustration below as a reference.

1. Close the downstream manual shutoff valve, or safety shutoff valve.
2. Open the downstream test connection and connect the 1/4" flexible hose.
3. Provide for some time to allow potential leakage to charge the test chamber before measuring valve seat leakage.
4. Immerse the 1/4 in. tube vertically 1/2 in. (12.7 mm) below the water surface. If bubbles emerge from the 1/4" tube and after the leakage rate has stabilized, count the number of bubbles.
5. If the number of bubbles exceeds 6 within 10 s, replace the valve.

After completing the above tests proceed as follows:

6. Verify that the downstream manual shutoff valve is closed.
7. Remove the flexible hose, and close the test connection.

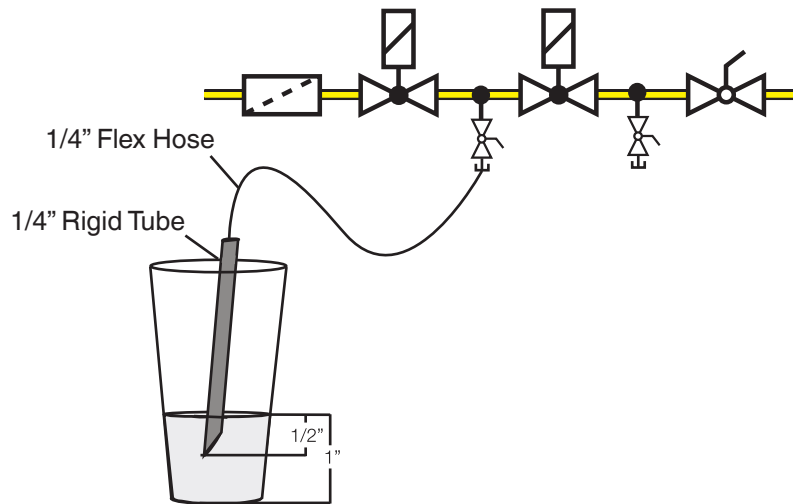

Flow Curve

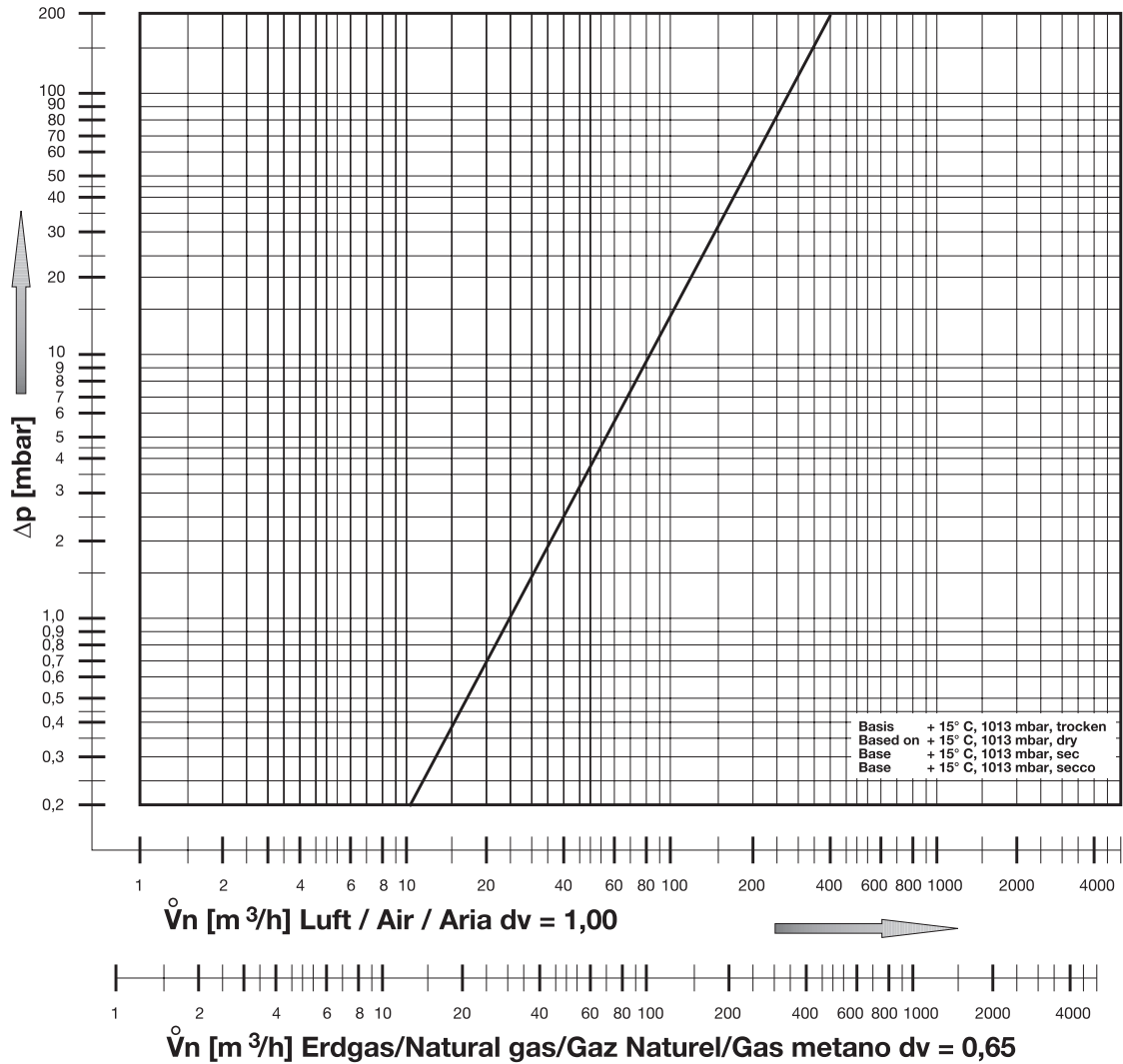

Pressure drop for other gases

To determine the pressure drop when using a gas other than natural gas, use the flow formula below and f value located in the table below to determine

the “corrected” flow rate in CFH through the valve for the other gas used. For example, when using propane, divide the volume (CFH) of propane required for the application by the calculated value

f (f = 0.66 for propane). Use this “corrected” flow rate and the flow curve on the next page to determine pressure drop for propane.

Determining equivalent flow through valves using another gas

$$\dot{V}_{\text{gas used}} = \dot{V}_{\text{Natural gas}} \times f$$

$$f = \frac{\text{Density of Natural gas}}{\text{Density of gas used}}$$

Type of gas	Density [kg/m³]	s.g.	f
Natural gas	0.81	0.65	1.00
Butane	2.39	1.95	0.58
Propane	1.86	1.50	0.66
Air	1.24	1.00	0.80

Accessories & Replacement

Replacement Coil

Valve Type	Voltage	Order No.
HPSV 10020/604 (VIP Coil)	24 VDC	270888
Connector 2 Poles (RoHS)		271568

We reserve the right to make modifications in the course of technical development.

Karl Dungs, Inc.
3890 Pheasant Ridge Drive NE
Suite 150
Blaine, MN 55449, U.S.A.
Phone 763 582-1700
Fax 763 582-1799
e-mail info@karldungsusa.com
Internet <http://www.dungs.com/usa/>

Karl Dungs GmbH & Co. KG
P.O. Box 12 29
D-73602 Schorndorf, Germany
Phone +49 (0)7181-804-0
Fax +49 (0)7181-804-166
e-mail info@dungs.com
Internet <http://www.dungs.com>