

# valvole Namur

Namur valves



La funzione della valvola può essere variata in qualsiasi momento, secondo lo schema qui riportato, cambiando di posto la guarnizione collocata sotto a uno dei due tappi avvitati nel corpo.  
 The function of the valve can be changed by repositioning the seal situated under one of the two plugs.



## 5 VIE - 5 WAYS

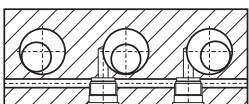
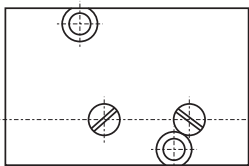
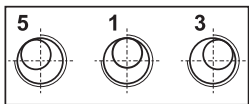
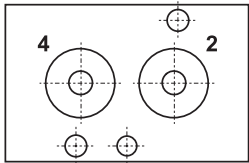

tappo senza guarnizione  
plug without seal

tappo con guarnizione  
plug with seal

## 3 VIE - 3 WAYS

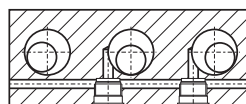
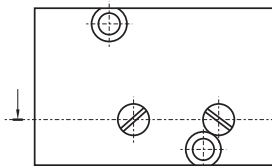
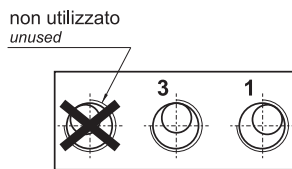
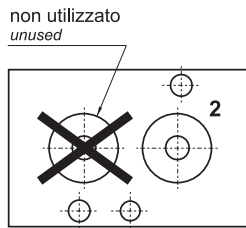

tappo con guarnizione  
plug with seal

tappo senza guarnizione  
plug without seal

### Materiali

**Corpo:** alluminio 11S

**Comando e fondello:** tecnopolimero (\*)

**Molle:** INOX

**Guarnizioni:** NBR

**Spola:** alluminio nichelato

**Parti interne:** ottone OT58

### Materials

**Body:** aluminium 11S

**End caps:** technopolymer (\*)

**Springs:** stainless steel

**Seals:** NBR

**Spool:** nickel plated aluminium

**Internal parts:** brass OT58

(\*) Su richiesta e dietro supplemento di prezzo, le valvole sono fornibili con corpo, comando e fondello interamente in alluminio. Alcune valvole, come di seguito specificato, sono disponibili solo nella versione in alluminio. Le valvole ATEX sono solo in alluminio.

Le parti in tecnopolimero recano impresso il logo

(\*) On request and upon extra charge, the valves are available also with body and end caps entirely in aluminium. Some valves, as specified in the next pages, are available only in the aluminium version. ATEX valves are only in aluminium.

The parts in technopolymer are marked with the logo

I prodotti di seguito indicati sono venduti senza bobine, da acquistarsi separatamente (vedi pag. 322-323).

The following listed products are sold without coils, which are bought separately (refer to pages 322-323).

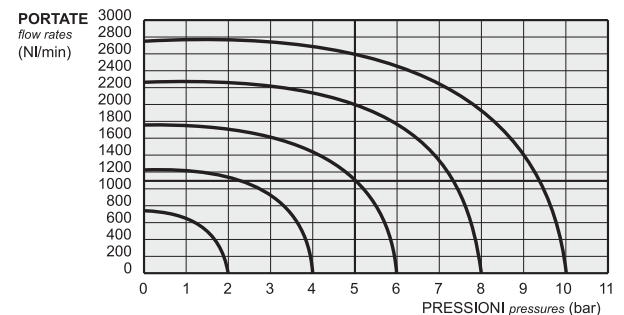

### Kit ricambi - spare parts

**01.065.2** : per valvole [for valves] 382 MC, 382 ME, 582 MC, 582 ME

**01.066.2** : per valvole [for valves] 382 CC, 382 EE, 582 CC, 582 EE

Diametro nominale Nominal orifice		7.5 mm		
Attacchi Ports		G1/4"		
Temperatura di esercizio Temperature range		max +60°C		
Pressione di esercizio Working pressure	el. monost. [electr. monost.]	el. bistabile [electr. bi-stable]	pn. monost. [pneum. monost.]	pn. bistabile [pneum. bist.]
	2.5 ... 10 bar 0.25 ... 1 MPa	1 ... 10 bar 0.1 ... 1 MPa	0 ... 10 bar 0 ... 1 MPa	0 ... 10 bar 0 ... 1 MPa
Pressione di azionamento Actuating pressure			pn. monost. [pneum. monost.]	pn. bistabile [pneum. bist.]
			2.5 ... 10 bar 0.25 ... 1 MPa	1 ... 10 bar 0.1 ... 1 MPa
Fluido Fluid		Aria filtrata 50µ con o senza lubrificazione 50µ filtered, lubricated or non lubricated air		

# valvole Namur

Namur valves



## 382 MC

3/2 NC comando pneumatico - ritorno a molla  
3/2 NC pneumatic pilot - spring return

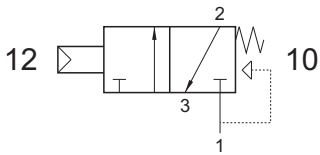

## 582 MC

5/2 comando pneumatico - ritorno a molla  
5/2 pneumatic pilot - spring return

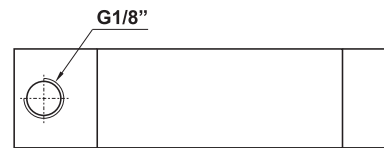
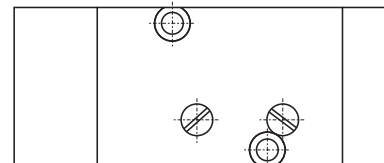
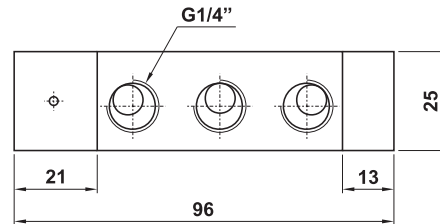
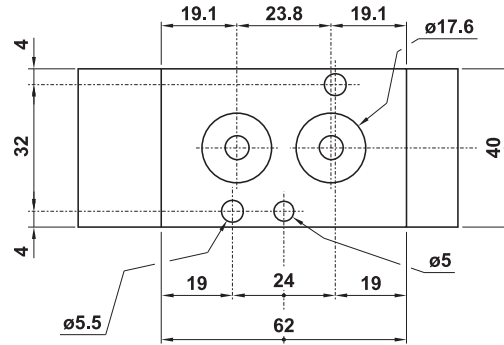
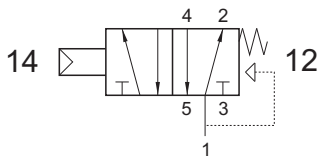

## 382 CC

3/2 doppio comando pneumatico  
3/2 double pneumatic pilot

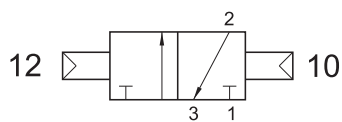

## 582 CC

5/2 doppio comando pneumatico  
5/2 double pneumatic pilot

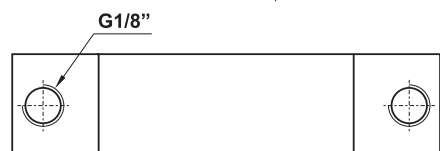
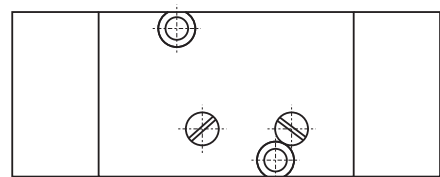
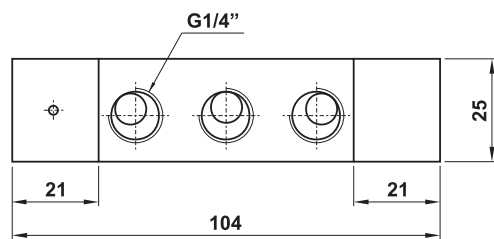
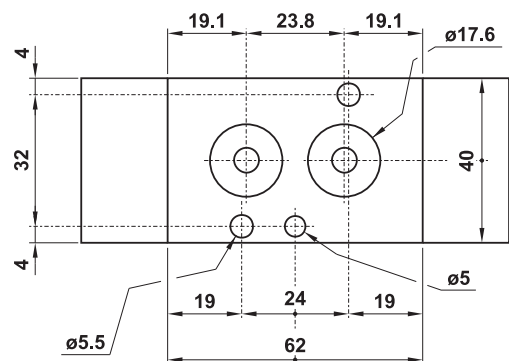
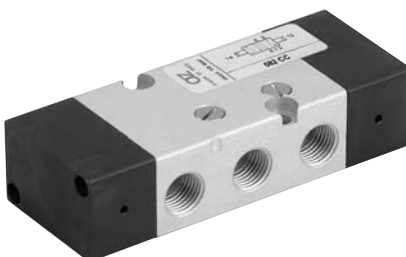
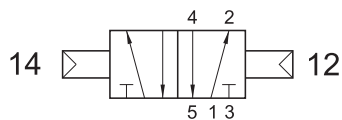

# valvole Namur

Namur valves



## 382 ME

3/2 NC comando elettrico - ritorno a molla

3/2 NC solenoid pilot - spring return

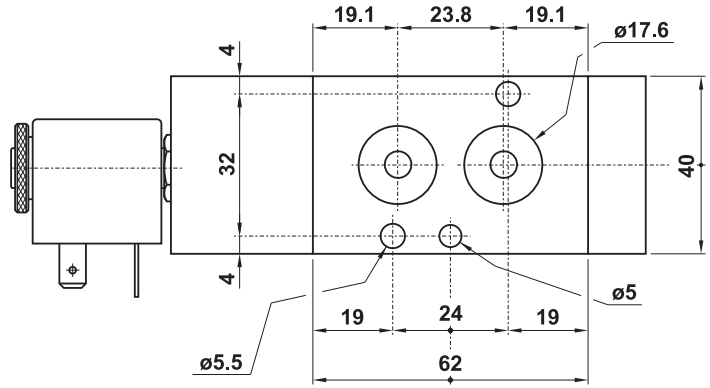
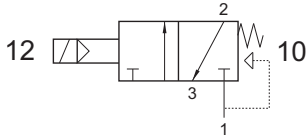

## 582 ME

5/2 comando elettrico - ritorno a molla

5/2 solenoid pilot - spring return

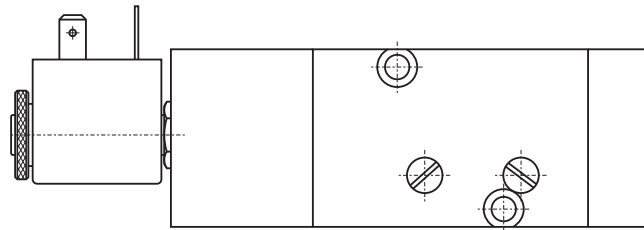
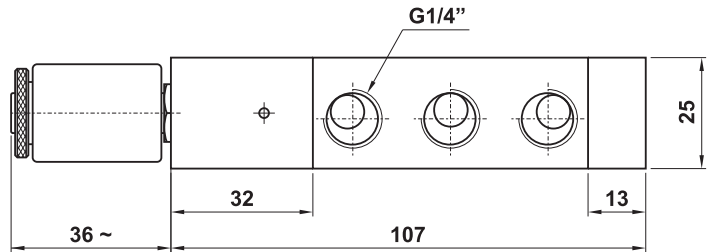
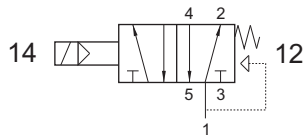

## 382 EE

3/2 doppio comando elettrico

3/2 double solenoid pilot

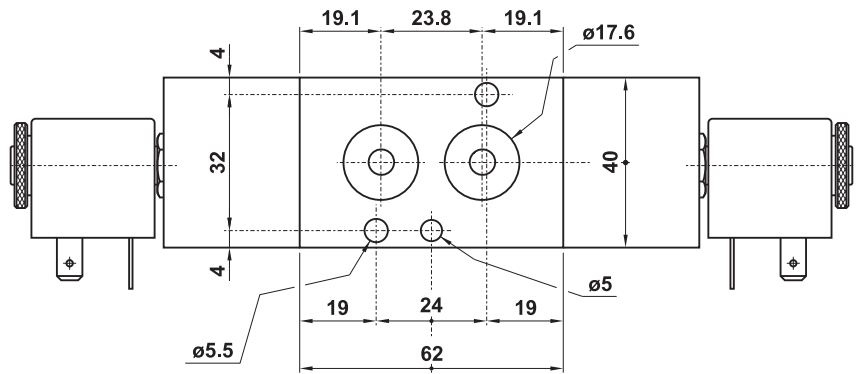
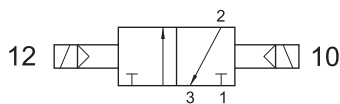

## 582 EE

5/2 doppio comando elettrico

5/2 double solenoid pilot

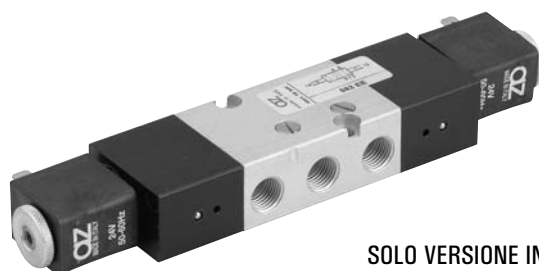
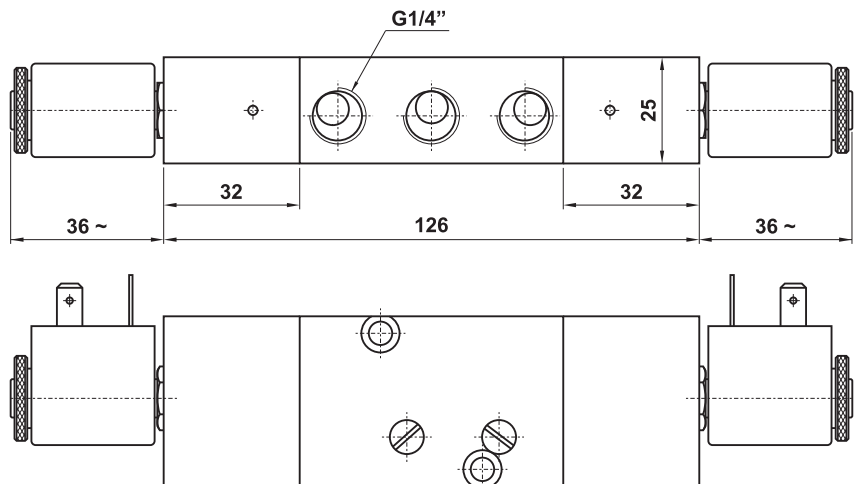
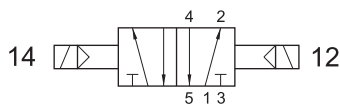

SOLO VERSIONE IN ALLUMINIO  
ONLY ALUMINIUM VERSION

## 382 MRE

3/2 NC comando elettrico - ritorno a molla FONDELLO RINFORZATO

3/2 NC solenoid pilot - REINFORCED spring return

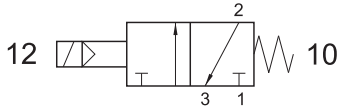

Non può essere utilizzata come valvola normalmente aperta.  
It cannot be used as normally open valve.

## 582 MRE

5/2 comando elettrico - ritorno a molla FONDELLO RINFORZATO

5/2 solenoid pilot - REINFORCED spring return

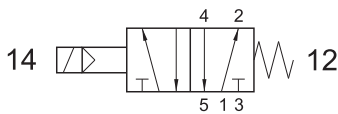

Pressione di esercizio: 2.5 ... 10 bar

Working pressure: 2.5 ... 10 bar

La molla rinforzata permette un ritorno efficace della spola anche in assenza di aria.

The reinforced spring allows a prompt return of the spool also in lack of air.

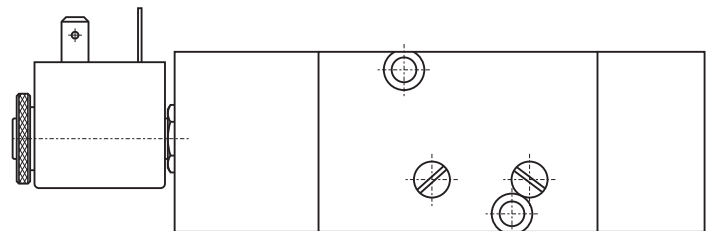
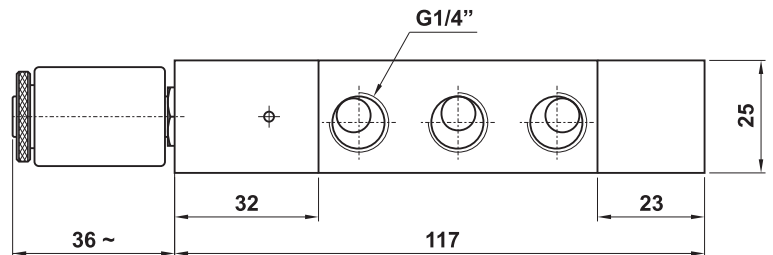
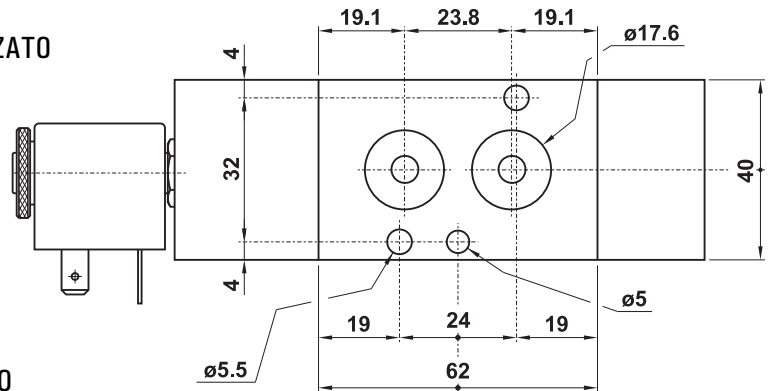

adattatore per bobina 30 mm  
e bobina ATEX  
adapter for 30 mm coil  
and ATEX coil

CODICE DI ORDINAZIONE  
ORDER CODE

01.055.2



Questo adattatore deve essere montato sotto a una valvola Namur per sollevarla e consentire l'uso di una bobina da 30 mm.

This adaptor must be mounted under a Namur valve to create the installation space for a 30 mm coil.

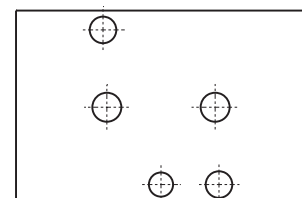
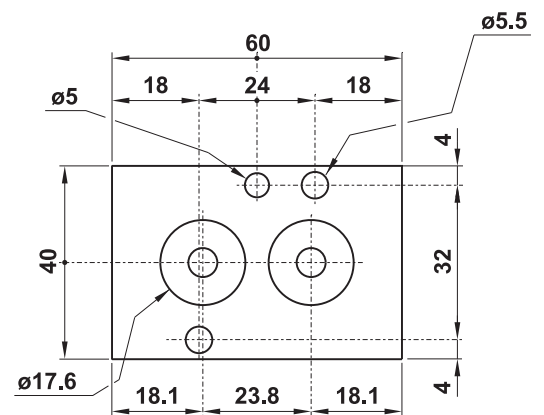

# valvole Namur

Namur valves



**5823C EE**

centri chiusi  
*closed centres*

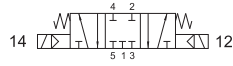

**5823A EE**

centri aperti  
*open centres*

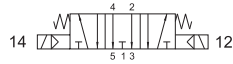

**5823P EE**

centri in pressione  
*pressurized centres*

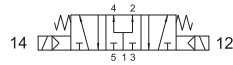

5/3 1/4" doppio comando elettrico

5/3 1/4" double solenoid pilot

SOLO VERSIONE IN ALLUMINIO

ONLY ALUMINIUM VERSION

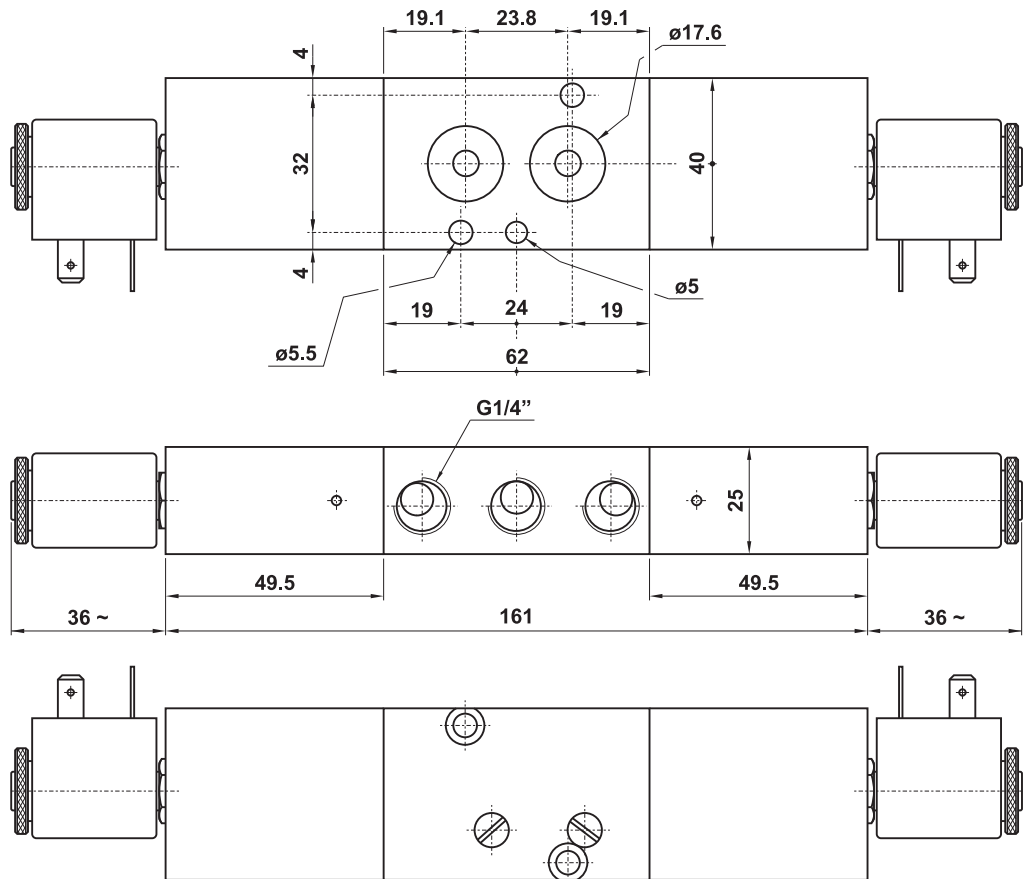

2

## 01.202.3

Elettrovalvola **NAMUR** multifunzione con sede sensore  
*multifunction NAMUR solenoid valve with slot for magnetic sensor*

Questa elettrovalvola NAMUR può essere utilizzata come 5/2, 3/2 NC, 3/2 NA, 2/2 NC, 2/2 NA senza dovere effettuare regolazioni o modifiche sul corpo valvola o inserire adattatori.

*This NAMUR solenoid valve can be used as 5/2, 3/2 NC, 3/2 NO, 2/2 NC, 2/2 NO without setting or modifying anything in the valve body and without inserting any adaptor.*

5/2

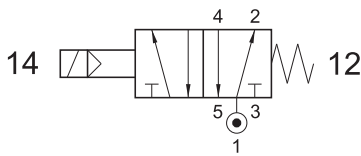

2/2 NC

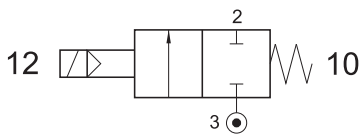

2/2 NA [2/2 NO]

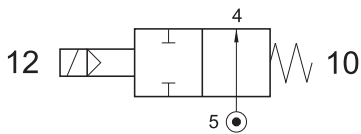

3/2 NC

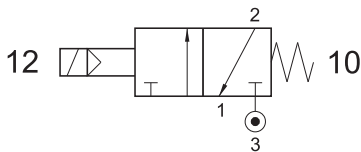

3/2 NA [3/2 NO]

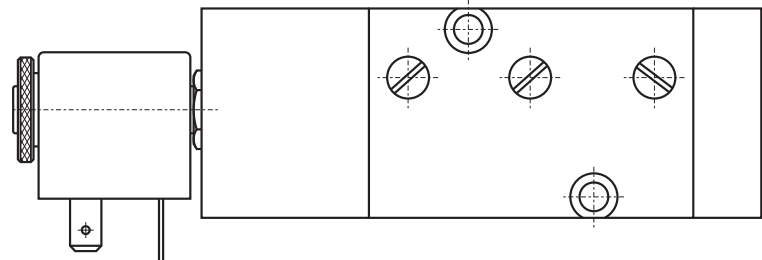
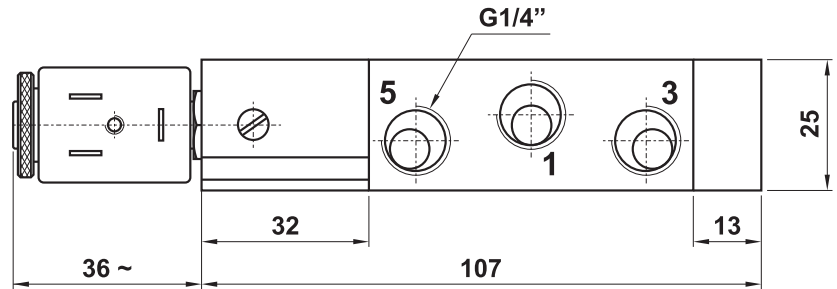
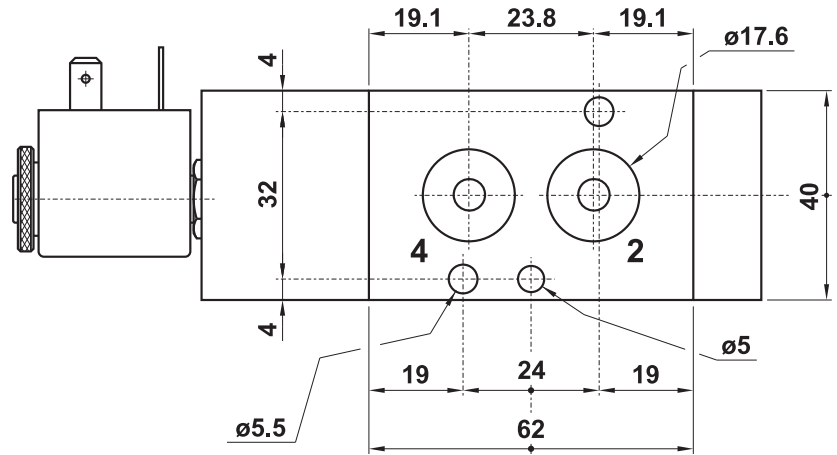
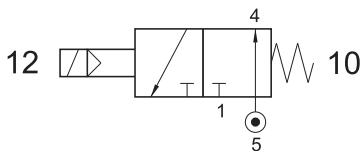

I prodotti qui indicati sono venduti senza bobine, da acquistarsi separatamente.  
*All here mentioned products are sold without coils, which are bought separately.*

La valvola è fornita con la sede sensore, la quale può essere utilizzata o no a seconda dei casi. Non è prevista la versione senza sede sensore.  
*The valve is supplied with the sensor slot, which can be used or not depending on the case. The version without sensor slot is not provided.*



# bobine e connettori 22 mm

22 mm coils and connectors



22 mm



temperatura max di esercizio	+50°C	max working temperature
inserimento	ED 100%	duty cycle
protezione con connettore correttamente montato	IP 65	protection with connector correctly mounted
tolleranza di tensione	±10%	tension tolerance

- a richiesta basso assorbimento 1.5W  
low consumption (1.5W) on request

codice code	tensione tension	consumo - power	
		a regime rated	di spunto inrush
00.167.0	12V DC	3W	
00.028.0	24V DC	3W	
00.029.0	24V 50/60Hz	5VA	7.5VA
00.030.0	110V 50/60Hz	5VA	7.5VA
00.031.0	220V 50/60Hz	5VA	7.5VA

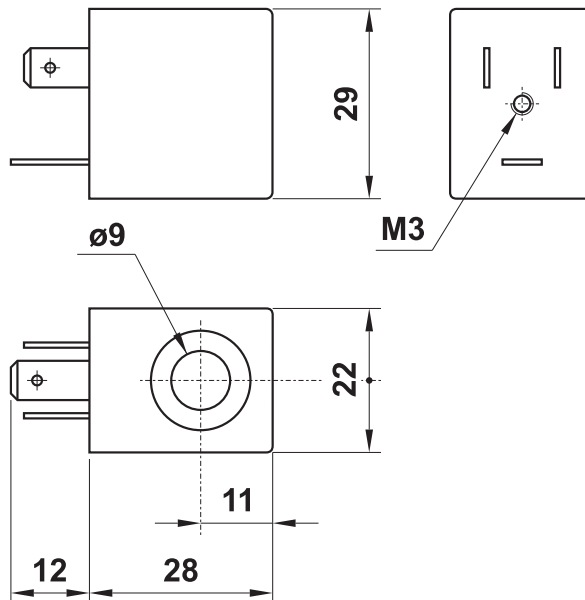

codice code	colore colour	cavo cable	tipo type
00.197.0	nero black	PG09	normale standard
00.344.0	trasparente transparent	PG09	con LED 24V with LED 24V
00.345.0	trasparente transparent	PG09	con LED 24V e VDR with LED 24V and VDR
00.346.0	trasparente transparent	PG09	con LED 115V with LED 115V
00.347.0	trasparente transparent	PG09	con LED 115V e VDR with LED 115V and VDR
00.394.0	trasparente transparent	PG09	con LED 230V with LED 230V
00.395.0	trasparente transparent	PG09	con LED 230V e VDR with LED 230V and VDR

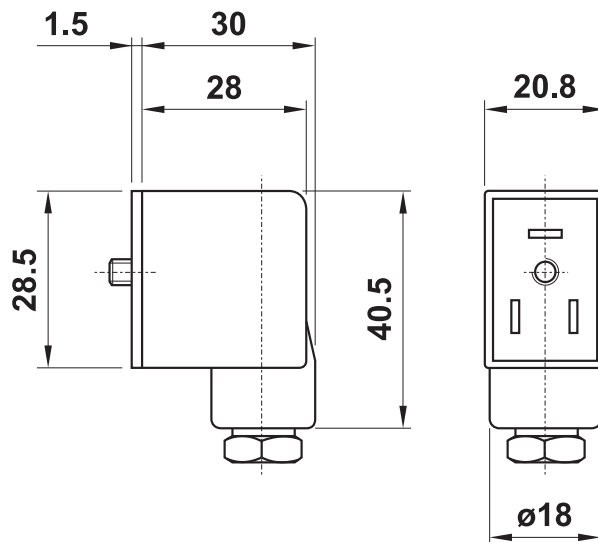

### PEZZI DI RICAMBIO - spare parts

<p>canotto per elettropilota armature for solenoid pilot</p> <p>NC : 00.088.0 NA (NO) : 00.306.0</p>	<p>ghiera in alluminio e rondella aluminium nut and elastic ring</p> <p>00.125.2</p>
	<p>ghiera in plastica nut in plastic material</p> <p>00.186.0</p>

# bobine e connettori 30 mm

30 mm coils and connectors



30 mm

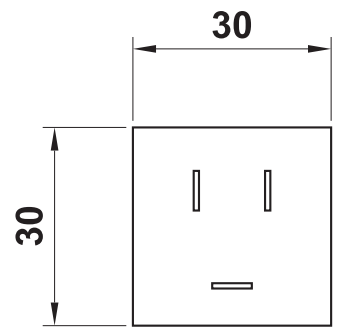

temperatura max di esercizio	+50°C	max working temperature
inserimento	ED 100%	duty cycle
protezione con connettore correttamente montato	IP 65	protection with connector correctly mounted
tolleranza di tensione	±10%	tension tolerance

codice code	tensione tension	consumo - power	
		a regime rated	di spunto inrush
00.258.0	24V DC	2W	
00.259.0	24V 50/60Hz	5VA	9VA
00.260.0	110V 50/60Hz	5VA	9VA
00.261.0	220V 50/60Hz	5VA	9VA

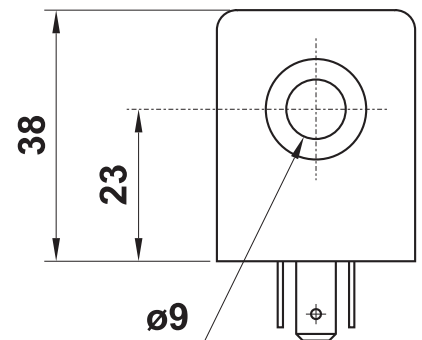

Per montare questo tipo di bobine sulle valvole Namur occorre acquistare il distanziale 01.055.2 (pag. 319) che deve essere montato sotto la valvola, in modo da alzarla creando lo spazio necessario alla bobina da 30 mm.

The adaptor kit 01.055.2 (page 319) is necessary to assemble this coil on Namur valves.

codice code	colore colour	cavo cable	tipo type
00.251.0	nero black	PG09	normale standard
00.355.0	trasparente transparent	PG09	con LED e protezione Transil 24V with LED and Transil protection 24V
00.350.0	trasparente transparent	PG09	con LED 115V with LED 115V
00.351.0	trasparente transparent	PG09	con LED 115V e VDR with LED 115V and VDR
00.396.0	trasparente transparent	PG09	con LED 230V with LED 230V
00.397.0	trasparente transparent	PG09	con LED 230V e VDR with LED 230V and VDR

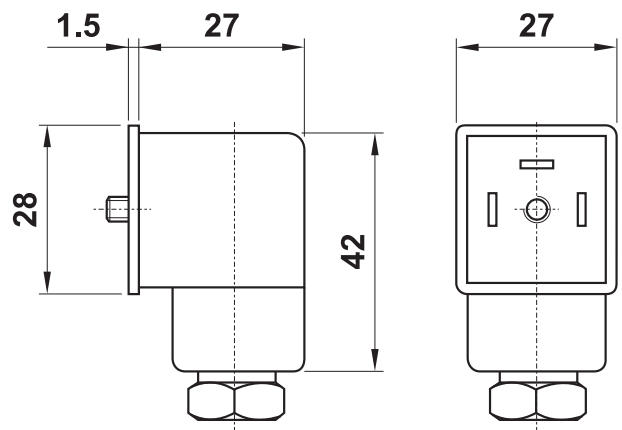

## PEZZI DI RICAMBIO - spare parts

<p>canotto per elettropilota armature for solenoid pilot</p> <p>NC : 00.088.0 NA (NO) : 00.306.0</p>	<p>ghiera in alluminio e rondella aluminium nut and elastic ring</p> <p>00.125.2</p>
	<p>ghiera in plastica nut in plastic material</p> <p>00.186.0</p>