

UW-10~50

UD Series

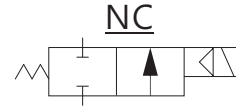
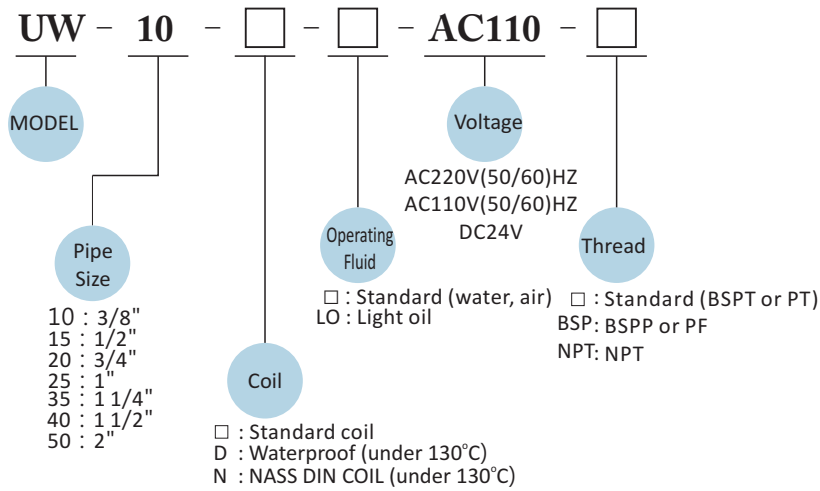

PRODUCT DESCRIPTION

- UW series is direct, multiplex, connected diaphragm, conductive and normally closed (NC) 2/2 way solenoid valve.
- Able to operate under low pressure
- Applied fluid type : water, air, light oil
- Acceptable for customization Viton (130°C) , Silicone (130°C) and EPDM (130°C) for seal plug and diaphragm

CAUTIONS:

- Before pipelining, the pipe line must be very clean without any contaminants or impurity.
- To extend the lifetime, Y-line filter should be installed in the front end of solenoid valve.
- AC voltage tolerance: ± 10%; DC voltage tolerance: ± 1%
- It should be installed horizontally; vertical installation is not advisable.

Not Suitable For Fluid As Below:

- Liquid status when it is in high temperature; solid status when it is in low temperature.
- Corrosive fluid
- Viscosity over 20cst

MATERIAL:

PARTS	Coil	Tube	Spring	Core	Plug	Diaphragm	Valve body
MATERIAL	Special copper wire (H class)	Stainless steel	Stainless steel	Stainless steel	NBR	NBR	Forged Brass

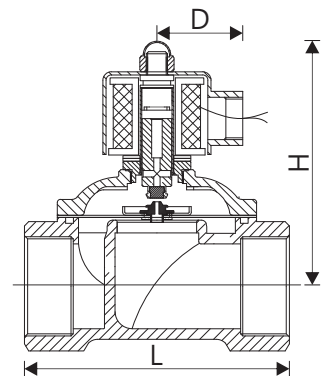

SPECIFICATION

MODEL	Waterproof DIN/flying lead Coil	NASS DIN Coil (IP65)	PIPE SIZE	CV	ORIFICE	FLUID TEMP. (°C)	Operating Pressure kgf / cm ² (bar)			High Pressure Type		Dimension (mm)			Weight (kg)
							Water	Air	Light oil	Water	Air	L	H	D	
UW-10	●	●	3/8"	4.5	15mm	-5°C ~ +80°C	0~5	0~7	0~5	0.5~10	0.5~20	70	100	48	1.01
UW-15	●	●	1/2"	4.5	15mm	-5°C ~ +80°C	0~5	0~7	0~5	0.5~10	0.5~20	70	100	48	1
UW-20	●	●	3/4"	8.6	20mm	-5°C ~ +80°C	0~5	0~7	0~5	0.5~10	0.5~20	73	107	48	1.14
UW-25	●	●	1"	12	25mm	-5°C ~ +80°C	0~5	0~7	0~5	0.5~10	0.5~20	100	112	48	1.7
UW-35	●		1 1/4"	24	35mm	-5°C ~ +80°C	0~5	0~7	0~5	0.5~10	0.5~20	125	113	48	2.32
UW-40	●		1 1/2"	28	40mm	-5°C ~ +80°C	0~5	0~7	0~5	0.5~10	0.5~20	125	118	48	2.53
UW-50	●		2"	48	50mm	-5°C ~ +80°C	0~5	0~7	0~5	0.5~10	0.5~20	167	125	48	4.32

● High Pressure Type Use N/O Coil