

## WAFER BUTTERFLY VALVE



CREATIVE • INNOVATION • PROCESS



SKU:0100



Scan me

## WAFER BUTTERFLY VALVE

### Description

Wafer butterfly valves with epoxy-coated ductile iron body are designed to control various media in commercial and industrial applications. Valve mounts between two standard ANSI 125/150, DIN PN10/16 and other international flanges. Seat to flange seal, eliminates the need for flange gaskets. Disc is precision machined 1.4408 (CF8M). Two piece stem and disc design enhances the flow capacity and reduces turbulence.

### Features

- ISO5211 top mounting for manual, air or electric actuators
- Unique hard/soft seat reduces torque and extends seal life
- Ductile iron body with epoxy coating
- 316SS disc with 2-piece stem design enhances flow capacity
- EPDM, NBR (Buna-N), FPM, PTFE or VMQ seal options
- PTFE graphite reinforced stem bearings
- Pressure rated 230 PSI (16 Bar)
- Multi-standard flanged mounting holes
- Optional 10 position locking hand lever

### Application

Wafer body butterfly valves are used to control the flow of water, oils, air, vacuum and other media compatible with the materials of construction. Valves can be operated with manual, air or electric actuators.

Four seal options are available :

EPDM, NBR (Buna-N), FPM, PTFE, VMQ

### Operation

Direct mount wafer butterfly valves can be easily fitted with optional manual operator, air actuator or electric actuator using standard ISO5211 top mounting. Rotating the square stem one quarter turn moves the stainless steel disc and open or closes the valve. Unique soft seat reduces the torque required to close the valve and extends the seal life.

### Temperature Range

**EPDM:** -20 to 120°C, **Buna-N:** -15 to 85°C, **FKM:** -15 to 200°C, **MQ:** -30 to 200°C, **PTFE:** -20 to 200°C

### Options

- Hand lever with 10 position locking
- Gear Box
- Air Actuators
- Electric Actuators

### Materials

Valve Body	Epoxy coated ductile iron GGG40
Disc	1.4408 stainless steel (CF8M)
Disc Seat Options	EPDM, NBR (Buna-N), FKM, VMQ, PTFE
Stem Seals	O-ring (same material as seat)
Stem	420SS
Bearings	PTFE Graphite reinforced
Fasteners	Stainless Steel

Specifications

DIM	KV-VALUE RATED FLOW COEFFICIENT (M <sup>3</sup> /H AT 1 BAR ΔP)									
[MM]	MAX TORQUE [NM]	10°	20°	30°	40°	50°	60°	70°	80°	90°
DN50	12	<1	<1	5	14	29	47	71	98	107
DN65	17	1	2	11	27	50	77	122	171	213
DN80	24	3	6	28	54	91	140	213	301	404
DN100	35	5	14	57	108	175	262	404	594	799
DN125	59	6	27	84	156	248	385	624	954	1239
DN150	84	7	51	129	224	363	572	977	1535	1929
DN200	164	22	114	229	401	639	1018	1755	2880	3484
DN250	280	33	171	334	634	970	1530	2650	4403	5753
DN300	386	49	250	490	925	1416	2231	3865	6641	8828
DN350	700	118	301	631	1131	1918	3081	4963	8884	10308
DN400	850	153	393	824	1478	2506	4024	6482	11603	13464
DN450	1497	195	498	1043	1871	3170	5093	8210	14686	17041
DN500	1988	240	615	1288	2309	3913	6287	10128	18130	21038
DN600	3264	345	885	1853	3326	5635	9054	14584	26109	30295

Above mentioned torques are based on on/off services/lubricating liquid.

VALVE SIZING

Determining the size of butterfly valves for control purposes should not be done on the basis of the nominal diameter of the pipe but should be calculated on the basis of the operating characteristics in order to attain the correct control characteristics.

Convalve Butterfly valves are designed with approximately equal percentage characteristics over an opening angle of 65°.

You only need to consider the opening angle when determining the size of control valves. When determining the valve nominal diameter calculate the Kv value from the below

Liquid:

$$K_v = Q \times \sqrt{\frac{W}{\Delta S}}$$

Gas:

$$K_v = \frac{V_N}{514} \sqrt{\frac{G \times T}{\Delta S \cdot P_d}}$$

- KV = Flow coefficient
- Q = Max. flow volume in m<sup>3</sup>/h
- w = Exact weight in kg/m<sup>3</sup>
- ΔS = Pressure drop in bar
- VN = Max. flow in Nm<sup>3</sup>/h
- G = Exact weight in kg/Nm<sup>3</sup>
- T = Absolute temp. in ° Kelvin
- Pd = Absolute pressure downstream in bar

Example: DN 100

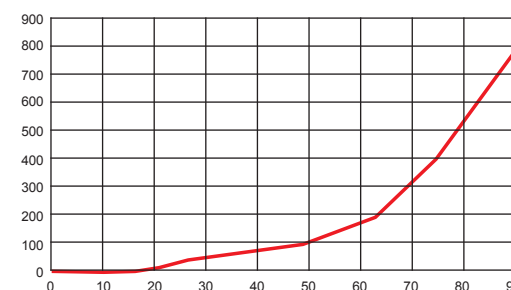

Valve Structure: Soft Seal 50-150

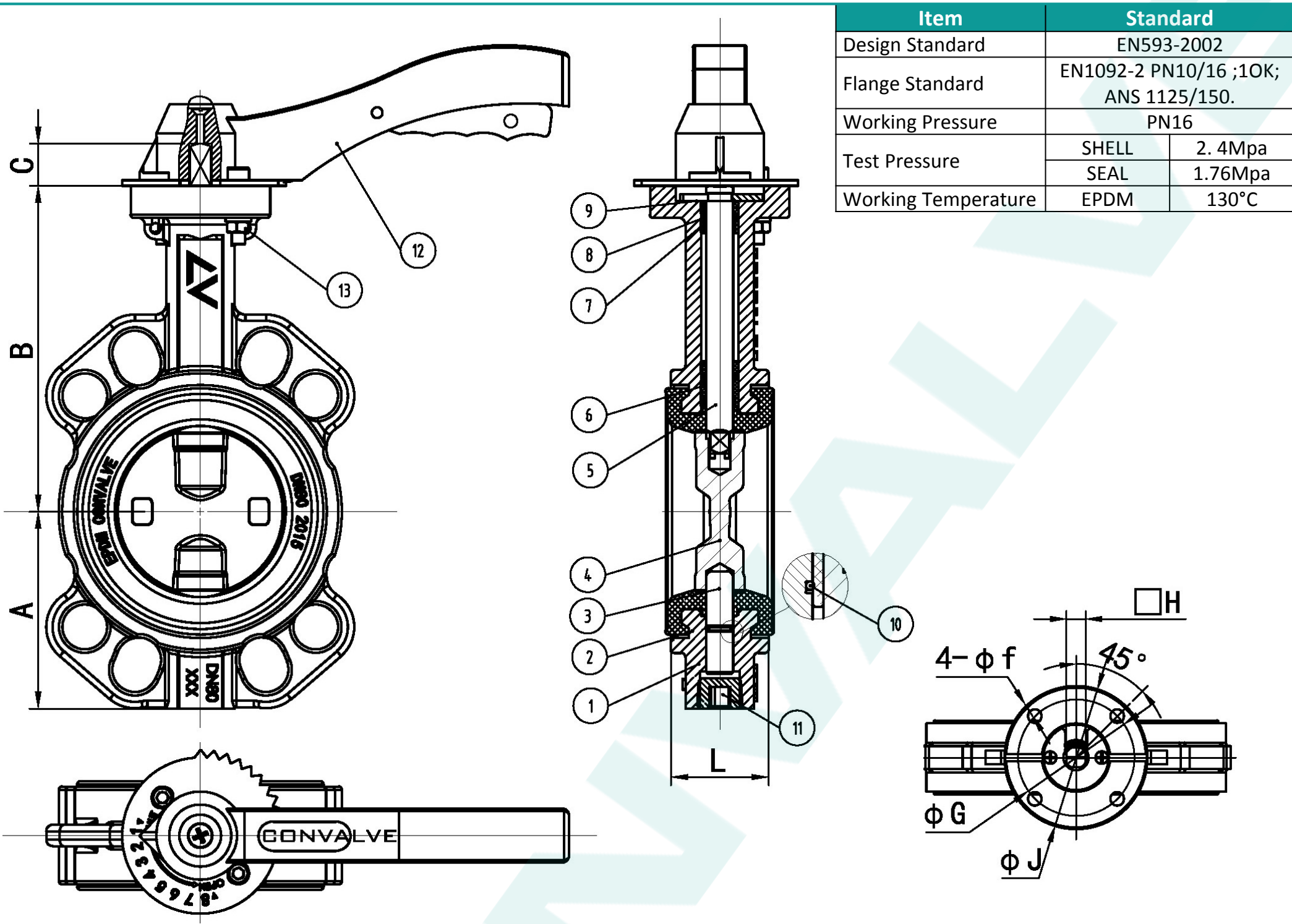

Item	Standard	
Design Standard	EN593-2002	
Flange Standard	EN1092-2 PN10/16 ;10K; ANS 1125/150.	
Working Pressure	PN16	
Test Pressure	SHELL	2.4Mpa
	SEAL	1.76Mpa
Working Temperature	EPDM	130°C

Size	A	B	C	L	ΦG	ΦJ	4 - ΦF	□H
DN50	66	126	14	43	65	50	4-7	9X9
DN65	87	133	14	46	65	50	4-7	9X9
DN80	92	152	14	46	65	50	4-7	9X9
DN100	107	170	15	52	90	70	4-10	11X11
DN125	121	181	17	56	90	70	4-10	14X14
DN150	132	196	17	56	90	70	4-10	14X14

No	Part name	Materials
1	Body	GGG40
2	Seat	EPDM
3	Down shaft	ASTM A276 / 416
4	Disc	1.4308 / 1.4408
5	Upper shaft	ASTM A276 / 416
6	Bushing (Long)	RPTFE
7	Bushing (Short)	RPTFE
8	O-Ring	EPDM
9	Washer	Carbon steel
10	O-Ring	EPDM
11	Plug	MI
12	Handle	AL
13	Bolt/Nut	Stainless steel

Valve Structure: Soft Seal 200-300

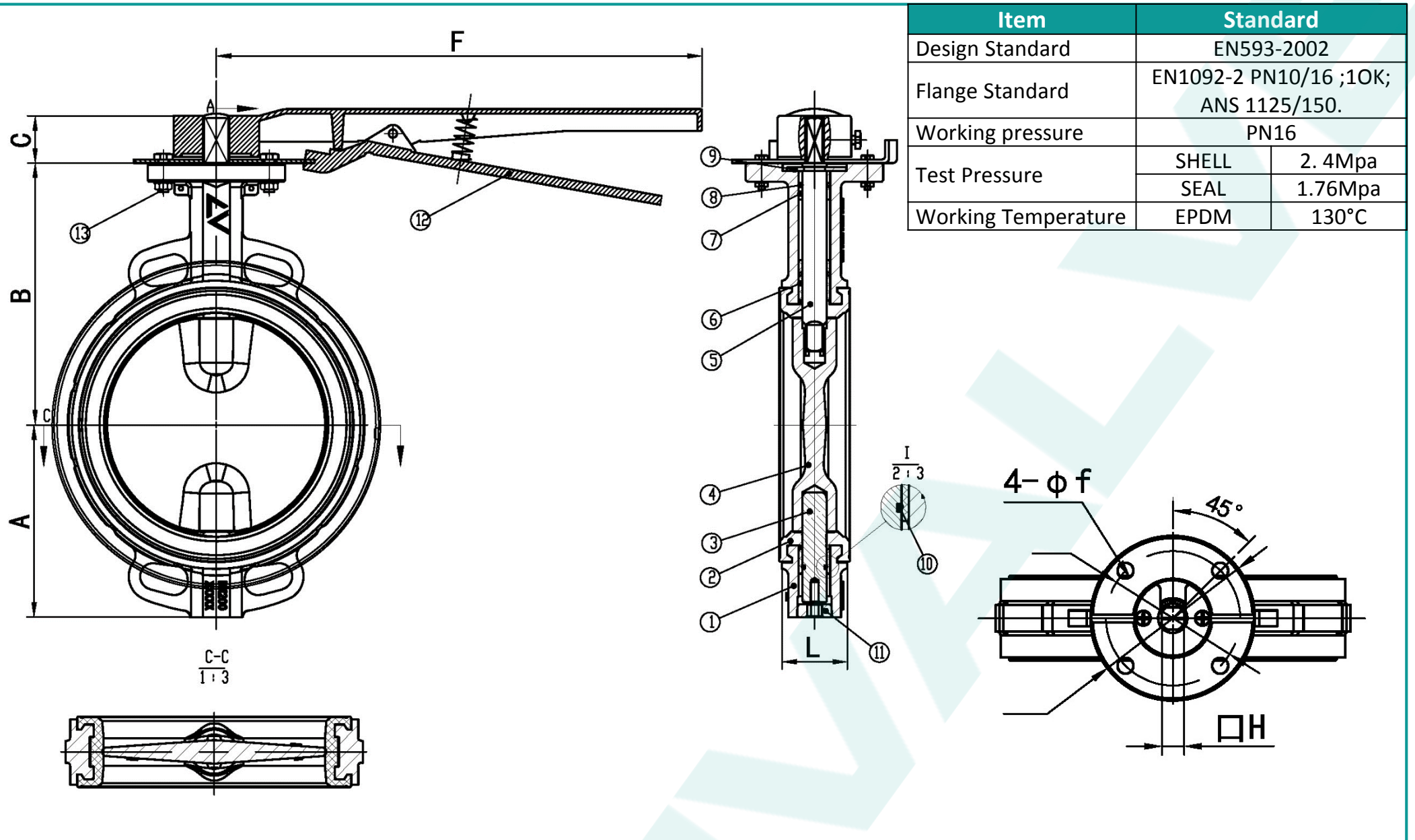

Item	Standard	
Design Standard	EN593-2002	
Flange Standard	EN1092-2 PN10/16 ;10K; ANS 1125/150.	
Working pressure	PN16	
Test Pressure	SHELL	2.4Mpa
	SEAL	1.76Mpa
Working Temperature	EPDM	130°C

Size	A	B	F	C	L	ΦG	ΦJ	4 - ΦF	□H
DN200	175	238	358	30	60	25	102	4-12	17X17
DN250	198	258	358	39	68	25	102	4-12	22X22
DN300	243	300	358	39	78	25	102	4-12	22X22

No	Part name	Materials
1	Body	GGG40
2	Seat	EPDM
3	Down shaft	ASTM A276 / 416
4	Disc	1.4308 / 1.4408
5	Upper shaft	ASTM A276 / 416
6	Bushing (Long)	RPTFE
7	Bushing (Short)	RPTFE
8	O-Ring	EPDM
9	Washer	Carbon steel
10	O-Ring	EPDM
11	Plug	MI
12	Handle	MI
13	Bolt/Nut	Stainless steel

Valve Structure: Soft Seal 350-600

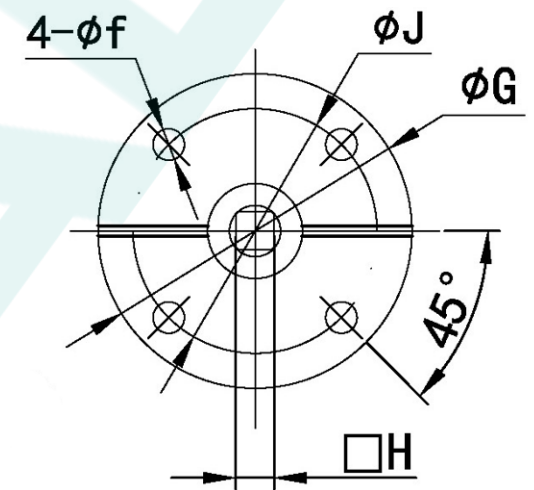
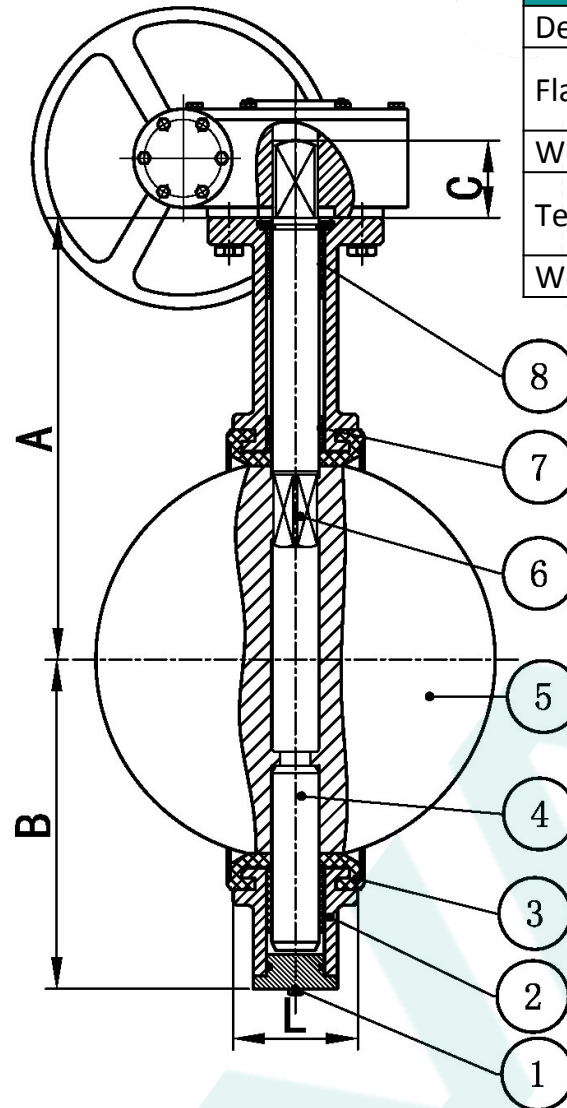
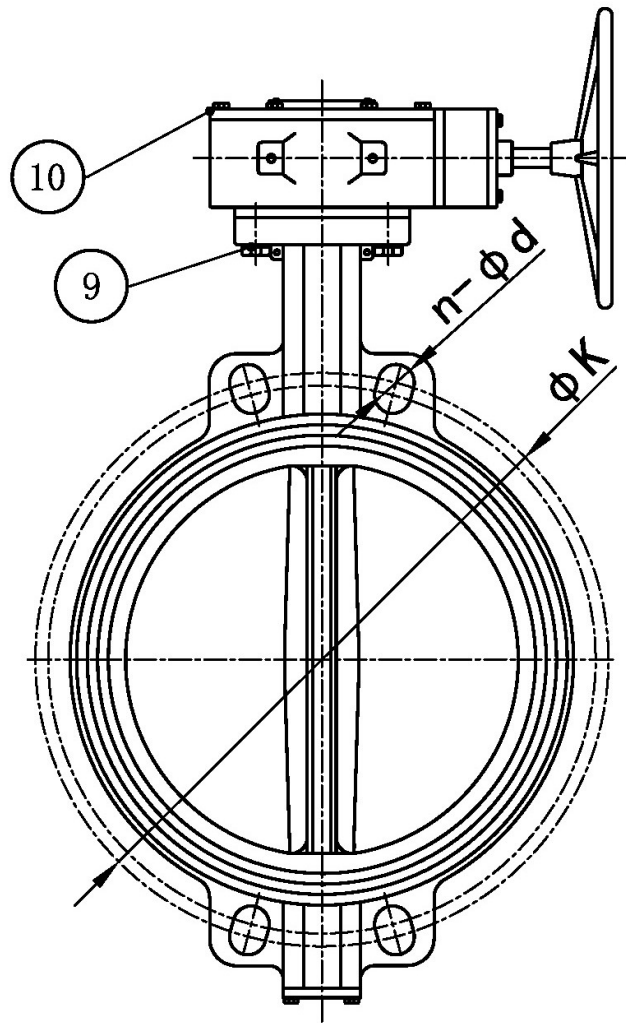

Item	Standard	
Design Standard	EN593-2002	
Flange Standard	EN1092-2 PN10/16 ;10K; ANS 1125/150.	
Working Pressure	PN16	
Test Pressure	SHELL	2.4Mpa
	SEAL	1.76Mpa
Working Temperature	EPDM	130°C

Size	A	B	C	L	φG	φJ	4 - φF	□H	PN10		PN16		CLASS 125/150	
									φK	n-φd	φK	n-φd	φK	n-φd
DN350	346	262	43	78	150	125	4-14	22X22	460	16-23	470	16-27	476.2	12-29
DN400	375	293	49	102	175	140	4-19	27X27	515	16-28	525	16-30	539.7	16-29
DN450	400	325	49	114	175	140	4-19	27X27	565	20-28	585	20-30	577.9	16-32
DN500	432	358	62	127	210	165	4-23	36X36	620	20-28	650	20-33	635	20-32
DN600	562	444	68	154	210	165	4-23	36X36	725	20-31	770	20-33	749.3	20-35

No	Part name	Materials
1	Stub	GGG40
2	Body	GGG40
3	Seat	EPDM
4	Down shaft	ASTM A276 / 416
5	Disc	1.4308 / 1.4408
6	Upper shaft	ASTM A276 / 416
7	Bushing	RPTFE
8	O-Ring	EPDM
9	Bolt	Stainless steel
10	Gear Box	GGG40

Valve Structure: Hard Seal 50-150

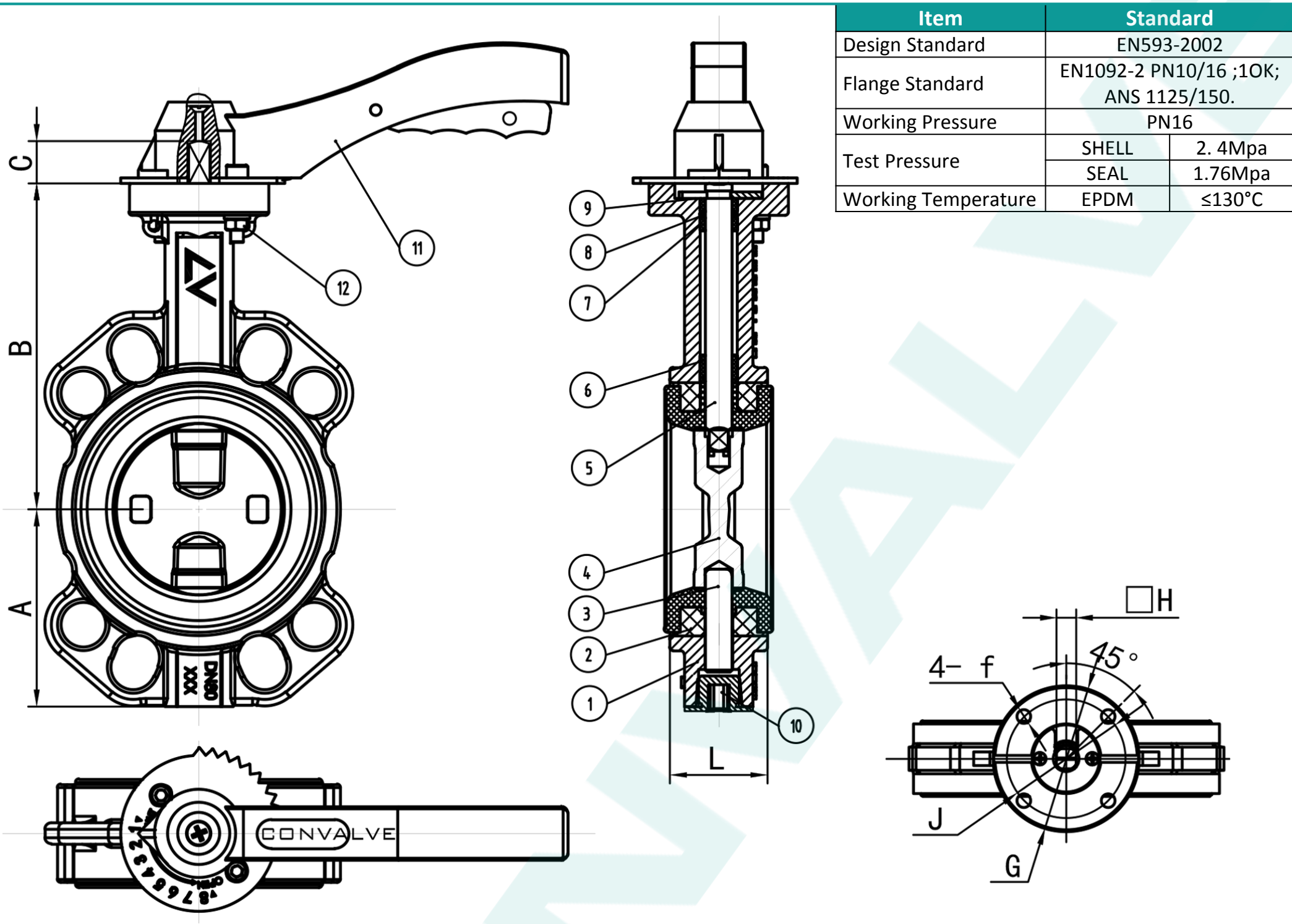

Item	Standard	
Design Standard	EN593-2002	
Flange Standard	EN1092-2 PN10/16 ;10K; ANS 1125/150.	
Working Pressure	PN16	
Test Pressure	SHELL	2.4Mpa
	SEAL	1.76Mpa
Working Temperature	EPDM	≤130°C

Size	A	B	C	L	ΦG	ΦJ	4 - ΦF	□H
DN50	66	126	14	43	65	50	4-7	9X9
DN65	87	133	14	46	65	50	4-7	9X9
DN80	92	152	14	46	65	50	4-7	9X9
DN100	107	170	15	52	90	70	4-10	11X11
DN125	121	181	17	56	90	70	4-10	14X14
DN150	132	196	17	56	90	70	4-10	14X14

No	Part name	Materials
1	Body	GGG40
2	Seat	EPDM
3	Down shaft	ASTM A276 / 416
4	Disc	1.4308 / 1.4408
5	Upper shaft	ASTM A276 / 416
6	Bushing (Long)	RPTFE
7	Bushing (Short)	RPTFE
8	O-Ring	EPDM
9	Washer	Carbon steel
10	Plug	MI
11	Handle	AL
12	Bolt/Nut	Stainless steel

Valve Structure: Hard Seal 200-300

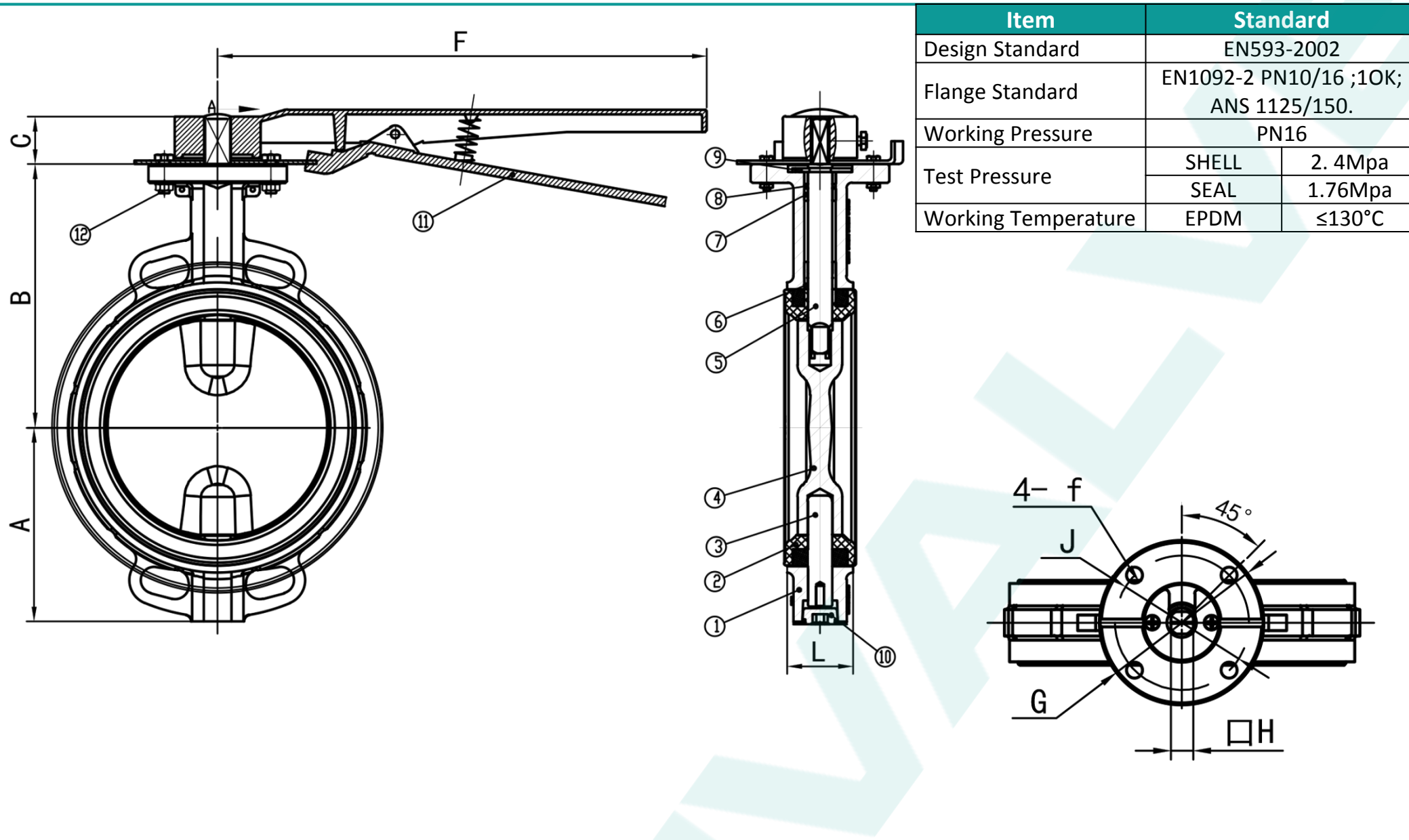

Item	Standard	
Design Standard	EN593-2002	
Flange Standard	EN1092-2 PN10/16 ;10K; ANS 1125/150.	
Working Pressure	PN16	
Test Pressure	SHELL	2.4Mpa
	SEAL	1.76Mpa
Working Temperature	EPDM	≤130°C

Size	A	B	F	C	L	ΦG	ΦJ	4 - ΦF	□H
DN200	175	238	358	30	60	25	102	4-12	17X17
DN250	198	258	358	39	68	25	102	4-12	22X22
DN300	243	300	358	39	78	25	102	4-12	22X22

No	Part name	Materials
1	Body	GGG40
2	Seat	EPDM
3	Down shaft	ASTM A276 416
4	Disc	1.4308 / 1.4408
5	Upper shaft	ASTM A276 416
6	Bushing (Long)	RPTFE
7	Bushing (Short)	RPTFE
8	O-Ring	NBR
9	Washer	Carbon steel
10	Plug	MI
11	Handle	MI
12	Bolt/Nut	Stainless steel