

HART® Field Device Specification

Fisher™ FIELDVUE™ DVC5000 Digital Valve Controllers

HART Revision	Device Type	Device Revision	Firmware Revision
HART 5	02	2	3, 4
		3	5, 6

- Introduction 2
- Product Overview 2
- Purpose of this document 2
- Abbreviations and definitions 2
- Reference Documentation 3
- Device Identification 3
- Product Interfaces 4
- Control Valve Interface 4
- Host interface 4
- Internal Jumpers And Switches 5
- Write Protection 5
- Firmware Upgrade 5
- Dynamic Variables 6
- Device Variables 6
- Status Information 7
- Device Status 7
- Universal Commands 8
- Common-Practice Commands 13
- Supported Commands 13
- Device-Specific Commands 21
- Burst Mode 21
- Catch Device Variable 21
- Performance 21
- Annex A Compatibility Checklist 22
- Annex B DVC5000 Parameters as part
of a Rosemount® 1410/1420 WirelessHART®
Gateway 23



Product removed from sale October 2003

Introduction

Product Overview

The FIELDVUE DVC5000 digital valve controller is designed to control the pneumatic actuator of a process control valve. It receives a current signal from a host and uses instrument air supply to create a metered pressure output signal to the pneumatic actuator. Movement of the actuator as it positions the process control valve is measured by the DVC5000 travel sensor as its primary feedback. The name plate is located on the side of the DVC5000 master module assembly and indicates the model name, individual product serial number, and any applicable third party approvals.

Purpose of this document

This specification is designed to be a technical reference for HART capable host application developers, system integrators and knowledgeable end-users. It also provides functional specifications (e.g., commands, enumerations and performance requirements) used during field device development, maintenance and testing. This document assumes the reader is familiar with HART Protocol requirements and terminology. Additional product information is available in the DVC5000 product literature, available from your [Emerson sales office](#) or Local Business Partner.

Abbreviations and definitions

AR	Alert Record
Configuration Variables	Variables which represent nonvolatile values of manufacturing-initialized data or user-specified configuration information. These variables cannot be enumerated via Command 54 and as such stand on their own with no associated units or range information.
Device Variable	Measured variables that are exposed to HART and can be enumerated using Command 54. Generally there are variables whose ID is in the range of 0 to 10 and are associated with units codes, status, and range values.
Enumeration	A pre-defined set of values or text.
MV	Measured Variable, a physical input to the instrument.
NV	Named Variable – a logical point inside the device, hard-mapped to a given MV as the source of NV data.
Point	A term that applies to diagnostic data packets. It is defined as a collection of periodically sampled variables captured at a single instant in time. It does not include the “Monitor” point.
Byte	An 8-bit unsigned integer.
Word	A 16-bit unsigned integer.
Float	Refers to the IEEE 754 floating point format.
Packed ASCII	A special form of characters defined by HART in which 6-bit ASCII characters are packed into byte data.
Standard Span Format	A proprietary 16-bit integer format for numerical values used by some of this device’s Device Specific commands.

Reference Documentation

HART Smart Communications Protocol Specification Revision 5; a group of documents specifying the HART Communication Protocol, physical layers, and Data Link Layers as defined by the HART Communications Foundation.

The DVC5000 is not an Active product. Contact your [Emerson sales office](#) or Local Business Partner if a copy of the instruction manual is required.

Device Identification

Manufacturer Name	Fisher Controls	Model Name(s)	DVC5000	
Manufacture ID Code	19	(13 Hex)	Device Type Code	02
				(02 Hex)
HART Protocol Revision	5		Device Revision	2 or 3
User Selectable HART Revision between HART 5 and HART 7	No			
Number of Device Variables	9			
Physical Layers Supported	FSK			
Physical Device Category	Valve Positioner			

Product Interfaces

Control Valve Interface

The DVC5000 digital valve controller is mechanically attached to the valve's actuator by means of a mounting bracket. The control valve's position is conveyed to the travel sensor of the DVC5000 digital valve controller by means of the feedback bracket attached to the actuator's stem and the rotating travel sensor.

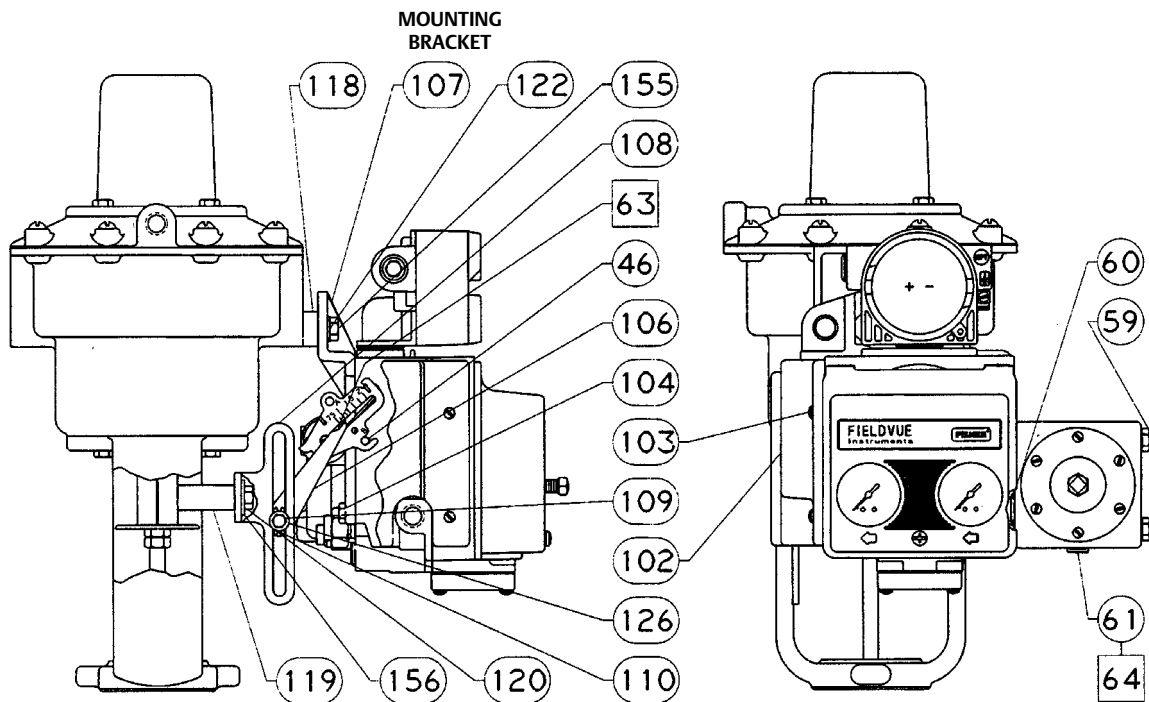

Pneumatic tubing connected to the DVC5000 brings instrument supply air to the DVC5000 and takes controlled output air from the DVC5000 to the actuator. The pressure sensor in the DVC5000 measures the output pressure and presents it as a device variable.

Host interface

The input to the DVC5000 can either be two-wire 4-to-20 mA current loop (in point-to-point mode) or 24 VDC (in multi-drop mode). This input is connected in the DVC5000's terminal box on two terminals marked "LOOP +" and "LOOP -". Refer to the DVC5000 instruction manual for connection details.

Internal Jumpers And Switches

The input to the DVC5000 is determined by the Pt-Pt/Multi-Drop switch on the printed wiring board.

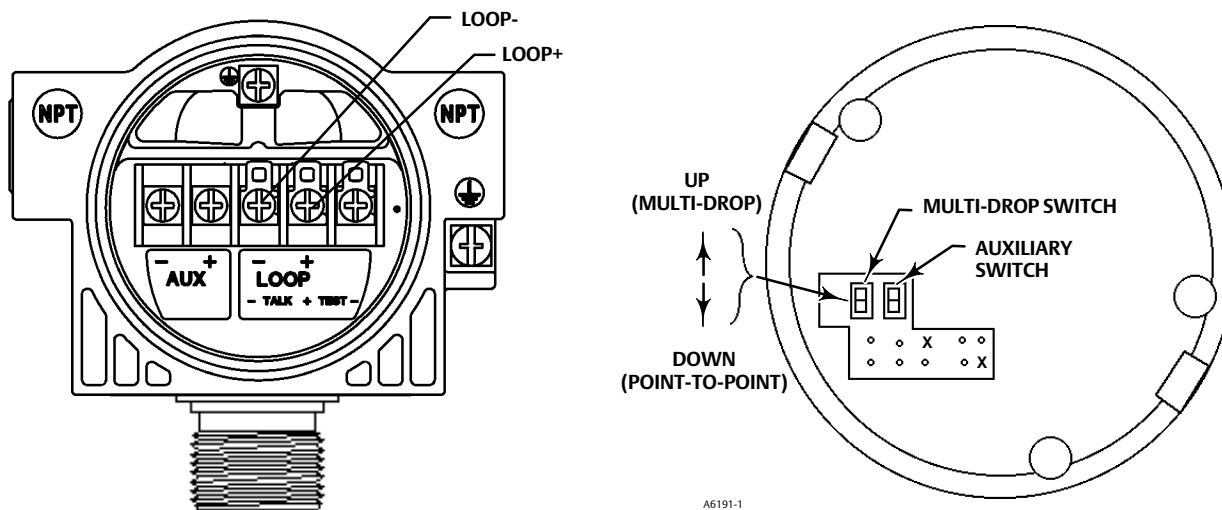

Refer to the DVC5000 instruction manual for additional details on the settings of the selection switches.

Write Protection

There are two Write Protection states for the DVC5000: Not Protected or Protected. Protected prevents configuration and calibration changes to the instrument. The default setting is Not Protected. Protection is controlled under software control. Write Protection can be enabled remotely. However, to disable Write Protection to Not Protected, you must have physical access to the instrument. The procedure will require you to short the AUX terminals inside the terminal box when directed by the software as a security measure.

Firmware Upgrade

The firmware of a DVC5000 printed wiring board assembly cannot be upgraded.

Dynamic Variables

Four Dynamic Variables are implemented.

	COMMAND/RESPONSE MODE		BURST MODE	
	Default Meaning	Units	Default Meaning	Units
PV	Analog Input	mA, %	Valve Travel	%
SV	Aux Contact Status	%	Travel Setpoint	%
TV	Pressure	PSI, BAR, KPA	Pressure	PSI, BAR, KPA
FV	Valve Travel	%	FW5: Aux Status	%
			FW6: Drive Signal	%

Device Variables

These variables represent measurements taken by the device, are read only values, and are all in float format. These can be read with Commands 33 and 54.

Variable ID	Meaning	Units
0	Analog Input	mA, %
1	Auxiliary Contact Status (0% = Open, 100% = Shorted)	%
2	Output Pressure	PSI, BAR, KPA
3	Valve Travel	%
4	Drive Signal	%
5	Unused	
6	Travel Setpoint	%
7	Unused	
8	Unused	
9	Implied Valve Position (Travel Target)	%
10	Valve Travel	%
211	Temperature	°C, °F

Unit Codes

Variable Units Code	Units
0	No Units
6	Pounds per square inch, psi
7	Bar
12 (\$0C)	Kilopascals, kPa
32 (\$20)	Celsius, °C
33 (\$21)	Fahrenheit, °F
39 (\$27)	Milliamps, mA
57 (\$39)	Percent, %

Status Information

Device Status

The Field Device Status Byte is the only status byte defined in the HART protocol. The order and meaning of each of the eight bits within the byte are fixed by the protocol. This byte is one of the status bytes included with each HART response. It is not part of the Command 48 data.

Bit	Device Revision	Name of Status Bit	Meaning
7	2, 3	Field Device Malfunction	Set / cleared by the firmware based on self test results. This bit is set if the pressure, position or temperature sensors provide invalid readings.
6	2, 3	Configuration Changed	Two such bits exist internally, one for each HART master. Both copies are set when any variable, HART message, tag, descriptor or date are changed from HART. Cleared by command 38, separately for each master. This bit survives loss of power.
5	2, 3	Cold Start	Set by the firmware whenever a RESET sequence is executed or at initial device power up. Cleared by the first HART command.
4	2, 3	More Status	Active when any bit in command 48 is active.
3	2	Not Used	
	3	Analog Input Fixed	Active if the Instrument Mode of the DVC5000 is in the "Out Of Service" condition or if the Control Mode of the DVC5000 is in one of the digital set point modes.
2	2	Analog Input Saturated	Active if the Instrument Mode of the DVC5000 is in the "Out Of Service" condition or if the Control Mode of the DVC5000 is in one of the digital set point modes.
	3	Not Used	
1	2, 3	Internal Sensor Out of Limits	(This bit is named "Non-Primary Variable Out Of Limits" in the HART documentation for transmitters. It has been renamed to reflect the fact that these variables are INTERNAL INPUTS to FIELDVUE products). The firmware sets this bit when any sensor (pressure, position, temperature) exceeds its operating limits.
0	2, 3	Loop Current Out of Range	Set when any variable 0 (Analog Input) is saturated.

Universal Commands

The DVC5000 field device implements all HART Revision 5 Universal Commands.

Command 0: Read Unique Identifier

Command 1: Read Primary Variable

Command 2: Read Loop Current and Percent of Range

Command 3: Read Dynamic Variables and P.V. Current

Command 6: Write Polling Address

Command 11: Read Unique Identifier Associated with Tag

Command 12: Read Message

Command 13: Read Tag, Descriptor, Date

Command 14: Read Primary Variable Transducer Information

Command 15: Read Primary Variable Output Information

Command 16: Read Final Assembly Number

Command 17: Write Message

Command 18: Write Tag, Descriptor, Date

Command 19: Write Final Assembly Number

Command 0: Read Unique Identifiers

	Byte	Description	Format	Value
Request Data Bytes	none			
Response Data Bytes	0	Data type expansion code	Byte, hex	\$FE
	1	Manufacturer identification code	Byte, hex	\$13
	2	Manufacturer's Device Type code	Byte, hex	\$02
	3	Number of preambles	Byte, hex	\$05
	4	Universal command revision	Byte, hex	\$05
	5	Device revision	Byte, hex	See table 1 below
	6	Software revision	Byte, unsigned integer	See table 1 below
	7	Hardware revision	Byte, unsigned integer	See table 2 below
	8	Device function flags	Not Used	\$00
	9	Device Identification number	3 Bytes, hex	
	Code	Description		
Command-Specific Response Codes	none			

Table 1. Device and Software Revision

Device Revision	Software Revision	Description
\$02	\$03	Firmware Revision 3
	\$04	Firmware Revision 4
\$03	\$05	Firmware Revision 5
	\$06	Firmware Revision 6

Table 2. Hardware Revision

Hardware Revision	Description
(\$08)	Not applicable
(\$10)	Hardware revision 2
(\$18)	Hardware revision 3
(\$20)	Hardware revision 4
(\$28)	Hardware revision 5

Command 1: Read Primary Variable

This command reads the value of the DVC5000’s measured Valve Travel. The units are “%”.

	Byte	Format	Description
Request Data Bytes	none		
Response Data Bytes	0	Byte, hex	Valve Travel Unit Code, 57(%)
	1-4	Float	Valve Travel value
	Code	Class	Description
Command-Specific Response Codes	none		

Command 2: Read Loop Current and Percent of Range

This command reads the value of the DVC5000’s loop current in implied units of “mA” (regardless of the configured units setting) and the measured Valve Travel in units of “%”.

	Byte	Format	Description
Request Data Bytes	none		
Response Data Bytes	0-3	Float	Loop Current
	4-7	Float	Valve Travel
	Code	Class	Description
Command-Specific Response Codes	none		

Command 3: Read Dynamic Variables and Loop Current

This command is used to read the value of Loop Current and the four Dynamic Variables.

The default Dynamic Variable assignment and the Variable Units Codes are shown on page 6.

	Byte	Format	Description
Request Data Bytes	none		
Response Data Bytes	0-3	Float	Loop Current (implied units of “mA”)
	4	Byte, hex	Primary Variable (PV) units code
	5-8	Float	Primary Variable (PV) value
	9	Byte, hex	Secondary Variable (SV) units code
	10-13	Float	Secondary Variable (SV) value
	14	Byte, hex	Tertiary Variable (TV) units code
	15-18	Float	Tertiary Variable (TV) value
	19	Byte, hex	Fourth Variable (FV or QV) units code
	20-23	Float	Fourth Variable (FV or QV) value
	Code	Class	Description
Command-Specific Response Codes	8		Warning – Value read invalid (one of the variables is out of range)

Command 14: Read Primary Variable Transducer Information

Note

The Transducer Serial Number is not applicable to the DVC5000 and is set to “0”.

	Byte	Format	Description	Returned Value	
				Device Revision 2	Device Revision 3
Request Data bytes	None				
Response Data Bytes	0-2	UINT24	Transducer Serial Number	000000	000000
	3	Enum	Transducer Limits and Minimum Span Units Code	39 (mA)	250 (Not Used)
	4-7	Float	Upper Transducer Limit	41C00000	7FA00000 (Not A Number NAN)
	8-11	Float	Lower Transducer Limit	00000000	7FA00000 (Not A Number NAN)
	12-15	Float	Minimum Span	40800000	7FA00000 (Not A Number NAN)
	Code	Class	Description		
Response Codes	None				

Command 15: Read Primary Variable Output Information

This command returns the upper/lower range values for the measured Valve Travel.

The range values can be changed via Command 35.

	Byte	Format	Description	Returned Value
Request Data bytes	None			
Response Data Bytes	0	Enum	PV Alarm Selection Code (see Common Table 6, Alarm Selection Codes). The Alarm Selection Code indicates the action taken by the device under error conditions. For Actuators, the action taken by the positioner is indicated.	250 (Not Used)
	1	Enum	PV Transfer Function Code (see Common Table 3, Transfer Function Codes). The Transfer Function Code must return "0", Linear, if transfer functions are not supported by the device.	250 (Not Used)
	2	Enum	AI Upper and Lower Range Values Units Code	57 (%)
	3-6	Float	AI Upper Range Value	42C80000
	7-10	Float	AI Lower Range Value	00000000
	11-14	Float	PV Damping Value	250 (Not Used)
	15	Enum	Write Protect Code	0 or 1
	16	Enum	Reserved	
	Code	Class	Description	
Response Codes	None			

Common-Practice Commands

The DVC5000 field device supports the following common practice commands:

Supported Commands

- Command 33: Read Device Variables
- Command 35: Write Primary Variable Range Values
- Command 38: Reset Configuration Change Flag
- Command 42: Master Reset
- Command 48: Read Additional Status
- Command 50: Read Dynamic Variable Assignments *
- Command 54: Read Device Variable Information
- Command 108: Write Burst Mode Command Number*
- Command 109: Burst Control Mode*

*Command 50, 108, and 109 are supported in Device Revision 3 only

Command 33: Read Device Variables

This command is used to read the value of up to four selected Device Variables.

The Device Variables and the Variable Units Code are listed on page 6.

Note: If any one of the requested variable IDs is invalid, the INVALID_SELECTION error will be returned along with no data bytes.

	Byte	Format	Description	Allowable choices
Request Data Bytes	0	Variable ID	Variable assigned to slot #0	See Device Variables on page 6
	1	Variable ID	Variable assigned to slot #1	See Device Variables on page 6
	2	Variable ID	Variable assigned to slot #2	See Device Variables on page 6
	3	Variable ID	Variable assigned to slot #3	See Device Variables on page 6
Response Data Bytes	0	Variable ID	Variable assigned to slot #0	
	1	Byte, hex	Slot #0 Variable units code	
	2-5	Float	Slot #0 Variable value	
	6	Variable ID	Variable assigned to slot #1	
	7	Byte, hex	Slot #1 Variable units code	
	8-11	Float	Slot #1 Variable value	
	12	Variable ID	Variable assigned to slot #2	
	13	Byte, hex	Slot #2 Variable units code	
	14-17	Float	Slot #2 Variable value	
	18	Variable ID	Variable assigned to slot #3	
	19	Byte, hex	Slot #3 Variable units code	
	20-23	Float	Slot #3 Variable value	
	Code	Class	Description	
Command-Specific Response Codes	2		Invalid selection – Invalid Variable ID (see note above)	

Command 35: Write Primary Variable Range Values

In the DVC5000, the Primary Variable is defined to be the measured Valve Travel.

This command is used to write the ranging values reported in Command 15. It sets the engineering units to be reported with 0% and 100% of calibrated travel.

This command will only be accepted when the DVC5000's Instrument Mode is in the "Out of Service" condition and will be rejected if Write Protection is in effect.

	Byte	Format	Description	Allowable choices
Request Data Bytes	0	UINT8	Upper and Lower Range Values Unit Code	57(%)
	1 - 4	Float	Primary Variable Upper Range Value	
	5 - 8	Float	Primary Variable Lower Range Value	
Response Data Bytes	0	UINT8	Upper and Lower Range Values Unit Code	57(%)
	1 - 4	Float	Primary Variable Upper Range Value	
	5 - 8	Float	Primary Variable Lower Range Value	
	Code	Class	Description	
Command-Specific Response Codes	2		Invalid selection - Units code did not match configured units	
	7		In Write Protect Mode	
	16		Access Restricted - Instrument Mode is not in "Out of Service" condition	
	32		Busy	

Command 38: Reset Configuration Change Flag

Resets the configuration changed flag in the DVC5000.

This command is only accepted from the primary HART Master. Any write to the DVC5000 other than digital setpoint values and write protect status will cause the configuration change flag to be set.

	Byte	Format	Description
Request Data Bytes	none		
Response Data Bytes	none		
	Code	Class	Description
Command-Specific Response Codes	16		Access Restricted (If command is issued from a Secondary master)

Command 42: Perform Master Reset

Responds immediately by performing a “warm” reset. This is not equivalent to power up in that restart modes and default IVP are not adopted and the real-time clock is not reset. All other data is read from nonvolatile memory and put into effect.

A “soft reset” command will be honored while the DVC5000 Instrument Mode is in the “Out-of-Service” condition.

	Byte	Format	Description
Request Data bytes	None		
Response Data Bytes	None		
	Code	Class	Description
Command-specific Response Codes	16	Error	Access Restricted (instrument mode \neq Out of Service)

Command 48: Read Additional Status

	Byte	Format	Description
Request Data bytes	0		None
Response Data Bytes	0	UInt8	Command 48 Response Byte 0
	1	UInt8	Command 48 Response Byte 1
	2	UInt8	Command 48 Response Byte 2
	3	UInt8	Command 48 Response Byte 3
	4	UInt8	Command 48 Response Byte 4
	5	UInt8	Command 48 Response Byte 5
	6	UInt8	Operating Mode
	7	UInt8	Reserved

Additional Device Status— DVC5000 Device Revision 2, Firmware 3, 4

Command 48 returns 5 bytes of data, with the following status information:

Byte	Bit	Name of Status Bit	Meaning
0	7	Reserved	
	6	No Free Time	1,2 Active if the microprocessor detects a fault in the servo execution period.
	5	RAM Failure	1,2 Active if there is a failure associated with the RAM memory.
	4	Program Failure	1,2 Active there is a failure associated with the ROM (program) memory.
	3	Critical NVM Failure	1,2 Active if there is a failure of non-volatile memory used for configuration data critical for instrument operation.
	2	Temperature Sensor Failure	1,2 Active when the instrument temperature sensor fails or the sensor reading is outside of the range of -60° to 100°C (-76° to 212°F).
	1	Pressure Sensor Failure	1,2 Active if any of the 3 pressure sensor readings are outside the range of -24.0% to 125.0% of the calibrated pressure for more than 60 seconds.
	0	Travel Sensor Failure	1,2 Active if the sensed travel is outside the range of -25.0% to 125.0% of calibrated travel.
1	7	Auto Cal in Progress Alert	2 Active when auto calibration is in progress.
	6	Dynamic Bypass Enabled	Active if Dynamic Bypass is enabled.
	5	Calibration In Progress Alert	2 Active when calibration is in progress.
	4	Diagnostics in Progress Alert	2 Active when a diagnostic test is in progress.
	3	Reserved	
	2	Custom Characterization	Custom Characterization in Effect active if the user-defined Custom Characterization is enabled.
	1	Input Characterization	Input Characterization in Effect active if any of the user-defined Characterizations other than "Linear" is enabled.
	0	Reserved	
2	7	Reserved	
	6	Non-Critical NVM Alert	2 Active if there is a failure of non-volatile memory used for data not critical for instrument operation.
	5	Cycle Counter High Alert	2 Active if the Cycle Counter exceeds the Cycle Count Alert Point.
	4	Travel Accumulator High Alert	2 Active if the Travel Accumulator exceeds the Travel Accumulator Alert Point.
	3	Reserved	
	2	Reserved	
	1	Offline / Failed Alert	2 Active if a shutdown alert has put the DVC5000 in a failed state.
	0	Auxiliary Input Alert	2 Active when the AUX input is configured as an alarm switch and the alarm is active

"Reserved" bits are always set to 0.

1. Sets "Field Device Malfunction".

2. Sets "More Status Available".

(continued)

Additional Device Status— DVC5000 Device Revision 2, Firmware 3, 4 (continued)

Byte	Bit	Name of Status Bit	Meaning
3	7	Reserved	
	6	Reserved	
	5	Reserved	
	4	Reserved	
	3	Reserved	
	2	Reserved	
	1	Reserved	
	0	Reserved	
4	7	Travel Alert Lo ²	Active when the Travel is below the Travel Alert Lo Point.
	6	Travel Alert Lo Lo ²	Active when the Travel is below the Travel Alert Lo Lo Point.
	5	Travel Alert Hi ²	Active when the Travel exceeds the Travel Alert Hi Point.
	4	Travel Alert Hi Hi ²	Active when the Travel exceeds the Travel Alert Hi Hi Point.
	3	Travel Deviation Alert ²	Active if the difference between the Travel Target and the Travel exceeds the Travel Deviation Alert Point for more than the Travel Deviation Time.
	2	Travel Limit/Cutoff Hi Alert ²	Active when the Travel exceeds the Hi Limit/Cutoff Point.
	1	Travel Limit/Cutoff Lo Alert ²	Active when the Travel falls below the Lo Limit/Cutoff Point.
0	Drive Signal Alert ²	Active when the Drive Signal exceeds target limits (<10% or >90%) for more than 20 seconds when not in Cutoff condition.	

"Reserved" bits are always set to 0.

1. Sets "Field Device Malfunction".

2. Sets "More Status Available".

Additional Device Status - DVC5000 Device Revision 3, Firmware 5, 6

Command 48 returns 7 bytes of data, with the following status information:

Byte	Bit	Name of Status Bit	Meaning
0	7	Reserved	
	6	No Free Time	1,2 Active if the microprocessor detects a fault in the servo execution period.
	5	RAM Failure	1,2 Active if there is a failure associated with the internal RAM memory.
	4	Drive Current Failure	1,2 Active when the drive current to the I/P converter is not flowing as expected.
	3	Critical NVM Failure	1,2 Active if there is a failure of non-volatile memory used for configuration data critical for instrument operation.
	2	Temperature Sensor Failure	1,2 Active when the instrument temperature sensor fails or the sensor reading is outside of the range of -60° to 100°C (-76° to 212°F).
	1	Pressure Sensor Failure	2 Active if any of the 3 pressure sensor readings are outside the range of -24.0% to 125.0% of the calibrated pressure for more than 60 seconds.
	0	Travel Sensor Failure	1,2 Active if the sensed travel is outside the range of -25.0% to 125.0% of calibrated travel.
1	7	Auto Cal in Progress Alert	2 Active when auto calibration is in progress.
	6	Dynamic Bypass Enabled	2 Active if Dynamic Bypass is enabled.
	5	Calibration In Progress Alert	2 Active when calibration is in progress.
	4	Diagnostics in Progress Alert	2 Active when a diagnostic test is in progress.
	3	High Performance in Effect	Active when the instrument is using the High Performance Tuning Parameters.
	2	Custom Characterization	Custom Characterization in Effect active if the user-defined Custom Characterization is enabled.
	1	Input Characterization	Input Characterization in Effect active if any of the user-defined Characterizations other than "Linear" is enabled.
	0	PWB Set to "Multi-Drop"	2 Active is PWB switch is set to "Multi"
2	7	Reserved	
	6	Non-Critical NVM Alert	2 Active if there is a failure of non-volatile memory used for data not critical for instrument operation.
	5	Cycle Counter High Alert	2 Active if the Cycle Counter exceeds the Cycle Count Alert Point.
	4	Travel Accumulator High Alert	2 Active if the Travel Accumulator exceeds the Travel Accumulator Alert Point.
	3	Instrument Time is Invalid Alert	2 Active if the instrument has been powered down since the last time the instrument clock was set.
	2	Reserved	
	1	Offline / Failed Alert	2 Active if a shutdown alert has put the DVC5000 in a failed state.
	0	Auxiliary Input Alert	2 Active when the AUX input is configured as an alarm switch and the alarm is active

"Reserved" bits are always set to 0.

1. Sets "Field Device Malfunction".

2. Sets "More Status Available".

(continued)

Additional Device Status - DVC5000 Device Revision 3, Firmware 5, 6 (continued)

Byte	Bit	Name of Status Bit	Meaning
3	7	Reserved	
	6	Reserved	
	5	Reserved	
	4	Reserved	
	3	Reserved	
	2	Reserved	
	1	Reserved	
	0	Reserved	
4	7	Travel Alert Lo 2	Active when the Travel is below the Travel Alert Lo Point.
	6	Travel Alert Lo Lo 2	Active when the Travel is below the Travel Alert Lo Lo Point.
	5	Travel Alert Hi 2	Active when the Travel exceeds the Travel Alert Hi Point.
	4	Travel Alert Hi Hi 2	Active when the Travel exceeds the Travel Alert Hi Hi Point.
	3	Travel Deviation Alert 2	Active if the difference between the Travel Target and the Travel exceeds the Travel Deviation Alert Point for more than the Travel Deviation Time.
	2	Travel Limit/Cutoff Hi Alert 2	Active when the Travel exceeds the Hi Limit/Cutoff Point.
	1	Travel Limit/Cutoff Lo Alert 2	Active when the Travel falls below the Lo Limit/Cutoff Point.
	0	Drive Signal Alert 2	Active when the Drive Signal exceeds target limits (<10% or >90%) for more than 20 seconds when not in Cutoff condition.
5	7	Reserved	
	6	Reserved	
	5	Reserved	
	4	Reserved	
	3	Reserved	
	2	Reserved	
	1	Reserved	
	0	Reserved	
Byte	Left Digit	Name of Status Bit	
6	"0"	Out of Service	
	"1"	In Service	
	Right Digit	Name of Status Bit	
	"3"	"Analog (RSP)" Control Mode	
	"2"	"Digital" Control Mode	
	"1"	Not used	
	"0"	"Test" Control Mode	

"Reserved" bits are always set to 0.

1. Sets "Field Device Malfunction".
2. Sets "More Status Available".

Command 50: Read Dynamic Variable Assignments

This command returns a list of four device variable codes taken from table DVC Device Variables which are returned in Command 3.

	Byte	Format	Description
Request Data Bytes	None		
Response Data Bytes	0	UINT8	ID of variable returned as the first variable (PV) in Command #3
	1	UINT8	ID of variable returned as the second variable (SV) in Command #3
	2	UINT8	ID of variable returned as the third variable (TV) in Command #3
	3	UINT8	ID of variable returned as the fourth variable (FV) in Command #3
	Code	Class	Description
Command-Specific Response Codes	None		

Command 54: Read Device Variable Information

Used to identify each of the Device Variables in the range of IDs 0, 1, 2, 3, 4, 6, 9, 10, and 211. Responds with the Sensor Serial Number, Sensor range Units, Sensor ranges, Damping Value, and Minimum Span of the selected Variable. The Variable range values will be in the same units as the Variable Units.

	Byte	Format	Description
Request Data Bytes	0	Enum	Device Variable ID, this command is applicable to variables 0, 1, 2, 3, 4, 6, 9, 10, and 211. All others will return invalid selection
Response Data Bytes	0	UINT8	Device Variable ID (see "Device Variables" table page 6)
	1-3		Device Variable Sensor Serial Number, 24-bit number (NOT USED - always zero)
	4	UINT8	Device variable units code (see "Units Codes" table on page 6.)
	5-8	Float	Device Variable Upper Range
	9-12	Float	Device Variable Lower Range
	13-16	Float	Device Variable Damping Value, (NOT USED - always zero)
	17-20	Float	Device Variable Minimum Span (NOT USED - always zero)
	Code	Class	Description
Command-Specific Response Codes	2		Invalid Selection

Device-Specific Commands

The DVC5000 field device supports device-specific commands. However, these device-specific commands require use of the ValveLink software application or DD methods and cannot be utilized outside of those controlled environments.

Burst Mode

Device Revision 3 of this field device supports Burst Mode.
Device Revision 2 of this field device does not support Burst Mode.

Catch Device Variable

This field device does not support Catch Device Variable.

Performance

Refer to the instruction manual, available from your [Emerson sales office](#) or Local Business Partner.

Annex A Compatibility Checklist

Manufacturer, Model, and Revision	Fisher Controls DVC5000 Device Revision 2 and 3	
Device Type	Pneumatic Control Valve Positioner	
HART Protocol Revision	5	
User switchable between HART 5 mode and HART 7 mode?	No	
Device Description Available?	Yes	
Number and type of process connections	None	
Number of host connections	Input: Control signal to Loop \pm terminals	
Number of Dynamic Variables	4	
Mappable Dynamic Variables?	No	
Number of Device Variables	9	
Number of Supported Common Practice Commands	Device Revision 2	6
	Device Revision 3	9
Burst Mode?	Device Revision 2	No
	Device Revision 3	Yes
Capture Device Variables?	No	
Write Protection?	Proprietary method	

Annex B DVC5000 Parameters as part of a Rosemount 1410 / 1420 WirelessHART Gateway

A FIELDVUE DVC5000 can join a wireless network through the addition of a Rosemount 775 THUM *WirelessHART* adapter. The wireless adapter acts both as a HART modem for communications coming to the DVC5000 from application software and as an independent master issuing commands periodically to the wired device pertaining to the device's status. This independently gathered status information is relayed back to the Rosemount 1410 or 1420 Wireless Gateway and is made available to the user either through viewing the HTML interface or via mapping as "Published Data" parameters via the Gateway's MODBUS or OPC outputs.

For HART 5 devices the PV, SV, TV, and QV variables can be mapped.

Configure the THUM as follows:

Navigate to Configure > Manual Setup
Under the *Wired Device* tab select *Configure HART Polling*

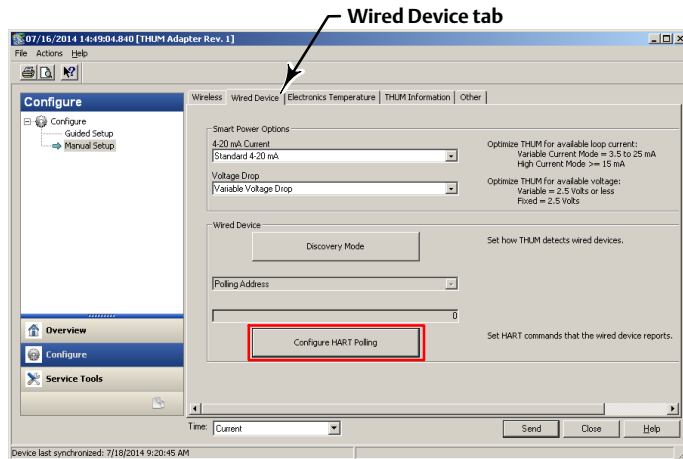

FOR PRIMARY DEVICE INFORMATION:
Select PV, SV, TV, and QV

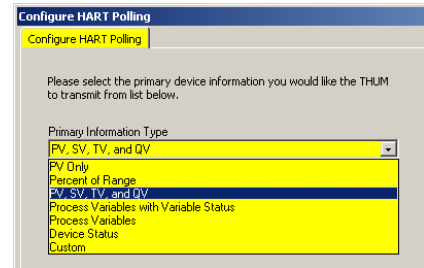

Select Yes if changes are required

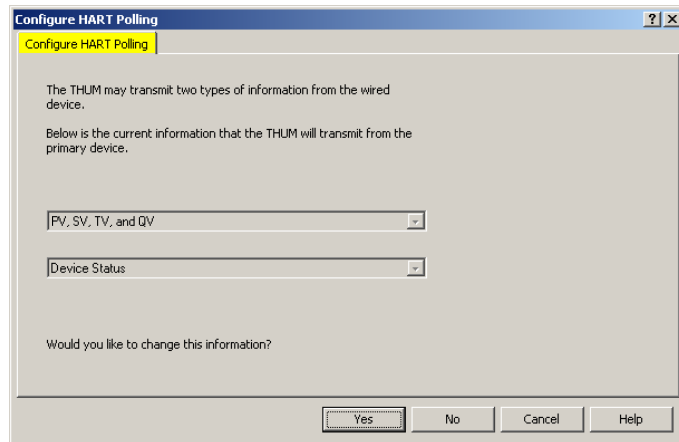

FOR SECONDARY DEVICE INFORMATION:
Select Device Status

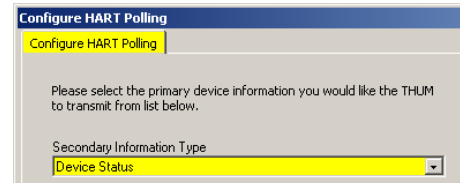

The FIELDVUE instrument is defined on the Gateway by “Tag” (read from the device’s “Message” field).

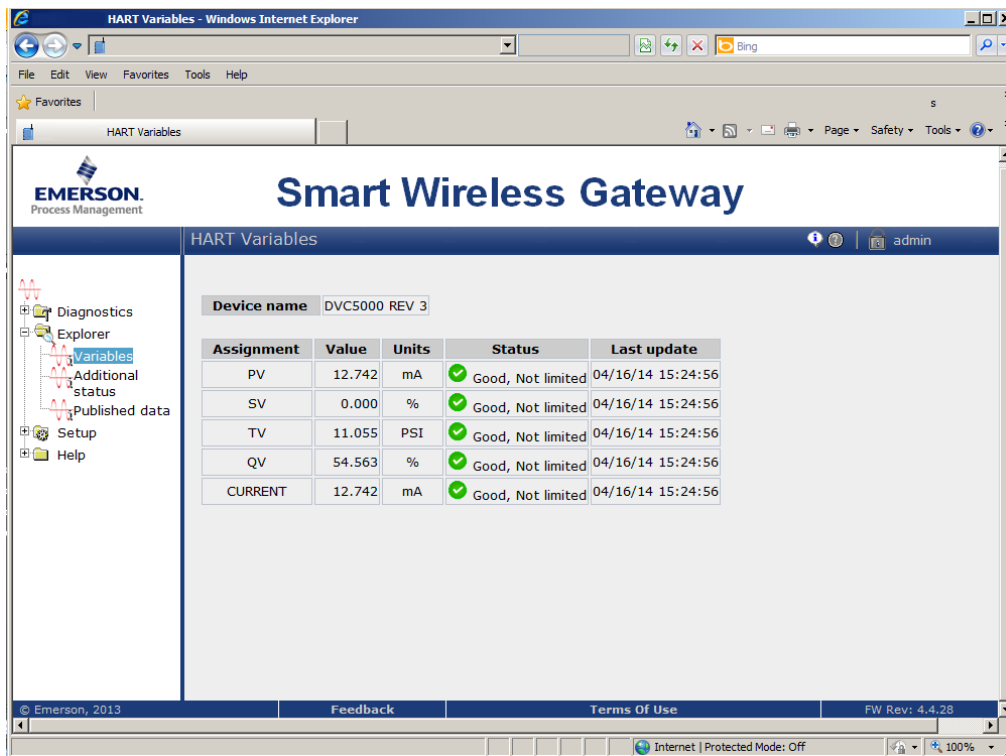

For each Tag, the Gateway provides updated values for:

- Variables
- Additional Status
- Published Data

Published Data, used for the Gateway’s OPC and Modbus outputs, falls into the following categories:

Field Device Identification Values:

Values that define the identity of the DVC5000. These include:

- MANUFACTURER (for “Fisher Controls” the value is “19”)
- DEVICE_TYPE (for a DVC5000 the value is “2”)
- DEVICE_REVISION
- HARDWARE_REVISION
- SOFTWARE_REVISION
- DEVICE_ID
- UNIVERSAL_REVISION (HART version)
- REQUEST_PREAMBLES
- RESPONSE_PREAMBLES

Variable information:

The Gateway receives updates concerning the DVC5000’s four “Dynamic Variables”. The information for any given device variable is displayed by:

1. Dynamic Variable indicator (“PV”, “SV”, etc.)
2. The Device Variable ID number assigned to that Dynamic Variable

	Dynamic Variable	Device Variable ID	Device Variable Name(s)
Analog Input	PV	0	ANALOG_INPUT
Aux Contact Status	SV	1	
Pressure	TV	2	OUTPUT_PRESSURE
Travel	QV	3	TRAVEL
Milliamp Current		245	CURRENT

Either of these choices (Dynamic Variable or Device Variable ID) can be substituted for the “#” sign in the Variable Identifier fields below.

Variable Identifier	Comments / Explanation
#	See any of the variable identifiers in the table immediately above.
#_CLASS	Always “0”.
#_CODE	The “Device Variable ID” number in the table immediately above.
#_HEALTHY	A “true” or “false” indication of the health of the sensor providing this value.
#_STATUS	
#_UNITS	Decimal “Variable Units code” number from the “Units Codes” table on page 6.

Device Status:

The eight standard status conditions (present in ANY HART field device) are all represented by a Boolean “true” or “false” state. These eight conditions, discussed on page 7, are:

- DEVICE_MALFUNCTION
- CONFIGURATION_CHANGED
- COLD_START
- MORE_STATUS_AVAILABLE
- LOOP_CURRENT_FIXED
- LOOP_CURRENT_SATURATED
- NONPRIMARY_VALUE_OUT_OF_LIMITS
- PRIMARY_VALUE_OUT_OF_LIMITS

Detailed Device Alerts:

The Alert Groupings are:

- ADDITIONAL_STATUS_0
- ADDITIONAL_STATUS_1
- ADDITIONAL_STATUS_2
- ADDITIONAL_STATUS_3
- ADDITIONAL_STATUS_4
- ADDITIONAL_STATUS_5*
- ADDITIONAL_STATUS_6*

* ADDITIONAL_STATUS_5 and ADDITIONAL_STATUS_6 are supported in Device Revision 3 only

Each of these status bytes represent eight individual bits with values that range from “00” to “255”. To determine which of the eight bits are active requires converting a decimal value to its binary equivalent value. Refer to Command 48 on page 16 for details on the individual alert bits inside of each Additional Status Byte.

Neither Emerson, Emerson Automation Solutions, nor any of their affiliated entities assumes responsibility for the selection, use or maintenance of any product. Responsibility for proper selection, use, and maintenance of any product remains solely with the purchaser and end user.

Fisher, FIELDVUE, and ValveLink are marks owned by one of the companies in the Emerson Automation Solutions business unit of Emerson Electric Co. Emerson Automation Solutions, Emerson, and the Emerson logo are trademarks and service marks of Emerson Electric Co. HART and *WirelessHART* are marks owned by the HART Communication Foundation. All other marks are the property of their respective owners.

The contents of this publication are presented for informational purposes only, and while every effort has been made to ensure their accuracy, they are not to be construed as warranties or guarantees, express or implied, regarding the products or services described herein or their use or applicability. All sales are governed by our terms and conditions, which are available upon request. We reserve the right to modify or improve the designs or specifications of such products at any time without notice.

Emerson Automation Solutions
Marshalltown, Iowa 50158 USA
Sorocaba, 18087 Brazil
Cernay, 68700 France
Dubai, United Arab Emirates
Singapore 128461 Singapore

www.Fisher.com

