

Dimensions Spur gearboxes

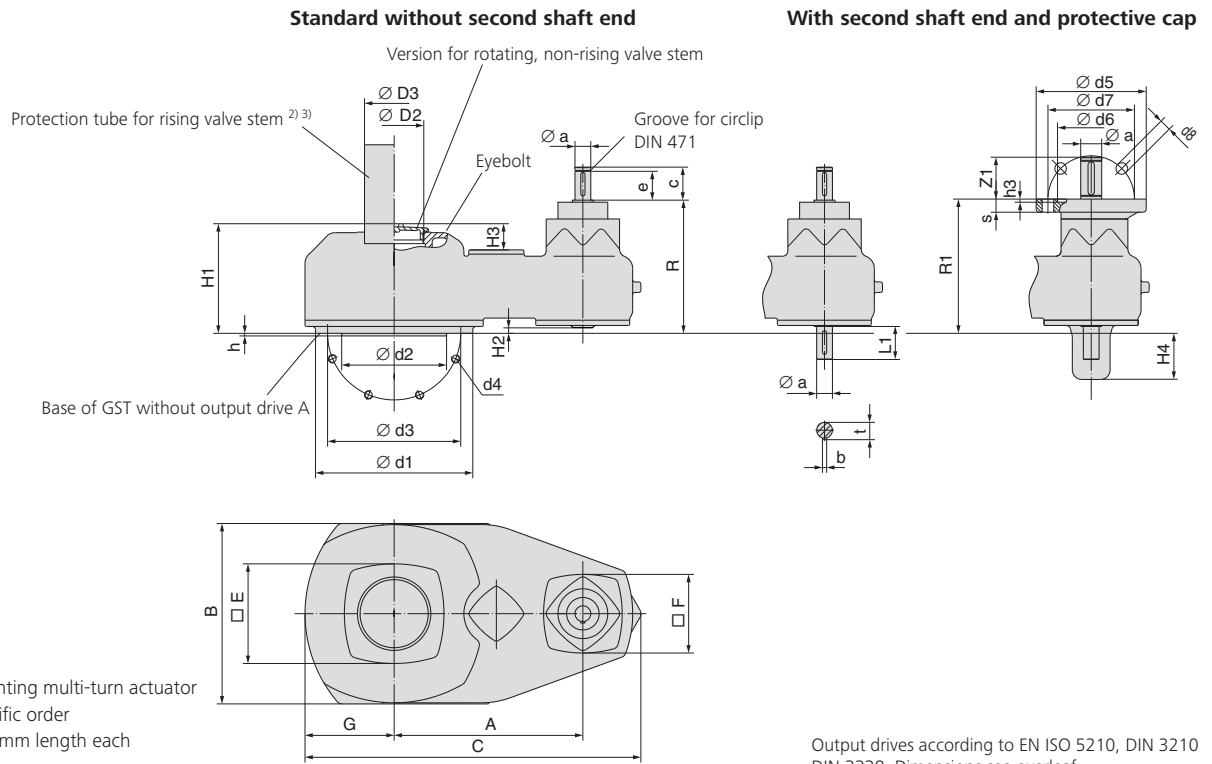

- 1) Flange for mounting multi-turn actuator
- 2) Only upon specific order
- 3) In steps of 100 mm length each
- 4) Without spigot

Output drives according to EN ISO 5210, DIN 3210 DIN 3338, Dimensions see overleaf

Dimensions	GST 10.1	GST 14.1	GST 14.5	GST 16.1	GST 25.1	GST 30.1	GST 35.1	GST 40.1
EN ISO 5210/DIN 3210	F10 (G0)	F14 (G1/2)	F14 (G1/2)	F16 (G3)	F25 (G4)	F30 (G5)	F35 (G6)	F40 (G7 ⁴⁾)
A	175	240	240	300	360	380	410	445
B	138	188	188	234	344	374	454	504
C	305	395	395	480	640	675	750	810
Ø D2	G 2 "	G 2 ½ "	G 2 ½ "	G 3 "	G 4 "	G 5 "	M190 x 3	M220 x 3
Ø D3	60 x 3.7	76 x 3.7	76 x 3.7	89 x 4.1	114 x 4.5	140 x 4.9	191 x 8	219 x 10
□ E	96	106	106	130	200	220	275	320
□ F	110	110	110	110	150	150	150	145
G	65	90	90	115	170	185	225	250
H1	118	148	148	183	208	243	329	348
H2	9	15	15	15	9	14	23	28
H3	28	45	45	58	61	69	81	84
H4	41	53	53	53	88	83	97	92
R	157	171	171	196	253/263	258/268	356/349	361/354
R1	160	171	171	195	256	261	349	354
Z1	40	40/60	40/60	60	60/80	60/80	80/100	80/100
Ø a	20	20/30	20/30	30	30/40	30/40	40/50	40/50
b	6	6/8	6/8	8	8/12	8/12	12/14	12/14
c	42	42/60	42/60	60	63/73	63/73	73/100	73/100
Ø d1	125	175	175	210	300	350	415	475
Ø d2 f8	70(60)	100	100	130	200 (160)	230 (180)	260 (220)	300 ⁴⁾
Ø d3	102	140	140	165	254	298 (300)	356	406
d4	4 x M10	4 x M16	4 x M16	4 x M20	8 x M16	8 x M20	8 x M30	8 x M36
e	38	38/55	38/55	55	55/65	55/65	65/-	65/-
h	3	4	4	5	5	5	5	5 ⁴⁾
L1	40	40/60	40/60	60	60/80	60/80	80/100	80/100
t	22.5	22,5/33	22,5/33	33	33/43	33/43	43/53,5	43/53,5
EN ISO 5210 ¹⁾	F10/F14	F10/F14	F10/F14	F14	F14/F16	F14/F16	F14/F16/F25	F16/F25
DIN 3210 ¹⁾	G0/G1/2	G0/G1/2	G0/G1/2	G1/2	G1/2/G3	G1/2/G3	G1/2/G3/G4	G3/G4

Flange for mounting multi-turn actuator

EN ISO 5210	F10	F14	F16	F25	F40
DIN 3210		G0	G1/2	G3	G4
Ø d5	125	125	175	210	300
Ø d6	70	60	100	130	160
Ø d7	102	102	140	165	254
Ø d8	11	11	18	22	18
h3	5	5	5	6	6
s	12	12	17	25	25

We reserve the right to alter data according to improvements made. Previous documents become invalid with the issue of this document.

Dimensions Valve attachments according to EN ISO 5210, DIN 3210

Stem nut

Dimensions	GST 10.1	GST 14.1/GST 14.5	GST 16.1	GST 25.1	GST 30.1	GST 35.1	GST 40.1
EN ISO 5210	F10	F14	F16	F25	F30	F35	F40
DIN 3210	G0	G1/2	G3	G4	G5	G6	G7
F max. kN	70	160	250	380	460	875	1375
Ø d1	125	175	210	300	350	415	475
Ø d2	70 60	100	130	200 160	230 180	260 220	300
Ø d3	102	140	165	254	298 300	356	406
d4	M10	M16	M20	M16	M20	M30	M36
Ø d5	42	60	80	100	120	160	180
Ø d6 max.	40	57	75	95	115	155	175
g	50	65	80	130	160	185	225
h	3	4	5	5	5	5	8
h3	15	25	35	20	25	38	45
L	47	60	75	126	156	175	219
Z	4	4	4	8	8	8	8
Weight kg	2.8	6.8	11.7	42	69	125	200

Type
EN ISO 5210
DIN 3210

GK 10.2 – GK 16.2 GK 25.2 – GK 40.2

Arrangement of holes d4

Output drive plug sleeve ³⁾

Dimensions	GST 10.1	GST 14.1/GST 14.5	GST 16.1	GST 25.1	GST 30.1	GST 35.1	GST 40.1
EN ISO 5210	F10	F14	F16	F25	F30	F35	F40
DIN 3210	G0	G1/2	G3	G4	G5	G6	G7
b JS 9 ¹⁾	12	18	22	28	32	40	45
d7 H9	42	60	80	100	120	160	180
Ø d7 min.	30	45	60	75	90	120	140
h3	15	25	30	28	30	50	60
L1	45	65	80	110	130	180	200
t ¹⁾	45.3	64.4	85.4	106.4	127.4	169.4	190.4

Type
EN ISO 5210 **B 1 = Ø d7**
EN ISO 5210 **B 2 < Ø d7 > Ø d7 min.**
DIN 3210 **B = Ø d7**

For missing dimensions, refer to type A

Bore with keyway

Dimensions	GST 10.1	GST 14.1/GST 14.5	GST 16.1	GST 25.1	GST 30.1	GST 35.1	GST 40.1
EN ISO 5210	F10	F14	F16	F25	F30	F35	F40
DIN 3210	G0	G1/2	G3	G4	G5	G6	G7
b JS 9 ¹⁾	6	8	12	14	18	22	28
Ø d10 H9	20	30	40	50	60	80	100
Ø dy max.	30	45	60	75	90	120	140
h3	15	25	30	28	30	50	60
L1	45	65	80	110	130	180	200
t ¹⁾	22.8	33.3	43.3	53.8	64.4	85.4	106.4
Weight kg	0.4	1.1	2.4	5.1	8.6	21.2	27.5

Type
EN ISO 5210 **B 3 = Ø d10**
EN ISO 5210 **B 4 ≤ Ø dy**
DIN 3210 **E = Ø d10**

For missing dimensions, refer to type A

Dog coupling ³⁾

Dimensions	GST 10.1	GST 14.1/GST 14.5	GST 16.1	GST 25.1	GST 30.1	GST 35.1	GST 40.1
EN ISO 5210	F10	F14	F16	F25	F30	F35	F40
DIN 3210	G0	G1/2	G3	G4	G5	G6	G7
b1 H11	14	20	24	30	40	45	50
Ø d11 H11	28	38	47	64	75	105	125
Ø d11 min.	20	30	40	50	60	80	100
Ø d11 max. ²⁾	42	60	80	100	120	160	180
Ø d12	55	80	100	130	160	200	230
h3	15	25	30	28	30	50	60
h11	7	8	10	11	13	17	20

Type
DIN 3338 **C = Ø d11**

For missing dimensions, refer to type A

Shaft end

Dimensions	GST 10.1	GST 14.1/GST 14.5	GST 16.1	GST 25.1	GST 30.1	GST 35.1	GST 40.1
EN ISO 5210	F10	F14	F16	F25	F30	F35	F40
DIN 3210	G0	G1/2	G3	G4	G5	G6	G7
Ø d8 g6	20	30	40	50	60	80	100
b3 h9	6	8	12	14	18	22	28
h3	15	25	30	28	30	50	60
L2	1.5	2	3	3	3	3	3
L3	45	63	80	100	110	110	140
L4	50	70	90	110	120	120	150
L5	55	76	97	117	126	125	162
t2	22.5	33	43	53.5	64	85	106
Weight kg	0.7	2	4.3	9	15	34	50

Type
DIN 3210 **D**

For missing dimensions, refer to type A

1) Dimensions depend on Ø d7/ Ø d10, refer to DIN 6885-1
 2) For rising valve stem Ø d11 max. = Ø d5 of type A
 3) Weight included in actuator

We reserve the right to alter data according to improvements made. Previous documents become invalid with the issue of this document.