

SUWF-15~50

Normally close types

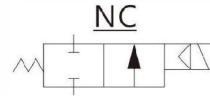
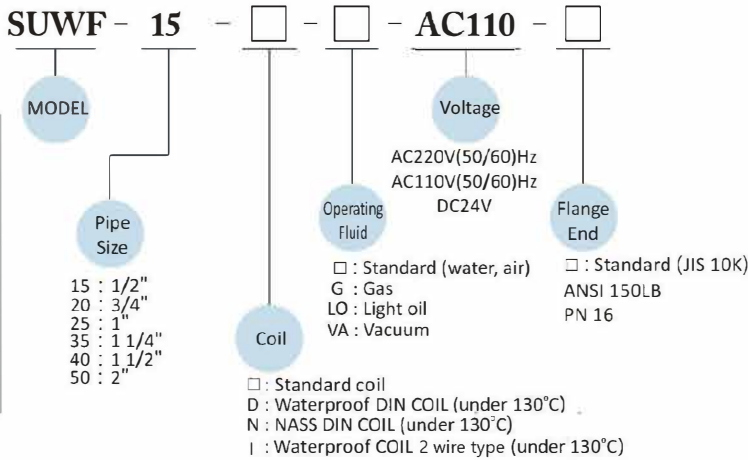

PRODUCT DESCRIPTION

- SUWF series is direct, multiplex, connected diaphragm, conductive and normally closed (NC) 2/2 way solenoid valve.
- Able to be operated directly under low pressure
- Availability of fluid type: water, air, light oil, gas, vacuum
- Acceptable for customization Viton (130°C), Silicone (130°C) and EPDM (130°C, available for SUW-20~25) for plug and diaphragm

CAUTIONS:

- Before pipelining, the pipe line must be very clean without any contaminants or any other things not ought to be existed.
- To prolong the life time of the product, Y-line filter should be installed in the front end of solenoid valve.
- AC voltage tolerance: ± 10%; DC voltage tolerance: ± 1%
- It should be installed horizontally; vertical installation is not advisable.

Not Suitable For Fluid As Below:

- Liquid status when it is high temperature; solid status when it is cool.
- Corrosive fluid
- Viscosity over 20cst

MATERIAL:

PARTS	Coil	Tube	Spring	Core	Plug	Diaphragm	Valve body
MATERIAL	Special copper wire (H class)	Stainless steel	Stainless steel	Stainless steel	NBR	NBR	Stainless steel

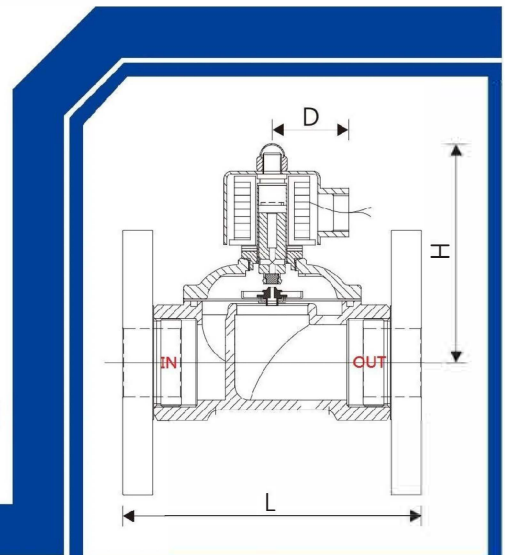

SPECIFICATION

MODEL	Waterproof DIN/flying lead Coil	NASS DIN Coil (IP65)	PIPE SIZE	CV	ORIFICE	FLUID TEMP. (°C)	Operating Pressure kgf / cm ² (bar)			High Pressure Type		vacuum Torr	Dimension (mm)			Weight (kg)
							Water	Air	Light oil	Water	Air		L	H	D	
SUWF-15	●	●	1/2"	4.5	15mm	-5°C ~ +80°C	0~5	0~7	0~5	0.5~10	0.5~20	0~10 ⁻³	100	100	48	2.2
SUWF-20	●	●	3/4"	8.6	20mm	-5°C ~ +80°C	0~5	0~7	0~5	0.5~10	0.5~20	0~10 ⁻³	120	100	48	2.5
SUWF-25	●	●	1"	12	25mm	-5°C ~ +80°C	0~5	0~7	0~5	0.5~10	0.5~20	0~10 ⁻³	150	115	48	4.1
SUWF-35	●	●	1 1/4"	24	35mm	-5°C ~ +80°C	0~5	0~7	0~5	0.5~10	0.5~20	0~10 ⁻³	170	112	48	6.1
SUWF-40	●	●	1 1/2"	28	40mm	-5°C ~ +80°C	0~5	0~7	0~5	0.5~10	0.5~20	0~10 ⁻³	170	112	48	6.7
SUWF-50	●	●	2"	48	50mm	-5°C ~ +80°C	0~5	0~7	0~5	0.5~10	0.5~20	0~10 ⁻³	210	125	48	9.51

● High Pressure Type Use N/O Coil